

TOSHIBA

FILE NO. A06-005

Revised: Jun, 2008

SERVICE MANUAL

AIR-CONDITIONER SPLIT TYPE

<DIGITAL INVERTER>

INDOOR UNIT

RAV-SM402MUT-E

RAV-SM452MUT-E

RAV-SM562MUT-E

This Service Manual describes contents of the new indoor unit.

For the outdoor unit, refer to the Service Manual with **FILE NO. A05-001 and A07-003.**



Adoption of New Refrigerant

This Air Conditioner is a new type which adopts a new refrigerant HFC (R410A) instead of the conventional refrigerant R22 in order to prevent destruction of the ozone layer.

WARNING

Cleaning of the air filter and other parts of the air filter involves dangerous work in high places, so be sure to have a service person do it. Do not attempt it yourself.

The cleaning diagram for the air filter is there for the service person, and not for the customer.

CONTENTS

1. SPECIFICATIONS	4
1-1. Indoor Unit.....	4
1-2. Outdoor Unit.....	9
1-3. Operation Characteristic Curve.....	11
1-4. Capacity Variation Ratio According to Temperature	13
2. CONSTRUCTION VIEWS (EXTERNAL VIEWS)	14
2-1. Indoor Unit.....	14
3. SYSTEMATIC REFRIGERATING CYCLE DIAGRAM	17
3-1. Indoor Unit.....	17
3-2. Outdoor Unit.....	18
4. WIRING DIAGRAM	21
4-1. Indoor Unit.....	21
5. SPECIFICATIONS OF ELECTRICAL PARTS	23
5-1. Indoor Unit.....	23
6. REFRIGERANT R410A	24
6-1. Safety During Installation/Serviceing	24
6-2. Refrigerant Piping Installation.....	24
6-3. Tools	28
6-4. Recharging of Refrigerant.....	29
6-5. Brazing of Pipes.....	30
6-6. Tolerance of Pipe Length and Pipe Head.....	32
6-7. Additional Refrigerant Amount.....	34
6-8. Piping Materials and Sizes.....	36
6-9. Branch Pipe	37
6-10. Distributor	37

7. CONTROL BLOCK DIAGRAM	38
7-1. Indoor Control Circuit	38
7-2. Control Specifications	39
7-3. Indoor Print Circuit Board	46
8. CIRCUIT CONFIGURATION AND CONTROL SPECIFICATIONS.....	47
8-1. Indoor Control Circuit.....	47
9. TROUBLESHOOTING	49
9-1. Summary of Troubleshooting.....	49
9-2. Check Code List.....	51
9-3. Error Mode Detected by LED on Outdoor P.C. Board	54
9-4. Troubleshooting Procedure for Each Check Code.....	55
10. REPLACEMENT OF SERVICE INDOOR P.C. BOARD	71
11. SETUP AT LOCAL SITE AND OTHERS	75
11-1. Indoor Unit.....	75
11-2. Setup at Local Site / Others	82
11-3. How to Set up Central Control Address Number	86
12. ADDRESS SETUP	87
12-1. Address Setup Procedure	87
12-2. Address Setup & Group Control	88
12-3. Address Setup (Manual Setting from Remote Controller).....	91
12-4. Confirmation of Indoor Unit No. Position	92
13. DETACHMENTS	93
13-1. Indoor Unit.....	93
14. EXPLODED VIEWS AND PARTS LIST	101
14-1. Ceiling Panel	101
14-2. Compact 4-way Air Discharge Cassette Type	102

1. SPECIFICATIONS

1-1. Indoor Unit

1-1-1. 4-Way Air Discharge Cassette Type

<Single type>

Model	Indoor unit		RAV-	SM402MUT-E	SM452MUT-E	SM562MUT-E
	Outdoor unit		RAV-	SP404AT(Z, ZG)-E	SP454AT(Z, ZG)-E	SP562AT(Z, ZG)-E
Cooling capacity			(kW)	3.6	4.0	5.0
Heating capacity			(kW)	4.0	4.5	5.6
Power supply			1 phase 230V (220 – 240V) 50Hz			
Electrical characteristics	Cooling	Running current	(A)	5.05 – 4.63	5.82 – 5.33	6.6 – 7.15
		Power consumption	(kW)	1.00	1.19	1.53
		Power factor	(%)	90	93	97
		EER		3.60	3.36	3.27
		Energy efficiency class *		A	A	A
		Energy rating **		5.0	4.5	4.5
	Heating	Running current	(A)	4.79 – 4.39	5.67 – 5.20	6.62 – 7.21
		Power consumption	(kW)	0.97	1.16	1.54
		Power factor	(%)	92	93	97
		COP		4.12	3.88	3.64
		Energy efficiency class *		A	A	A
		Energy rating **		5.5	5.0	4.5
Appearance	Main unit		Zinc hot dipping steel plate			
	Ceiling panel (Sold separately)	Model	RBC-UM11PG (W)-E			
		Panel color	Moon-white (Muncel 2.5GY 9.0/0.5)			
Outer dimension	Main unit	Height	(mm)	268		
		Width	(mm)	575		
		Depth	(mm)	575		
	Ceiling panel (Sold separately)	Height	(mm)	27		
		Width	(mm)	700		
		Depth	(mm)	700		
Total weight	Main unit		(kg)	17		
	Ceiling panel (Sold separately)		(kg)	3		
Heat exchanger			Finned tube			
Fan unit	Fan		Turbo fan			
	Standard air flow	H/M/L	(m ³ /min.)	11.0 / 9.2 / 7.8	13.3 / 11.2 / 9.1	
	Motor		(W)	60		
Air filter			Long life filter			
Controller (Sold separately)			Remote controller			
Connecting pipe	Gas side		(mm)	12.7		
	Liquid side		(mm)	6.4		
	Drain port		(mm)	VP25		
Sound pressure level		H/M/L	(dB•A)	40 / 36 / 31		43 / 39 / 34
Sound power level		H/M/L	(dB•A)	55 / 51 / 46		58 / 54 / 49

* : IEC standard, ** : AS standard

<Single type>

Model	Indoor unit		RAV-	SM562MUT-E	SM562MUT-E
	Outdoor unit		RAV-	SM562AT-E	SM563AT-E
Cooling capacity			(kW)	5.0	5.0
Heating capacity			(kW)	5.6	5.6
Power supply				1 phase 230V (220 – 240V) 50Hz	
Electrical characteristics	Cooling	Running current	(A)	7.02 – 7.75	7.02 – 7.75
		Power consumption	(kW)	1.61	1.61
		Power factor	(%)	95	95
		EER		3.11	3.11
		Energy efficiency class *		B	B
		Energy rating **		4.0	4.0
	Heating	Running current	(A)	7.04 – 7.72	7.04 – 7.72
		Power consumption	(kW)	1.61	1.61
		Power factor	(%)	95	95
		COP		3.48	3.48
		Energy efficiency class *		B	B
		Energy rating **		4.5	4.5
Appearance	Main unit		Zinc hot dipping steel plate		
	Ceiling panel (Sold separately)	Model	RBC-UM11PG (W)-E		
		Panel color	Moon-white (Muncel 2.5GY 9.0/0.5)		
Outer dimension	Main unit	Height	(mm)	268	
		Width	(mm)	575	
		Depth	(mm)	575	
	Ceiling panel (Sold separately)	Height	(mm)	27	
		Width	(mm)	700	
		Depth	(mm)	700	
Total weight	Main unit		(kg)	17	
	Ceiling panel (Sold separately)		(kg)	3	
Heat exchanger				Finned tube	
Fan unit	Fan		Turbo fan		
	Standard air flow	H/M/L	(m³/min.)	13.3 / 11.2 / 9.1	
	Motor		(W)	60	
Air filter				Long life filter	
Controller (Sold separately)				Remote controller	
Sound pressure level		H/M/L	(dB•A)	12.7	
Sound power level		H/M/L	(dB•A)	6.4	
Connecting pipe	Gas side		(mm)	VP25	
	Liquid side		(mm)	43 / 39 / 34	
	Drain port		(mm)	58 / 54 / 49	

* : IEC standard, ** : AS standard

<Twin type>

Model	Indoor unit 1		RAV-	SM562MUT-E	SM562MUT-E	
	Indoor unit 2		RAV-	SM562MUT-E	SM562MUT-E	
	Outdoor unit		RAV-	SP1102AT(Z, ZG)-E	SP1104AT(Z, ZG)-E	
Cooling capacity			(kW)	10.0	10.0	
Heating capacity			(kW)	11.2	11.2	
Indoor unit						
Power supply			1 phase 230V (220 – 240V) 50Hz			
Electrical characteristics	Cooling	Running current (A)		10.31 – 11.24	12.51 – 11.47	
		Power consumption (kW)		2.4	2.67	
		Power factor (%)		97	97	
		EER		4.17	3.75	
		Energy efficiency class *		A	A	
		Energy rating **		—	—	
	Heating	Running current (A)		10.95 – 11.95	12.51 – 11.47	
		Power consumption (kW)		2.55	2.67	
		Power factor (%)		97	97	
		COP		4.39	4.19	
		Energy efficiency class *		A	A	
		Energy rating **		—	—	
Fan unit	Fan		Turbo fan			
	Standard air flow	H/M/L	(m ³ /min.) 13.3 / 11.2 / 9.1			
	Motor		(W) 60			
Sound pressure level		H/M/L	(dB•A) 43 / 39 / 34			
Sound power level		H/M/L	(dB•A) 58 / 54 / 49			
Outdoor unit						
Power supply			1 phase 230V (220 – 240V) 50Hz			
Outer dimension	Standard length		(m) 7.5			
	Min. length		(m) 5 3			
	Max. total length		(m) 50			
	Height difference	Outdoor lower		(m) 30		
		Outdoor higher		(m) 30		
Fan unit	Fan		Propeller fan			
	Standard air flow volume		(m ³ /min.) 125 101			
	Motor		(W) 63 + 63 100 + 100			
Connecting pipe	Gas side	Main		(mm) 15.9		
		Sub		(mm) 12.7		
	Liquid side	Main		(mm) 9.5		
		Sub		(mm) 6.4		
Sound pressure level		Cooling/Heating	(dB•A) 49 / 51 49 / 50			
Sound power level		Cooling/Heating	(dB•A) 66 / 68 66 / 67			

* : EC standard, ** : AS standard

<Twin type>

Model	Indoor unit 1		RAV-	SM562MUT-E	SM562MUT-E	
	Indoor unit 2		RAV-	SM562MUT-E	SM562MUT-E	
	Outdoor unit		RAV-	SM1102AT-E	SM1103AT-E	
Cooling capacity			(kW)	10.0	10.0	
Heating capacity			(kW)	11.2	11.2	
Indoor unit						
Power supply			1 phase 230V (220 – 240V) 50Hz			
Electrical characteristics	Cooling	Running current (A)		14.96 – 16.32	14.96 – 16.32	
		Power consumption (kW)		3.52	3.52	
		Power factor (%)		98	98	
		EER		2.84	2.84	
		Energy efficiency class *		C	C	
		Energy rating **		—	—	
	Heating	Running current (A)		13.35 – 14.56	13.35 – 14.56	
		Power consumption (kW)		3.14	3.14	
		Power factor (%)		98	98	
		COP		3.57	3.57	
		Energy efficiency class *		B	B	
		Energy rating **		—	—	
Fan unit	Fan		Turbo fan			
	Standard air flow	H/M/L	(m ³ /min.) 13.3 / 11.2 / 9.1			
	Motor		(W) 60			
Sound pressure level		H/M/L	(dB•A) 43 / 39 / 34			
Sound power level		H/M/L	(dB•A) 58 / 54 / 49			
Outdoor unit						
Power supply			1 phase 230V (220 – 240V) 50Hz			
Outer dimension	Standard length		(m) 7.5			
	Min. length		(m) 5.0			
	Max. total length		(m) 50			
	Height difference	Outdoor lower		(m) 30		
		Outdoor higher		(m) 30		
Fan unit	Fan		Propeller fan			
	Standard air flow volume		(m ³ /min.) 75			
	Motor		(W) 100		63	
Connecting pipe	Gas side	Main		(mm) 15.9		
		Sub		(mm) 12.7		
	Liquid side	Main		(mm) 9.5		
		Sub		(mm) 6.4		
Sound pressure level		Cooling/Heating	(dB•A) 53 / 54			
Sound power level		Cooling/Heating	(dB•A) 70 / 71			

* : IEC standard, ** : AS standard

<Triple type>

Model	Indoor unit 1		RAV-SM562MUT-E
	Indoor unit 2		RAV-SM562MUT-E
	Indoor unit 3		RAV-SM562MUT-E
	Outdoor unit		RAV-SM1603AT-E
Cooling capacity		(kW)	14.0
Heating capacity		(kW)	16.0
Indoor unit			
Power supply		1 phase 230V (220 – 240V) 50Hz	
Electrical characteristics	Cooling	Running current	(A) 23.88 – 21.89
		Power consumption	(kW) 4.99
		Power factor	(%) 95
		EER	2.81
		Energy efficiency class *	C
	Heating	Running current	(A) 22.44 – 20.57
		Power consumption	(kW) 4.69
		Power factor	(%) 95
		COP	3.41
		Energy efficiency class *	B
Fan unit	Fan		Turbo fan
	Standard air flow	H/M/L (m ³ /min.)	13.3 / 11.2 / 9.1
	Motor		(W) 60
Sound pressure level		H/M/L (dB•A)	43 / 39 / 34
Sound power level		H/M/L (dB•A)	58 / 54 / 49
Outdoor unit			
Power supply		1 phase 230V (220 – 240V) 50Hz	
Outer dimension	Standard length		(m) 7.5
	Min. length		(m) 5.0
	Max. total length		(m) 50
	Height difference	Outdoor lower	(m) 30
		Outdoor higher	(m) 30
Fan unit	Fan		Propeller fan
	Standard air flow volume		(m ³ /min.) 103
	Motor		(W) 100 + 100
Connecting pipe	Gas side	Main	(mm) 15.9
		Sub	(mm) 12.7
	Liquid side	Main	(mm) 9.5
		Sub	(mm) 6.4
Sound pressure level		Cooling/Heating (dB•A)	51 / 53
Sound power level		Cooling/Heating (dB•A)	68 / 70

* : IEC standard

1-2. Outdoor Unit

<Super Digital Inverter>

Model name	Outdoor unit	RAV-SP	562AT(Z)(ZG)-E	802AT(Z)(ZG)-E	1104AT(Z)(ZG)-E	1404AT(Z)(ZG)-E	
Power supply		1 phase 230V (220 – 240V) 50Hz (Power exclusive to outdoor is required.)					
Compressor	Type	Hermetic compressor					
	Motor	(kW)	2	2	3.75	3.75	
	Pole		4	4	4	4	
Refrigerant charged		(kg)	1.5	2.1	3.1	3.1	
Refrigerant control		Pulse motor valve					
Inter connecting pipe	Standard length		(m)	7.5	7.5	7.5	7.5
	Max. total length		(m)	50	50	75	75
	Additional refrigerant charge under long piping connector			20g/m (21m to 50m)	40g/m (31m to 50m)	40g/m (31m to 75m)	40g/m (31m to 75m)
	Height difference	Outdoor lower	(m)	30	30	30	30
		Outdoor higher	(m)	30	30	30	30
Outer dimension	Height		(mm)	795	795	1340	1340
	Width		(mm)	900	900	900	900
	Depth		(mm)	320	320	320	320
Appearance		Silky shade (Muncel 1Y8.5/0.5)					
Total weight		(kg)	55	62	93	93	
Heat exchanger		Finned tube					
Fan unit	Fan		Propeller fan				
	Standard air flow		(m³/h)	57	57	101	103
	Motor		(W)	63	63	100 + 100	100 + 100
Connecting pipe	Gas side		(mm)	12.7	15.9	15.9	15.9
	Liquid side		(mm)	6.4	9.5	9.5	9.5
Sound pressure level		Cooling/Heating	(dB•A)	46 / 47	47 / 49	49 / 50	51 / 52
Sound power level		Cooling/Heating	(dB•A)	63 / 64	64 / 66	66 / 67	68 / 69
Outside air temperature, Cooling		(°C)	43 to –15°C				
Outside air temperature, Heating		(°C)	15 to –15°C		15 to –20°C		

Model name	Outdoor unit	RAV-SP404AT(Z)(ZG)-E	RAV-SP454AT(Z)(ZG)-E	
Power supply		1 phase 230V (220 – 240V) 50Hz (Power exclusive to outdoor is required.)		
Compressor	Type	Hermetic compressor		
	Motor (kW)	1.1	1.1	
	Pole	4	4	
Refrigerant charged (kg)		1.0	1.0	
Refrigerant control		Pulse motor valve		
Inter connecting pipe	Standard length (m)	7.5	7.5	
	Max. total length (m)	30	30	
	Additional refrigerant charge under long piping connector		20g/m (21m to 30m)	
	Height difference	Outdoor lower (m)	30	30
		Outdoor higher (m)	30	30
Outer dimension	Height (mm)	550	550	
	Width (mm)	780	780	
	Depth (mm)	290	290	
Appearance		Silky shade (Muncel 1Y8.5/0.5)		
Total weight (kg)		40	40	
Heat exchanger		Finned tube		
Fan unit	Fan	Propeller fan		
	Standard air flow (m ³ /h)	40	40	
	Motor (W)	43	43	
Connecting pipe	Gas side (mm)	12.7	12.7	
	Liquid side (mm)	6.4	6.4	
Sound pressure level	Cooling/Heating (dB•A)	45 / 47	45 / 47	
Sound power level	Cooling/Heating (dB•A)	62 / 64	62 / 64	
Outside air temperature, Cooling (°C)		43 to –15°C		
Outside air temperature, Heating (°C)		15 to –15°C		

1-3. Operation Characteristic Curve

<Digital Inverter>

RAV-SM562MUT-E / RAV-SM562AT-E

<Cooling>

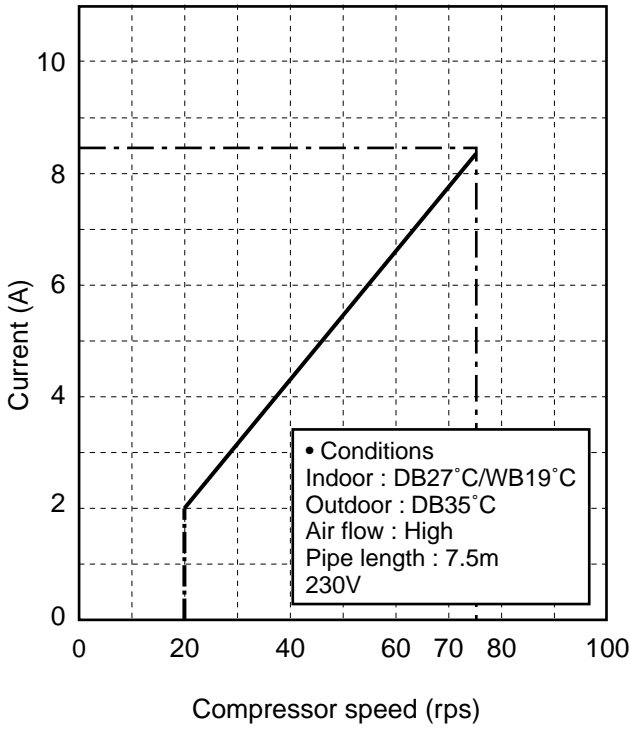

<Heating>

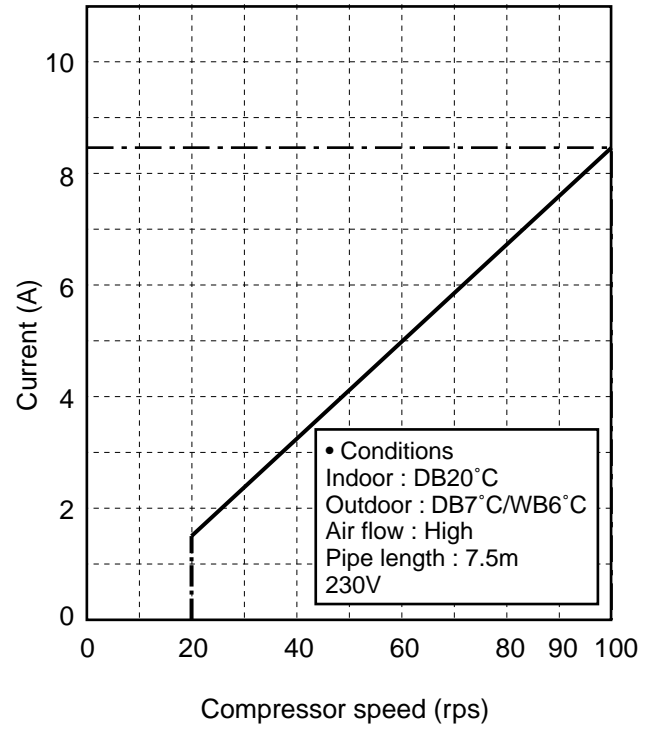

<Super Digital Inverter>

RAV-SM562MUT-E / RAV-SP562AT-E

<Cooling>

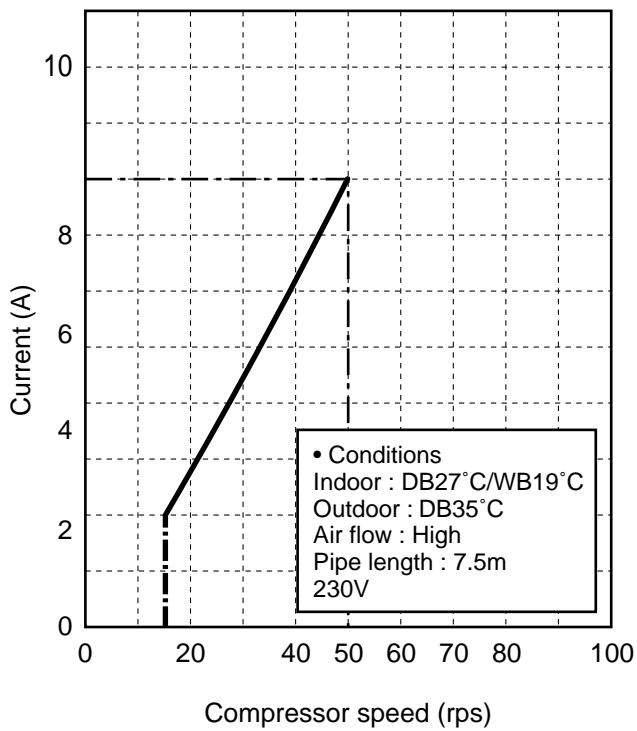

<Heating>

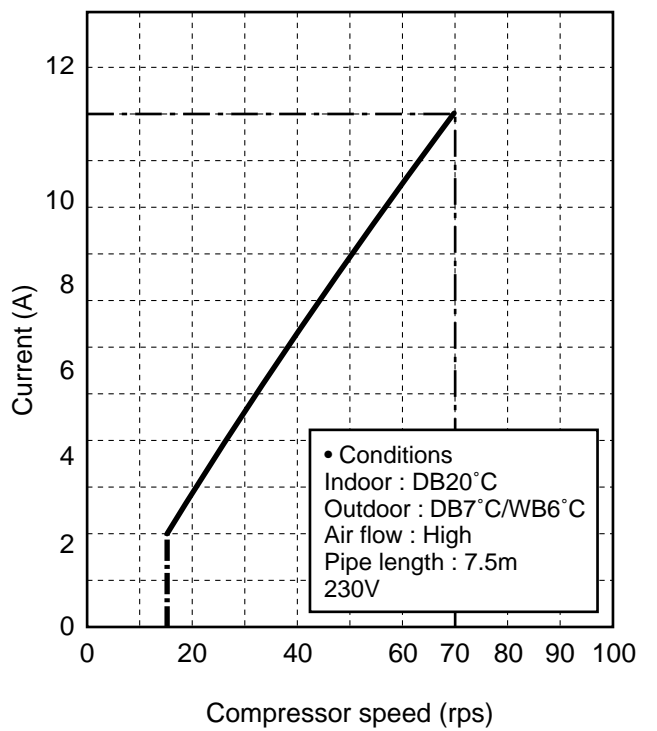

<Super Digital Inverter>

RAV-SP404AT-E, RAV-SP404ATZ-E, RAV-SP404ATZG-E
 RAV-SP454AT-E, RAV-SP454ATZ-E, RAV-SP454ATZG-E

<Cooling>

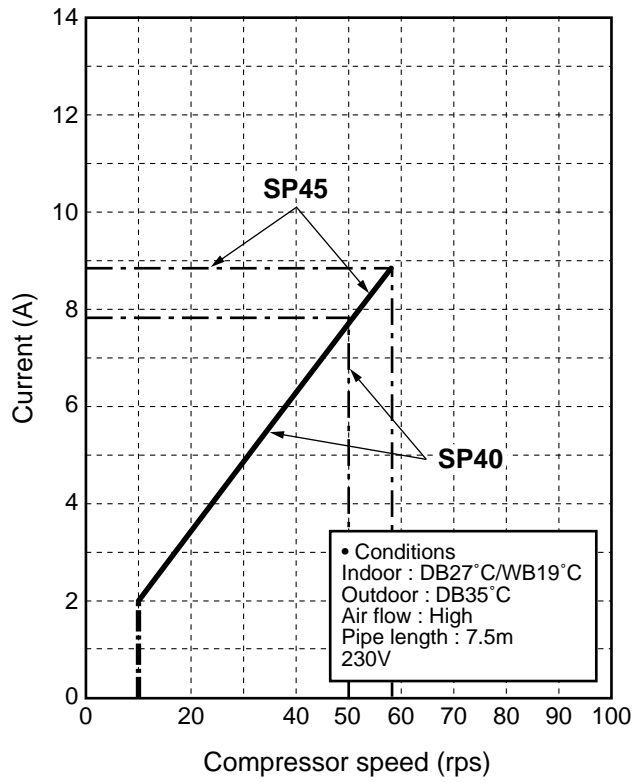

<Heating>

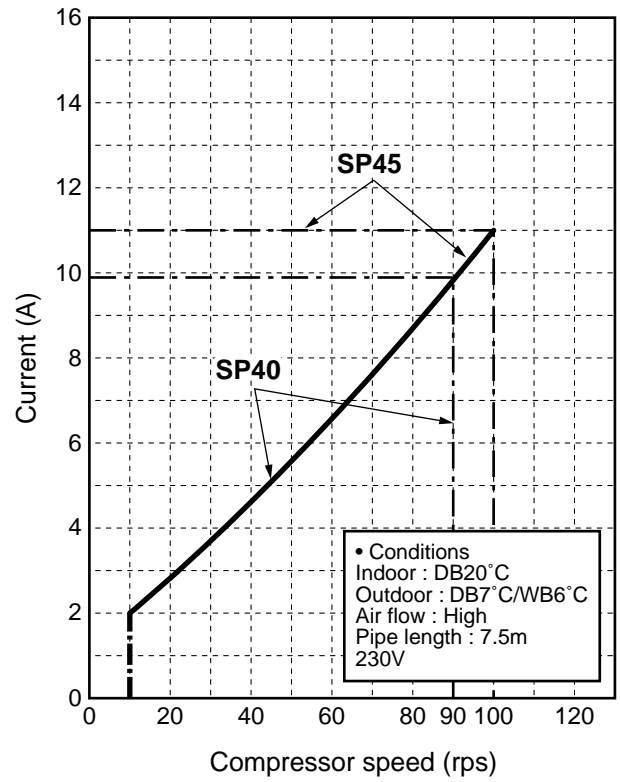

1-4. Capacity Variation Ratio According to Temperature

RAV-SP404AT-E, RAV-SP404ATZ-E, RAV-SP404ATZG-E

RAV-SP454AT-E, RAV-SP454ATZ-E, RAV-SP454ATZG-E

<Cooling>

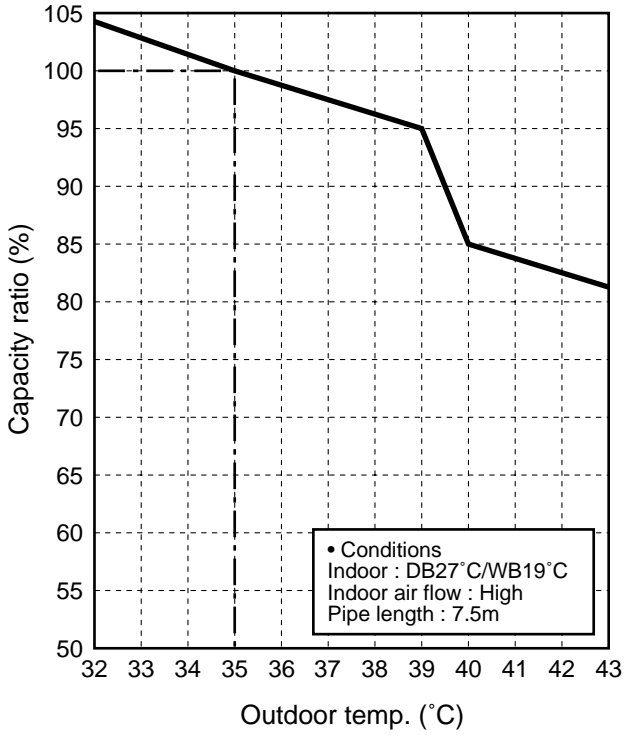

<Heating>

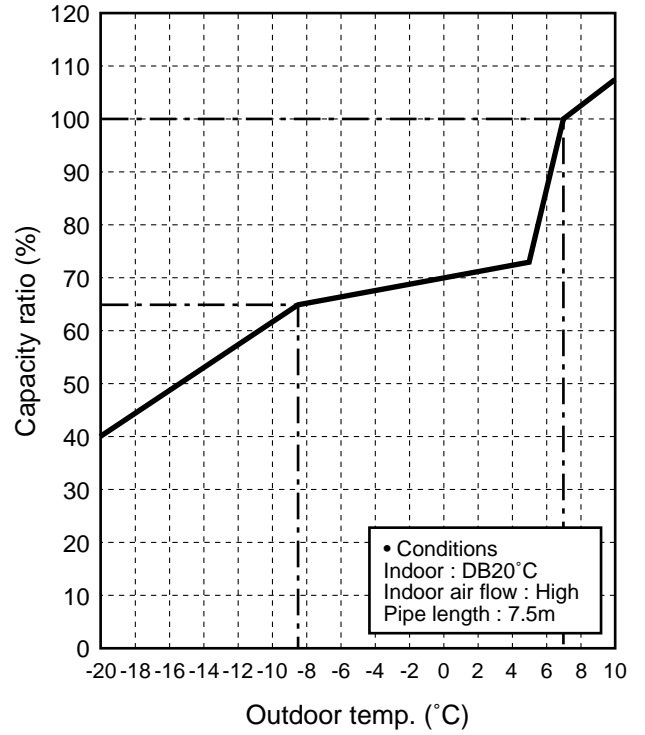

RAV-SP562AT-E, RAV-SM563AT-E

<Cooling>

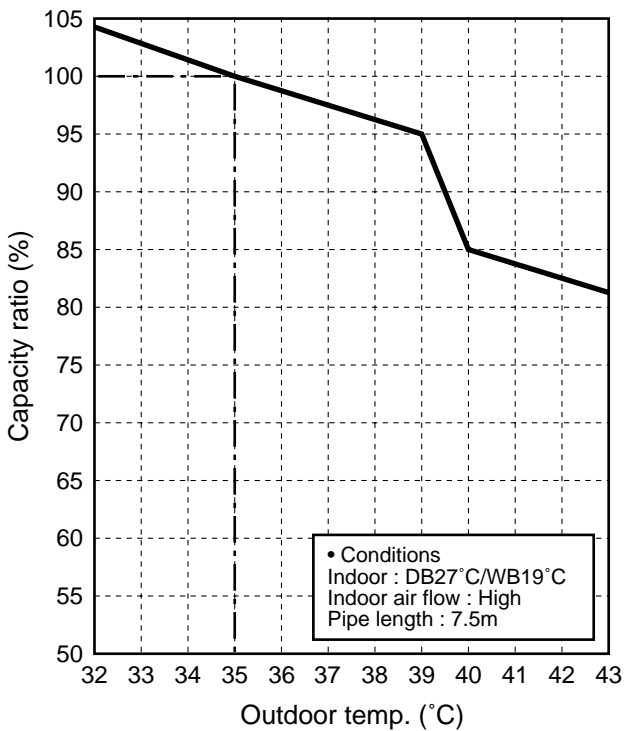

<Heating>

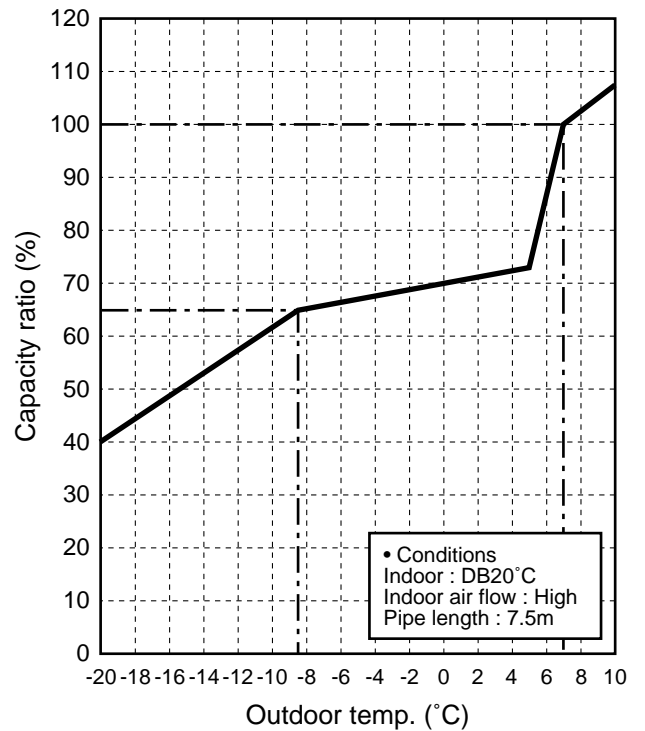

2. CONSTRUCTION VIEWS (EXTERNAL VIEWS)

2-1. Indoor Unit

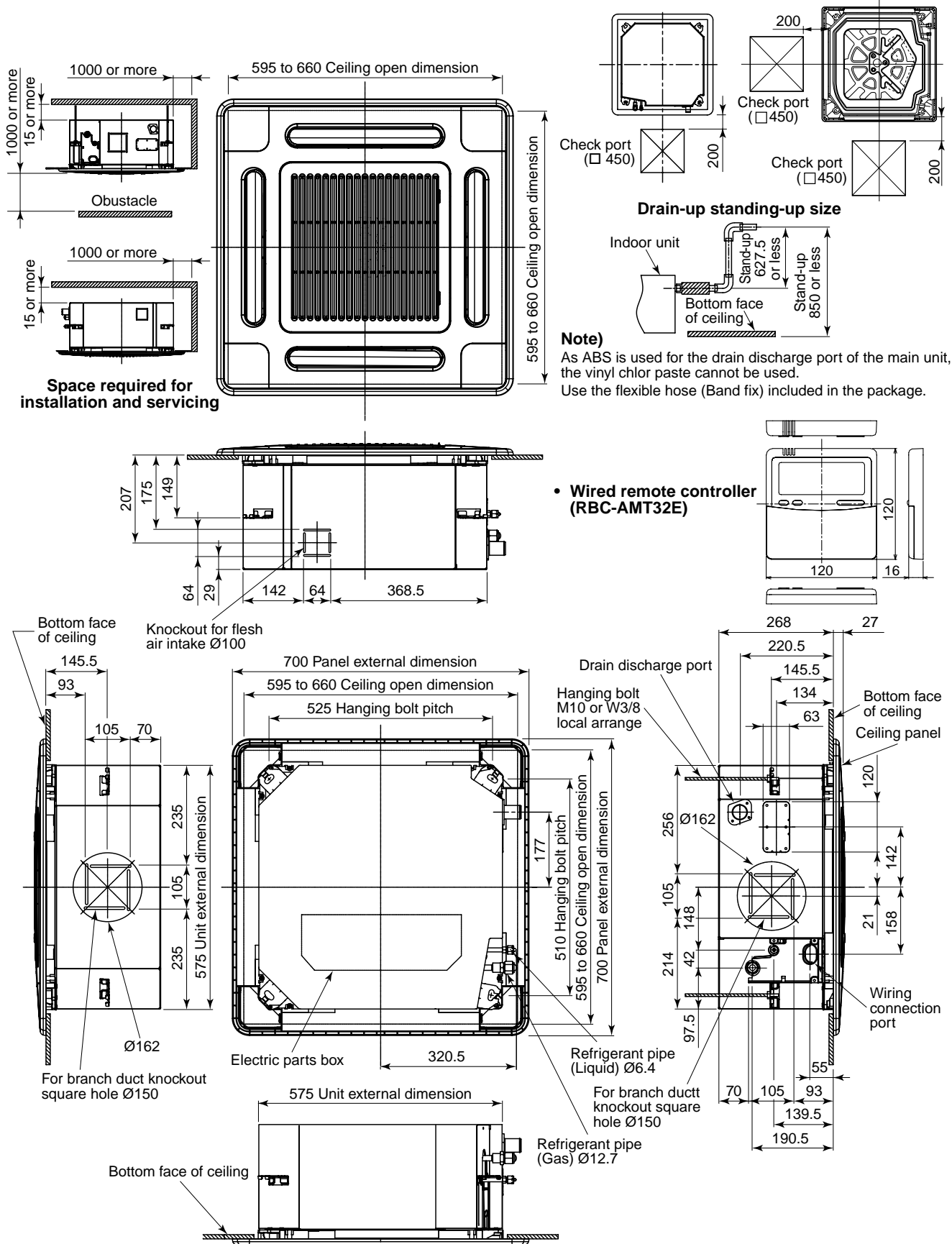

RBC-TWP30E2, RBC-TWP50E2 (Simultaneous Twin)

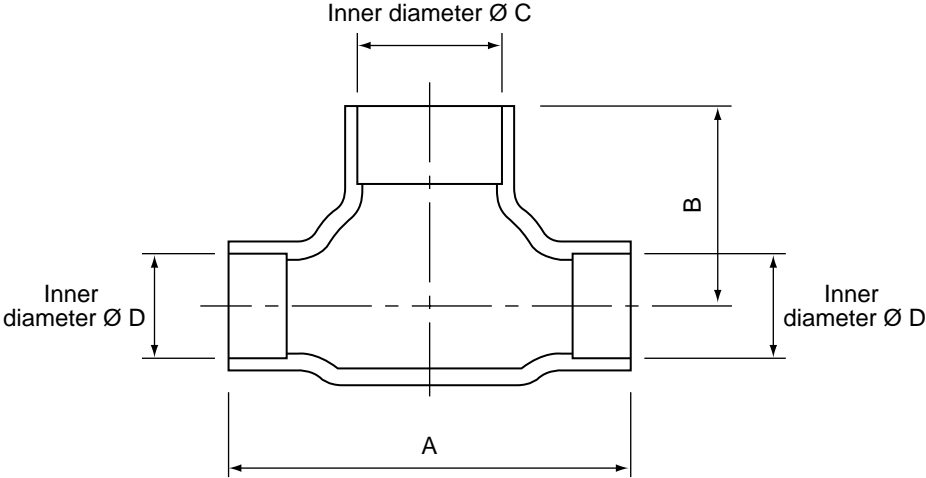

Model (RBC-)		A	B	C	D
TWP30E2	Liquid side	36	14	Ø9.5	Ø6.4
	Gas side	43	23	Ø15.9	Ø12.7
TWP50E2	Liquid side	34	14	Ø9.5	Ø9.5
	Gas side	44	21	Ø15.9	Ø15.9

RBC-TRP100E (Simultaneous Triple)

<Gas side>

Header assembly

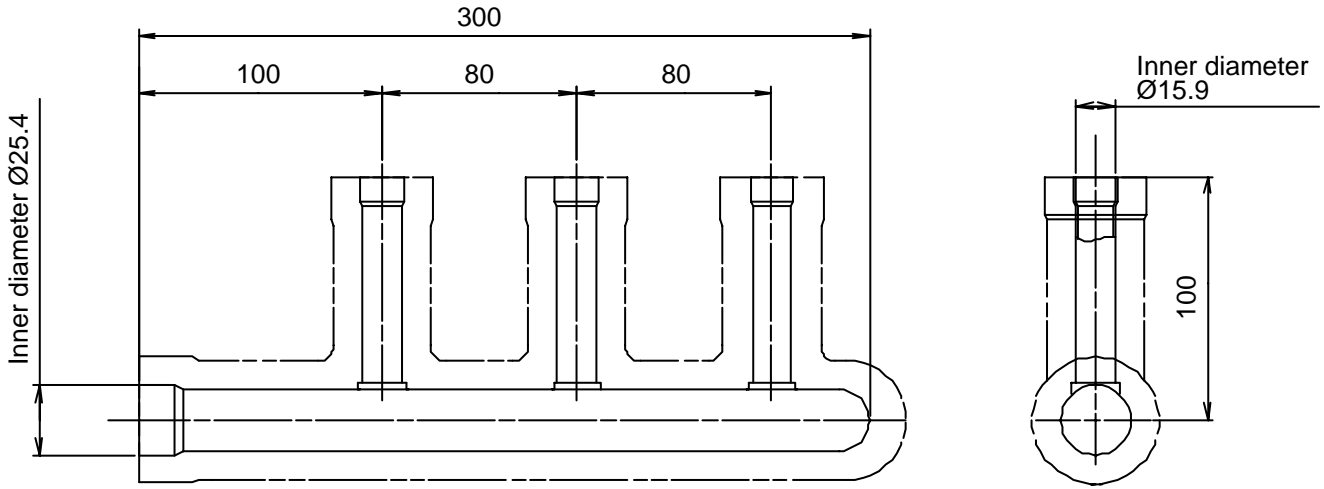

<Liquid side>

Branch pipe assembly

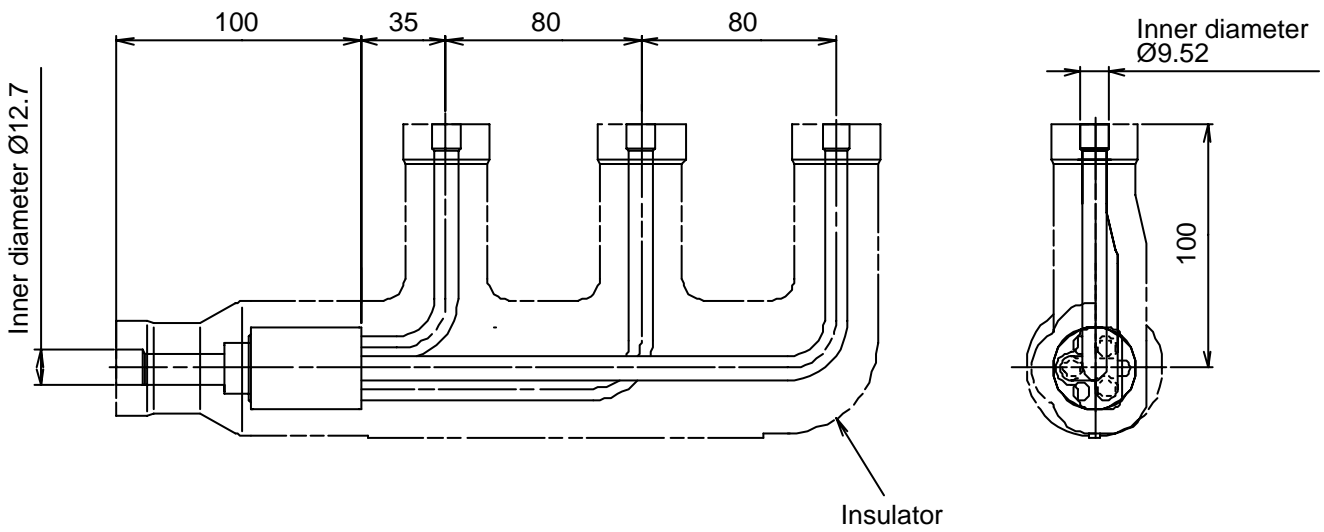

Gas side socket

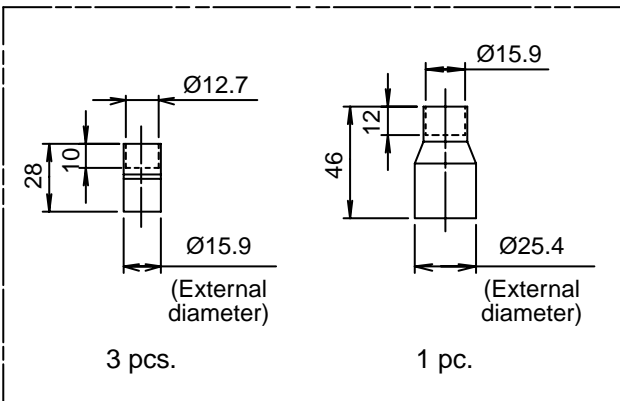

Liquid side socket

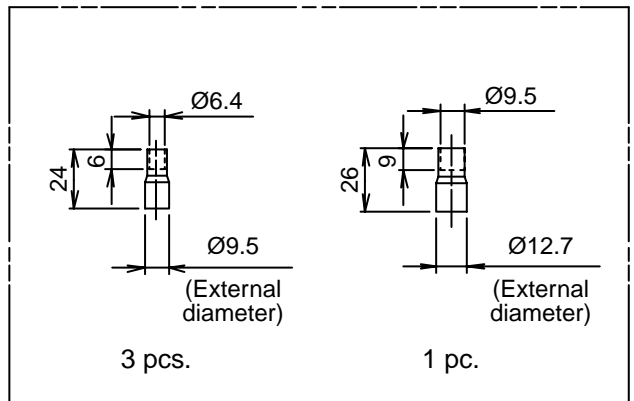

3. SYSTEMATIC REFRIGERATING CYCLE DIAGRAM

3-1. Indoor Unit

- **Single type**
(Combination of one indoor unit and one outdoor unit)

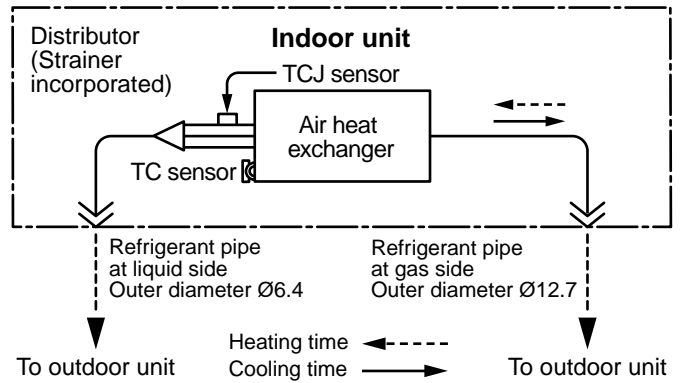

- **Twin type** (Combination of two indoor units and one outdoor unit)

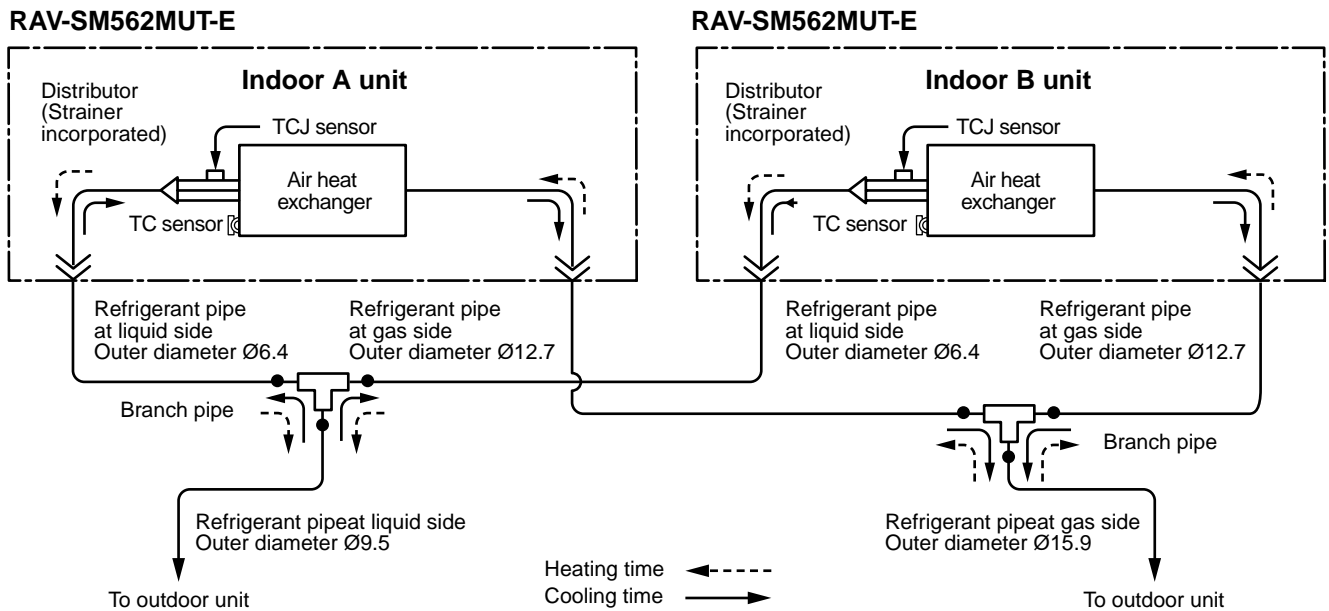

- **Triple type** (Combination of three indoor units and one outdoor unit)

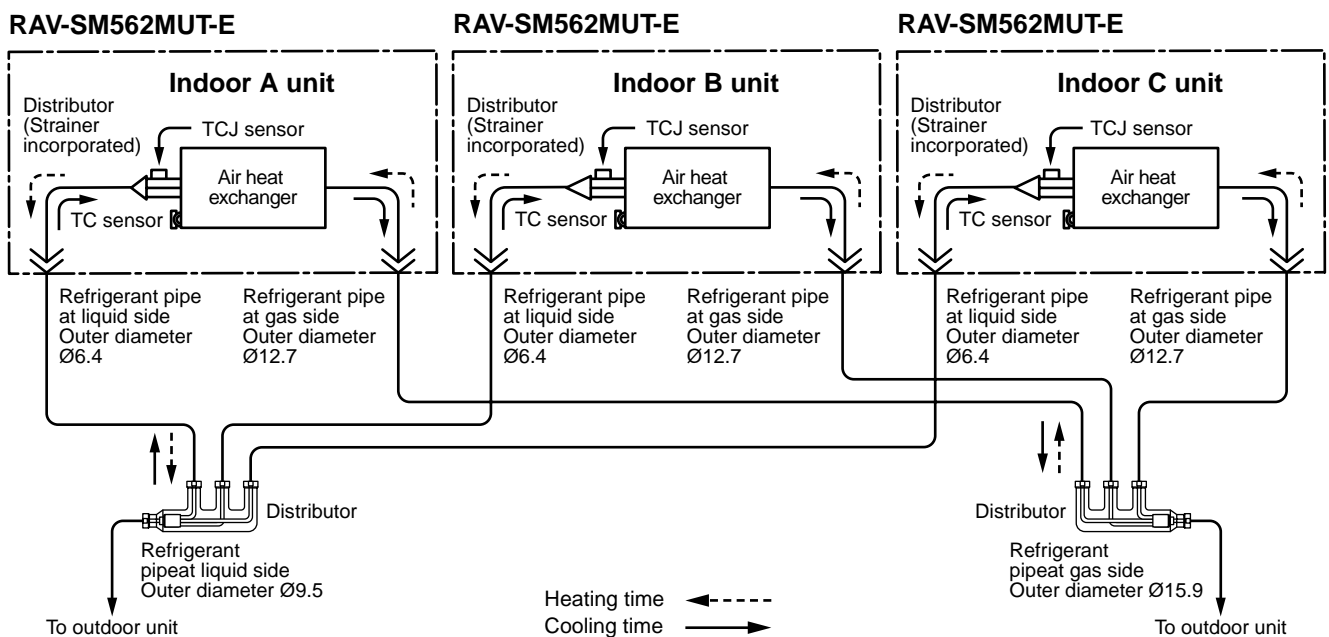

3-2. Outdoor Unit

RAV-SM562MUT-E / RAV-SP562AT-E

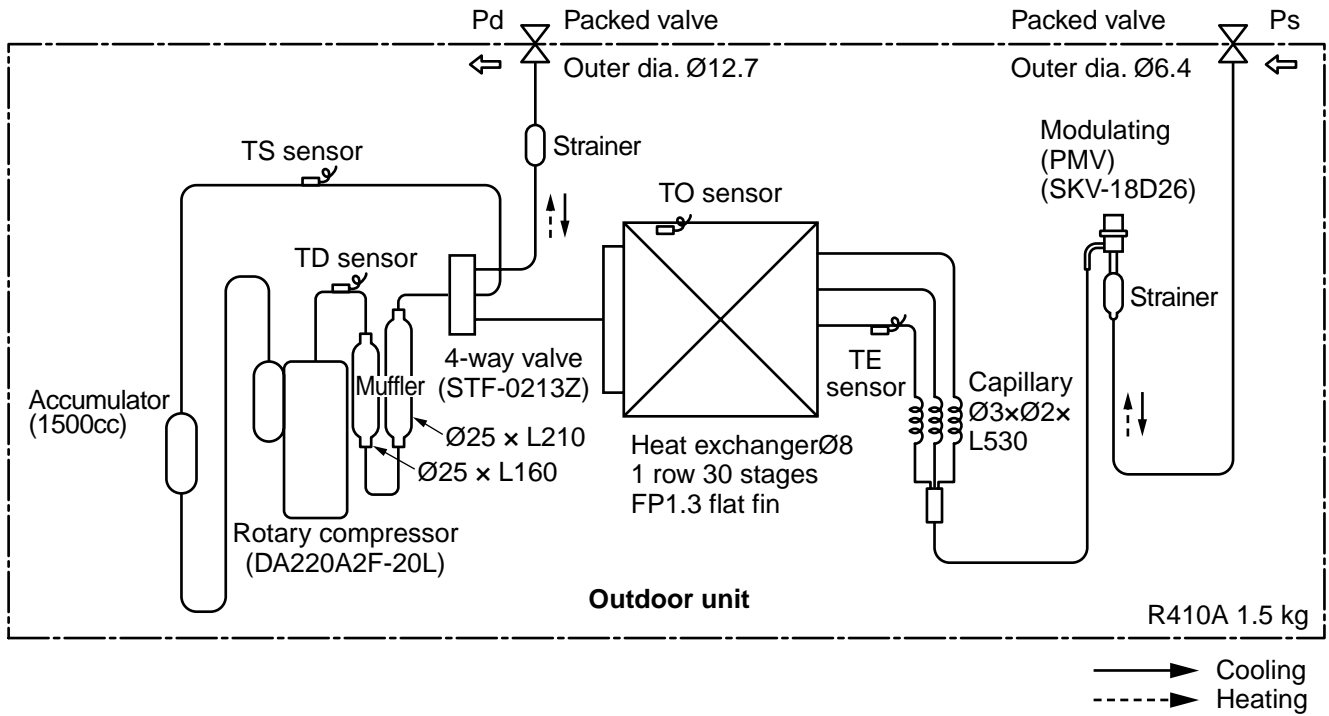

		Pressure (MPa)		Pipe surface temperature (°C)				Compressor revolutions per second (rps) *	Indoor fan	Indoor/Outdoor temp. conditions (DB/WB) (°C)	
				Discharge	Suction	Indoor heat exchanger	Outdoor heat exchanger			Indoor	Outdoor
		Pd	Ps	(TD)	(TS)	(TC)	(TE)				
Cooling	Standard	2.71	1.03	75	15	10	38	43	HIGH	27/19	35/-
	Overload	3.48	1.16	81	20	16	51	44	HIGH	32/24	43/-
	Low load	1.92	0.74	34	5	2	11	24	LOW	18/15.5	-5/-
Heating	Standard	2.22	0.72	62	6	38	2	41	HIGH	20/-	7/6
	Overload	3.47	1.16	81	20	55	15	41	LOW	30/-	24/18
	Low load	1.79	0.25	71	-16	30	-18	70	HIGH	15/-	-20/(70%)

* This compressor has 4-pole motor. The value when compressor frequency (Hz) is measured by a clamp meter becomes 2 times of No. of compressor revolutions (rps).

RAV-SM562MUT-E / RAV-SM562AT-E

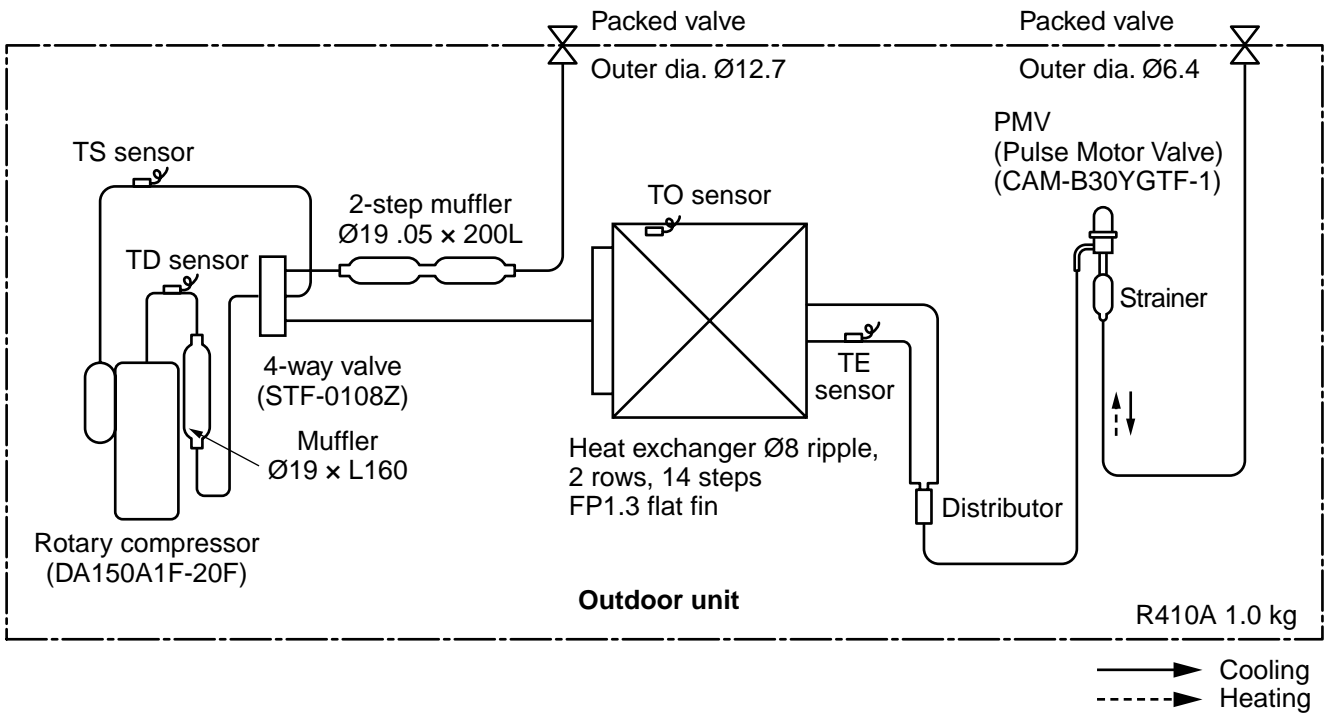

		Pressure				Pipe surface temperature (°C)				Compressor revolutions per second (rps) *	Indoor fan	Indoor/Outdoor temp. conditions (DB/WB) (°C)	
		(MPa)		(kg/cm ² G)		Discharge	Suction	Indoor heat exchanger	Outdoor heat exchanger			Indoor	Outdoor
		Pd	Ps	Pd	Ps	(TD)	(TS)	(TC)	(TE)				
Cooling	Standard	3.50	0.97	35.7	9.9	85	14	12	48	70	HIGH	27/19	35/-
	Overload	3.90	1.08	39.8	11.0	93	26	17	54	70	HIGH	32/24	43/-
	Low load	1.90	0.70	19.4	7.1	48	7	5	30	50	LOW	18/15.5	-5/-
Heating	Standard	2.31	0.61	13.6	6.2	87	5	40	1	97	HIGH	20/-	7/6
	Overload	2.86	0.89	29.2	9.1	86	17	47	11	95	LOW	28/-	24/18
	Low load	1.86	0.25	19.0	2.6	69	-14	31	-15	98	HIGH	15/-	-10/(70%)

* This compressor has 4-pole motor. The value when compressor frequency (Hz) is measured by a clamp meter becomes 2 times of No. of compressor revolutions (rps).

RAV-SM402MUT-E / RAV-SP404AT-E
RAV-SM454MUT-E / RAV-SP454AT-E

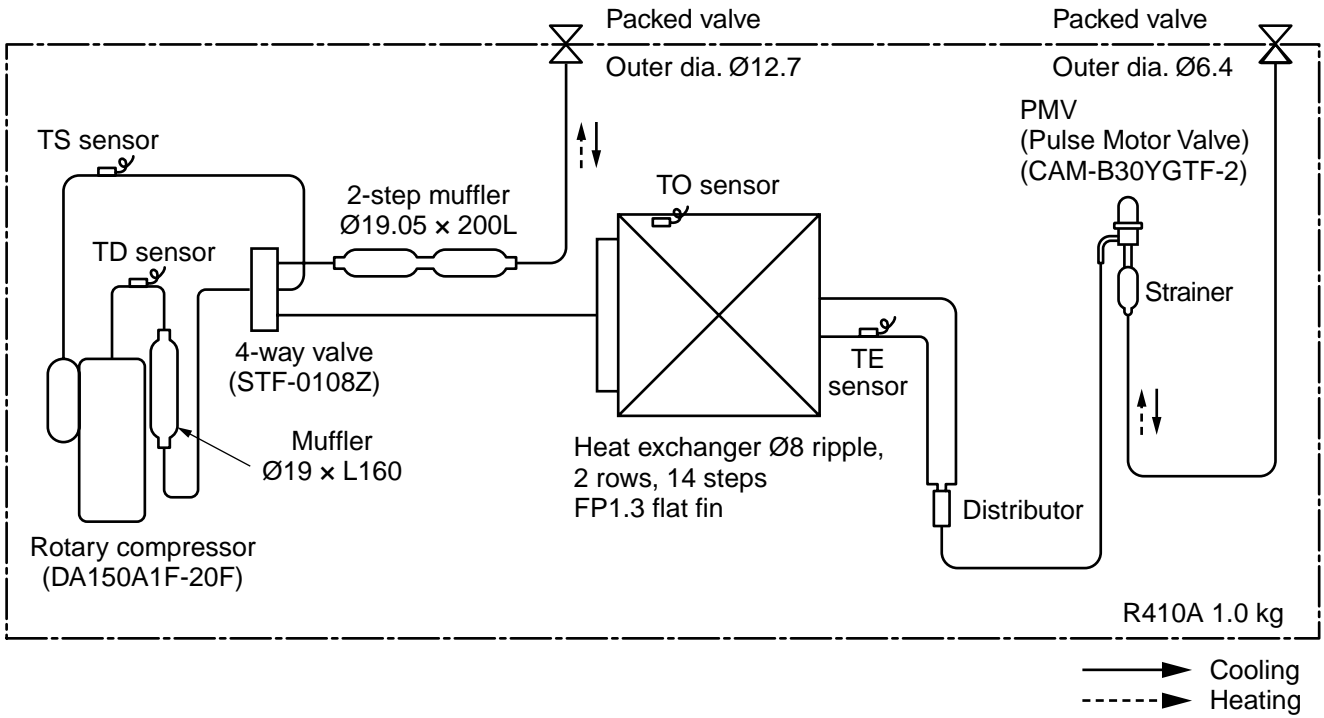

RAV-SP404AT-E

		Pressure				Pipe surface temperature (°C)				Compressor drive revolution frequency (rps)	Indoor fan	Indoor/Outdoor temp. conditions (DB/WB) (°C)	
		(MPa)		(kg/cm ² g)		Discharge	Suction	Indoor heat exchanger	Outdoor heat exchanger			Indoor	Outdoor
		Pd	Ps	Pd	Ps	(TD)	(TS)	(TC)	(TE)				
Cooling	Standard	2.68	0.94	27.3	9.6	61	12	11	43	47	HIGH	27/19	35/-
	Overload	3.23	1.16	32.9	11.8	77	14	15	50	50	HIGH	32/24	43/-
	Low load	1.34	0.70	13.7	7.1	36	4	2	8	44	LOW	18/15.5	-5/-
Heating	Standard	2.38	0.70	24.3	7.1	65	7	39	4	49	HIGH	20/-	7/6
	Overload	3.39	1.03	34.6	10.5	83	20	54	16	49	LOW	30/-	24/18
	Low load	1.95	0.26	19.9	2.7	90	-17	32	-19	90	HIGH	15/-	-15/-

* This compressor has 4-pole motor. The value when compressor frequency (Hz) is measured by a clamp meter becomes 2 times of No. of compressor revolutions (rps).

RAV-SP454AT-E

		Pressure				Pipe surface temperature (°C)				Compressor drive revolution frequency (rps)	Indoor fan	Indoor/Outdoor temp. conditions (DB/WB) (°C)	
		(MPa)		(kg/cm ² g)		Discharge	Suction	Indoor heat exchanger	Outdoor heat exchanger			Indoor	Outdoor
		Pd	Ps	Pd	Ps	(TD)	(TS)	(TC)	(TE)				
Cooling	Standard	2.81	0.89	28.7	9.1	68	11	10	41	53	HIGH	27/19	35/-
	Overload	3.24	1.16	33.0	11.8	78	14	15	51	53	HIGH	32/24	43/-
	Low load	1.34	0.70	13.7	7.1	36	4	2	8	44	LOW	18/15.5	-5/-
Heating	Standard	2.53	0.68	25.8	6.9	70	7	41	4	56	HIGH	20/-	7/6
	Overload	3.39	1.03	34.6	10.5	83	20	54	16	49	LOW	30/-	24/18
	Low load	2.00	0.25	20.4	2.6	92	-17	33	-19	98	HIGH	15/-	-15/-

* This compressor has 4-pole motor. The value when compressor frequency (Hz) is measured by a clamp meter becomes 2 times of No. of compressor revolutions (rps).

4. WIRING DIAGRAM

4-1. Indoor Unit

4-1-1. Compact 4-way Cassette Type

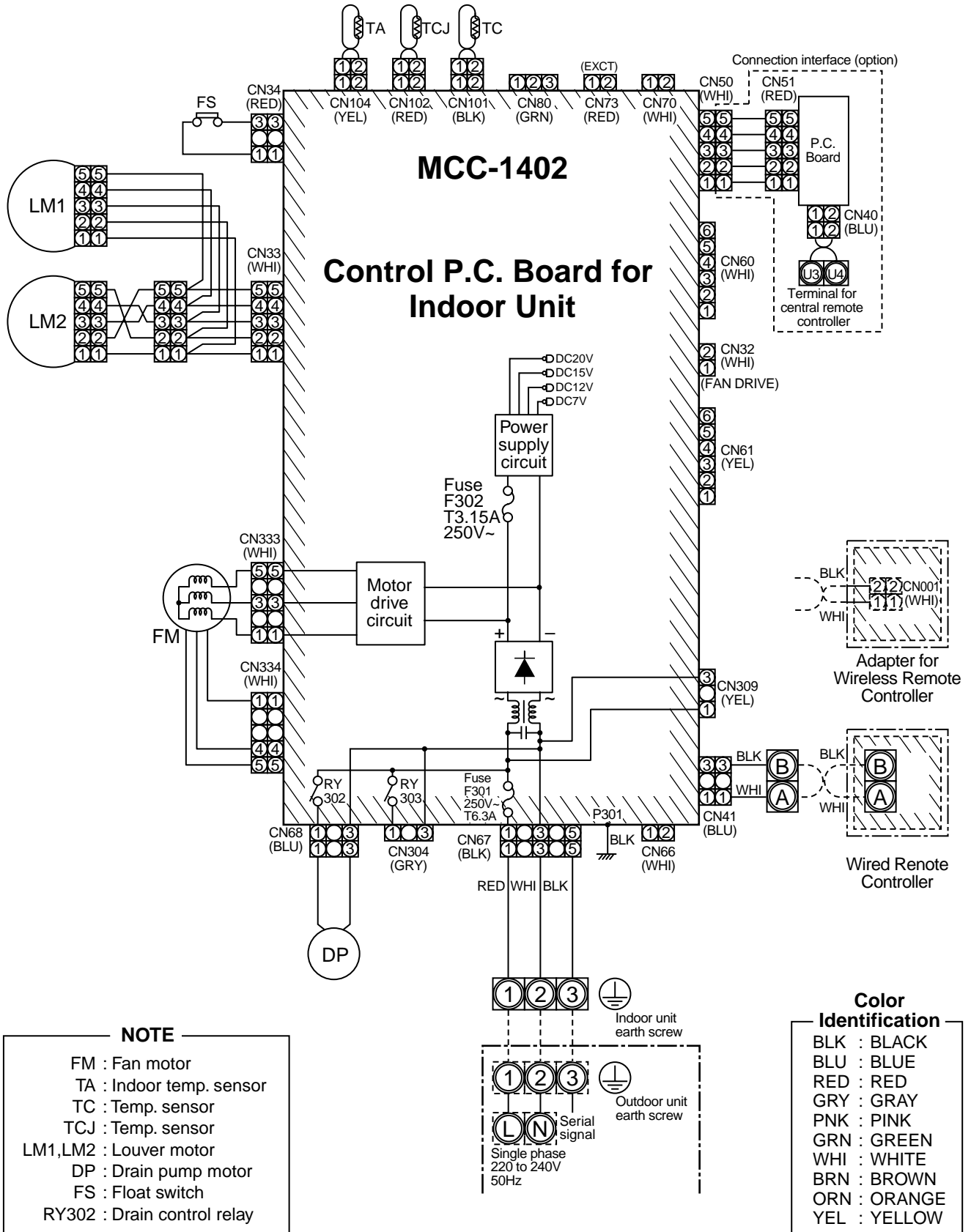

• Single type

Power supply 220-240V
Single phase 50Hz

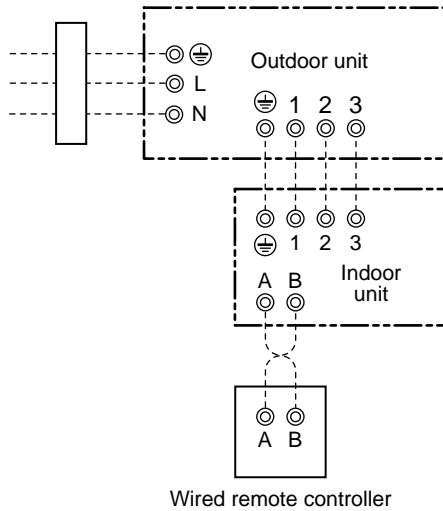

• Twin type

Power supply 220-240V
Single phase 50Hz

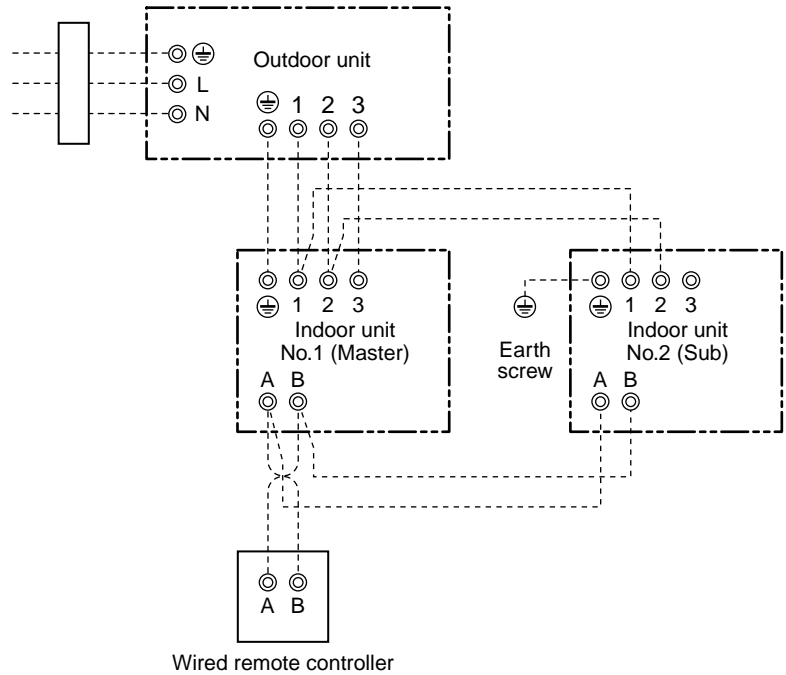

• Triple type

Power supply 220-240V
Single phase 50Hz

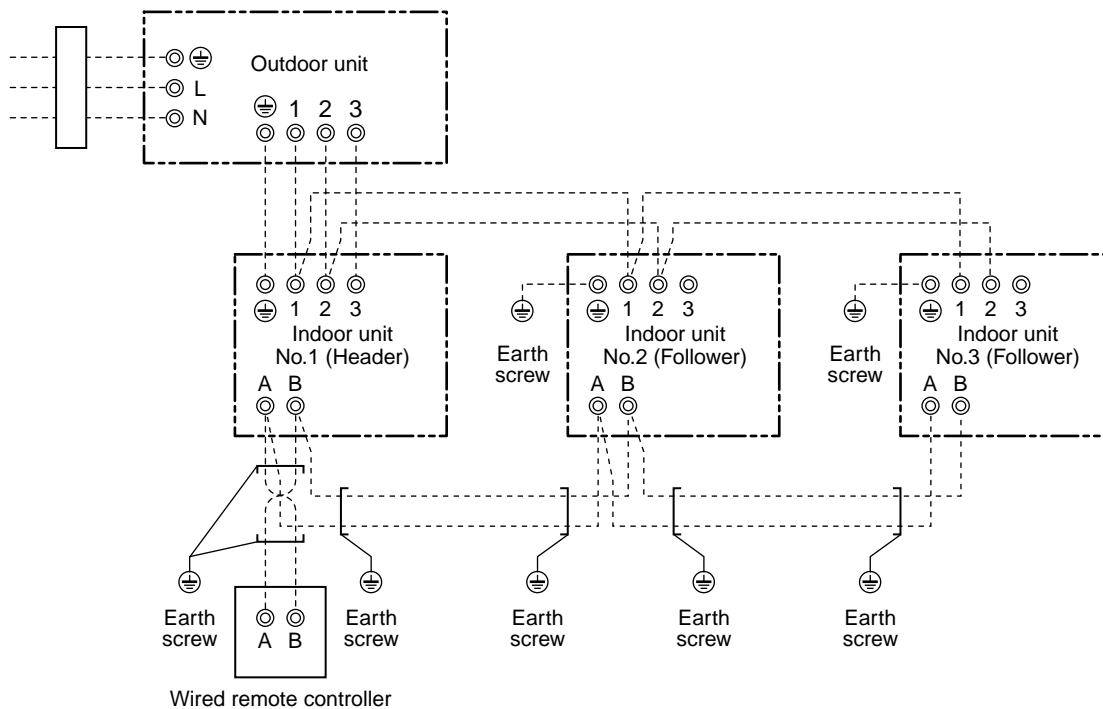

Notes)

1. Ⓞ : indicates a terminal block
2. Broken line and chain line indicate wiring at local site.
3. For the inner wiring diagram of the outdoor unit and the indoor unit, refer to the wiring diagram of each model.
4. There is no polarity. It is no problem that the remote controller is connected to the indoor unit terminal block A and B reversely.
5. When using a wireless remote controller, connection of the remote controller to A and B terminal blocks are unnecessary. (Wire connection between indoor unit No.1 and No.2 is necessary.)

5. SPECIFICATIONS OF ELECTRICAL PARTS

5-1. Indoor Unit

No.	Parts name	Type	Specifications
1	Fan motor (for indoor)	SWF-230-60-1R	Output (Rated) 60 W, 220–240 V
2	Thermo. sensor (TA-sensor)	155 mm	10 k Ω at 25°C
3	Heat exchanger sensor (TCJ-sensor)	Ø6 mm, 1200 mm	10 k Ω at 25°C
4	Heat exchanger sensor (TC-sensor)	Ø6 mm, 1200 mm	10 k Ω at 25°C
5	Float switch	FS-0218-106	
6	Drain pump motor	ADP-1406	

6. REFRIGERANT R410A

This air conditioner adopts the new refrigerant HFC (R410A) which does not damage the ozone layer.

The working pressure of the new refrigerant R410A is 1.6 times higher than conventional refrigerant (R22). The refrigerating oil is also changed in accordance with change of refrigerant, so be careful that water, dust, and existing refrigerant or refrigerating oil are not entered in the refrigerant cycle of the air conditioner using the new refrigerant during installation work or servicing time.

The next section describes the precautions for air conditioner using the new refrigerant. Conforming to contents of the next section together with the general cautions included in this manual, perform the correct and safe work.

6-1. Safety During Installation/Serviceing

As R410A's pressure is about 1.6 times higher than that of R22, improper installation/serviceing may cause a serious trouble. By using tools and materials exclusive for R410A, it is necessary to carry out installation/serviceing safely while taking the following precautions into consideration.

- 1) Never use refrigerant other than R410A in an air conditioner which is designed to operate with R410A.
If other refrigerant than R410A is mixed, pressure in the refrigeration cycle becomes abnormally high, and it may cause personal injury, etc. by a rupture.
- 2) Confirm the used refrigerant name, and use tools and materials exclusive for the refrigerant R410A.
The refrigerant name R410A is indicated on the visible place of the outdoor unit of the air conditioner using R410A as refrigerant. To prevent mischarging, the diameter of the service port differs from that of R22.
- 3) If a refrigeration gas leakage occurs during installation/serviceing, be sure to ventilate fully.
If the refrigerant gas comes into contact with fire, a poisonous gas may occur.
- 4) When installing or removing an air conditioner, do not allow air or moisture to remain in the refrigeration cycle. Otherwise, pressure in the refrigeration cycle may become abnormally high so that a rupture or personal injury may be caused.
- 5) After completion of installation work, check to make sure that there is no refrigeration gas leakage.
If the refrigerant gas leaks into the room, coming into contact with fire in the fan-driven heater, space heater, etc., a poisonous gas may occur.

- 6) When an air conditioning system charged with a large volume of refrigerant is installed in a small room, it is necessary to exercise care so that, even when refrigerant leaks, its concentration does not exceed the marginal level.
If the refrigerant gas leakage occurs and its concentration exceeds the marginal level, an oxygen starvation accident may result.
- 7) Be sure to carry out installation or removal according to the installation manual.
Improper installation may cause refrigeration trouble, water leakage, electric shock, fire, etc.
- 8) Unauthorized modifications to the air conditioner may be dangerous. If a breakdown occurs please call a qualified air conditioner technician or electrician.
Improper repair's may result in water leakage, electric shock and fire, etc.

6-2. Refrigerant Piping Installation

6-2-1. Piping Materials and Joints Used

For the refrigerant piping installation, copper pipes and joints are mainly used. Copper pipes and joints suitable for the refrigerant must be chosen and installed. Furthermore, it is necessary to use clean copper pipes and joints whose interior surfaces are less affected by contaminants.

- 1) Copper Pipes
It is necessary to use seamless copper pipes which are made of either copper or copper alloy and it is desirable that the amount of residual oil is less than 40 mg/10 m. Do not use copper pipes having a collapsed, deformed or discolored portion (especially on the interior surface). Otherwise, the expansion valve or capillary tube may become blocked with contaminants.
As an air conditioner using R410A incurs pressure higher than when using R22, it is necessary to choose adequate materials.
Thicknesses of copper pipes used with R410A are as shown in Table 6-2-1. Never use copper pipes thinner than 0.8 mm even when it is available on the market.

Table 6-2-1 Thicknesses of annealed copper pipes

		Thickness (mm)	
Nominal diameter	Outer diameter (mm)	R410A	R22
1/4	6.35	0.80	0.80
3/8	9.52	0.80	0.80
1/2	12.70	0.80	0.80
5/8	15.88	1.00	1.00

2) Joints

For copper pipes, flare joints or socket joints are used. Prior to use, be sure to remove all contaminants.

a) Flare Joints

Flare joints used to connect the copper pipes cannot be used for pipings whose outer diameter exceeds 20 mm. In such a case, socket joints can be used.

Sizes of flare pipe ends, flare joint ends and flare nuts are as shown in Tables 6-2-3 to 6-2-6 below.

b) Socket Joints

Socket joints are such that they are brazed for connections, and used mainly for thick pipings whose diameter is larger than 20 mm.

Thicknesses of socket joints are as shown in Table 6-2-2.

Table 6-2-2 Minimum thicknesses of socket joints

Nominal diameter	Reference outer diameter of copper pipe jointed (mm)	Minimum joint thickness (mm)
1/4	6.35	0.50
3/8	9.52	0.60
1/2	12.70	0.70
5/8	15.88	0.80

6-2-2. Processing of Piping Materials

When performing the refrigerant piping installation, care should be taken to ensure that water or dust does not enter the pipe interior, that no other oil other than lubricating oils used in the installed air conditioner is used, and that refrigerant does not leak. When using lubricating oils in the piping processing, use such lubricating oils whose water content has been removed. When stored, be sure to seal the container with an airtight cap or any other cover.

1) Flare Processing Procedures and Precautions

a) Cutting the Pipe

By means of a pipe cutter, slowly cut the pipe so that it is not deformed.

b) Removing Burrs and Chips

If the flared section has chips or burrs, refrigerant leakage may occur.

Carefully remove all burrs and clean the cut surface before installation.

c) Insertion of Flare Nut

d) Flare Processing

Make certain that a clamp bar and copper pipe have been cleaned.

By means of the clamp bar, perform the flare processing correctly.

Use either a flare tool for R410A or conventional flare tool.

Flare processing dimensions differ according to the type of flare tool. When using a conventional flare tool, be sure to secure "dimension A" by using a gauge for size adjustment.

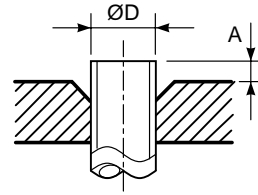

Fig. 6-2-1 Flare processing dimensions

Table 6-2-3 Dimensions related to flare processing for R410A

Nominal diameter	Outer diameter (mm)	Thickness (mm)	A (mm)		
			Flare tool for		Conventional flare tool
			R410A clutch type	Clutch type	
1/4	6.35	0.8	0 to 0.5	1.0 to 1.5	1.5 to 2.0
3/8	9.52	0.8	0 to 0.5	1.0 to 1.5	1.5 to 2.0
1/2	12.70	0.8	0 to 0.5	1.0 to 1.5	2.0 to 2.5
5/8	15.88	1.0	0 to 0.5	1.0 to 1.5	2.0 to 2.5

Table 6-2-4 Dimensions related to flare processing for R22

Nominal diameter	Outer diameter (mm)	Thickness (mm)	A (mm)		
			Flare tool for		Conventional flare tool
			R22 clutch type	Clutch type	
1/4	6.35	0.8	0 to 0.5	0.5 to 1.0	1.0 to 1.5
3/8	9.52	0.8	0 to 0.5	0.5 to 1.0	1.0 to 1.5
1/2	12.70	0.8	0 to 0.5	0.5 to 1.0	1.5 to 2.0
5/8	15.88	1.0	0 to 0.5	0.5 to 1.0	1.5 to 2.0

Table 6-2-5 Flare and flare nut dimensions for R410A

Nominal diameter	Outer diameter (mm)	Thickness (mm)	Dimension (mm)				Flare nut width (mm)
			A	B	C	D	
1/4	6.35	0.8	9.1	9.2	6.5	13	17
3/8	9.52	0.8	13.2	13.5	9.7	20	22
1/2	12.70	0.8	16.6	16.0	12.9	23	26
5/8	15.88	1.0	19.7	19.0	16.0	25	29

Table 6-2-6 Flare and flare nut dimensions for R22

Nominal diameter	Outer diameter (mm)	Thickness (mm)	Dimension (mm)				Flare nut width (mm)
			A	B	C	D	
1/4	6.35	0.8	9.0	9.2	6.5	13	17
3/8	9.52	0.8	13.0	13.5	9.7	20	22
1/2	12.70	0.8	16.2	16.0	12.9	20	24
5/8	15.88	1.0	19.4	19.0	16.0	23	27
3/4	19.05	1.0	23.3	24.0	19.2	34	36

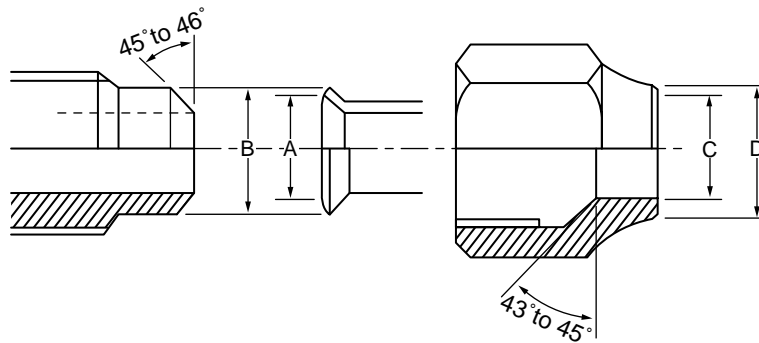

Fig. 6-2-2 Relations between flare nut and flare seal surface

2) Flare Connecting Procedures and Precautions

- a) Make sure that the flare and union portions do not have any scar or dust, etc.
- b) Correctly align the processed flare surface with the union axis.
- c) Tighten the flare with designated torque by means of a torque wrench. The tightening torque for R410A is the same as that for conventional R22. Incidentally, when the torque is weak, the gas leakage may occur. When it is strong, the flare nut may crack and may be made non-removable. When choosing the tightening torque, comply with values designated by manufacturers. Table 6-2-7 shows reference values.

Note)

When applying oil to the flare surface, be sure to use oil designated by the manufacturer. If any other oil is used, the lubricating oils may deteriorate and cause the compressor to burn out.

Table 6-2-7 Tightening torque of flare for R410A [Reference values]

Nominal diameter	Outer diameter (mm)	Tightening torque N•m (kgf•cm)	Tightening torque of torque wrenches available on the market N•m (kgf•cm)
1/4	6.35	14 to 18 (140 to 180)	16 (160), 18 (180)
3/8	9.52	33 to 42 (330 to 420)	42 (420)
1/2	12.70	50 to 62 (500 to 620)	55 (550)
5/8	15.88	63 to 77 (630 to 770)	65 (650)

6-3. Tools

6-3-1. Required Tools

The service port diameter of packed valve of the outdoor unit in the air conditioner using R410A is changed to prevent mixing of other refrigerant. To reinforce the pressure-resisting strength, flare processing dimensions and opposite side dimension of flare nut (For Ø12.7 copper pipe) of the refrigerant piping are lengthened.

The used refrigerating oil is changed, and mixing of oil may cause a trouble such as generation of sludge, clogging of capillary, etc. Accordingly, the tools to be used are classified into the following three types.

- 1) Tools exclusive for R410A (Those which cannot be used for conventional refrigerant (R22))
- 2) Tools exclusive for R410A, but can be also used for conventional refrigerant (R22)
- 3) Tools commonly used for R410A and for conventional refrigerant (R22)

The table below shows the tools exclusive for R410A and their interchangeability.

Tools exclusive for R410A (The following tools for R410A are required.)

Tools whose specifications are changed for R410A and their interchangeability

No.	Used tool	Usage	R410A air conditioner installation		Conventional air conditioner installation
			Existence of new equipment for R410A	Whether conven- tional equipment can be used	Whether new equipment can be used with conventional refrigerant
①	Flare tool	Pipe flaring	Yes	*(Note 1)	○
②	Copper pipe gauge for adjusting projection margin	Flaring by conventional flare tool	Yes	*(Note 1)	*(Note 1)
③	Torque wrench	Connection of flare nut	Yes	✕	✕
④	Gauge manifold	Evacuating, refrigerant charge, run check, etc.	Yes	✕	✕
⑤	Charge hose				
⑥	Vacuum pump adapter	Vacuum evacuating	Yes	✕	○
⑦	Electronic balance for refrigerant charging	Refrigerant charge	Yes	✕	○
⑧	Refrigerant cylinder	Refrigerant charge	Yes	✕	✕
⑨	Leakage detector	Gas leakage check	Yes	✕	○
⑩	Charging cylinder	Refrigerant charge	(Note 2)	✕	✕

Note 1) When flaring is carried out for R410A using the conventional flare tools, adjustment of projection margin is necessary. For this adjustment, a copper pipe gauge, etc. are necessary.

Note 2) Charging cylinder for R410A is being currently developed.

General tools (Conventional tools can be used.)

In addition to the above exclusive tools, the following equipments which serve also for R22 are necessary as the general tools.

- | | | |
|--|-----------------------------|---|
| 1) Vacuum pump | 4) Reamer | 9) Hole core drill (Ø65) |
| Use vacuum pump by
attaching vacuum pump adapter. | 5) Pipe bender | 10) Hexagon wrench
(Opposite side 4mm) |
| 2) Torque wrench | 6) Level vial | 11) Tape measure |
| 3) Pipe cutter | 7) Screwdriver (+, -) | 12) Metal saw |
| | 8) Spanner or Monkey wrench | |

Also prepare the following equipments for other installation method and run check.

- | | |
|----------------|---------------------------------|
| 1) Clamp meter | 3) Insulation resistance tester |
| 2) Thermometer | 4) Electro-scope |

6-4. Recharging of Refrigerant

When it is necessary to recharge refrigerant, charge the specified amount of new refrigerant according to the following steps.

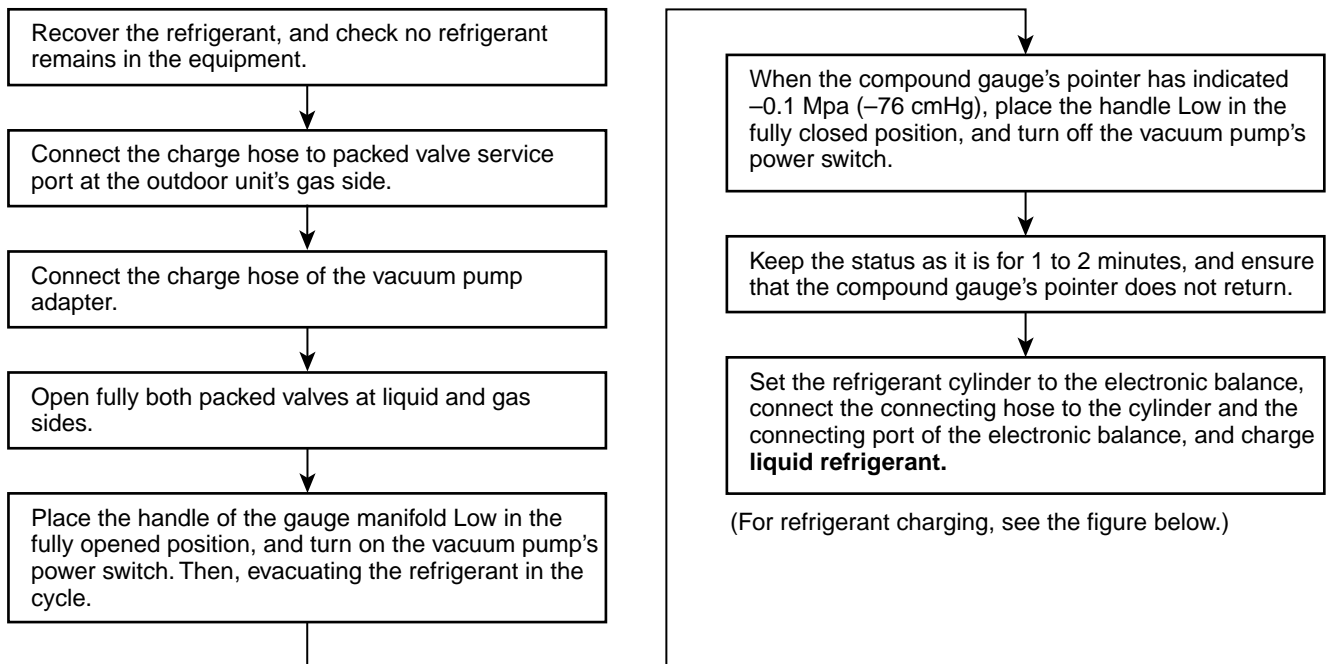

- ① Never charge refrigerant exceeding the specified amount.
- ② If the specified amount of refrigerant cannot be charged, charge refrigerant **bit by bit** in COOL mode.
- ③ Do not carry out additional charging.

When additional charging is carried out if refrigerant leaks, the refrigerant composition changes in the refrigeration cycle, that is characteristics of the air conditioner changes, refrigerant exceeding the specified amount is charged, and working pressure in the refrigeration cycle becomes abnormally high pressure, and may cause a rupture or personal injury.

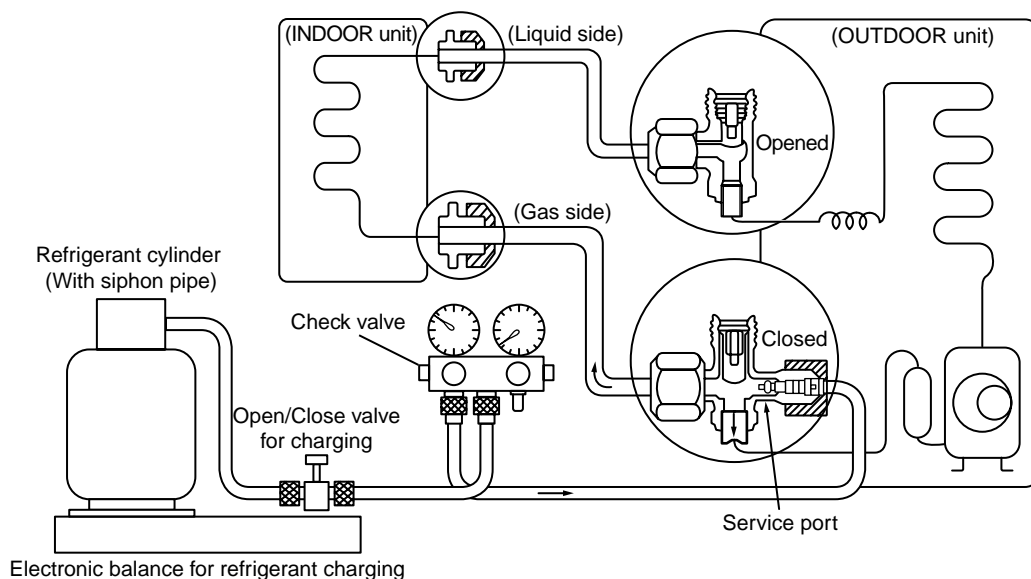
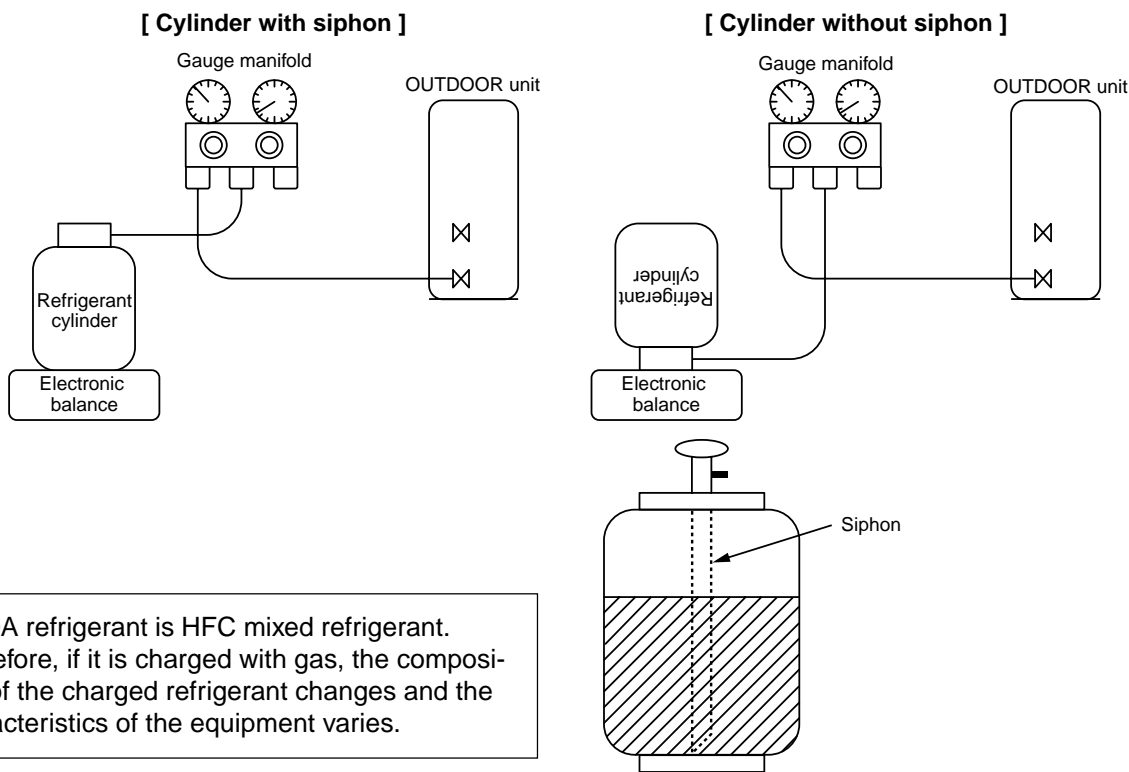

Fig. 6-4-1 Configuration of refrigerant charging

- ① Be sure to make setting so that **liquid** can be charged.
- ② When using a cylinder equipped with a siphon, liquid can be charged without turning it upside down.

It is necessary for charging refrigerant under condition of liquid because R410A is mixed type of refrigerant. Accordingly, when charging refrigerant from the refrigerant cylinder to the equipment, charge it turning the cylinder upside down if cylinder is not equipped with siphon.



R410A refrigerant is HFC mixed refrigerant. Therefore, if it is charged with gas, the composition of the charged refrigerant changes and the characteristics of the equipment varies.

Fig. 6-4-2

6-5. Brazing of Pipes

6-5-1. Materials for Brazing

1) Silver brazing filler

Silver brazing filler is an alloy mainly composed of silver and copper. It is used to join iron, copper or copper alloy, and is relatively expensive though it excels in solderability.

2) Phosphor bronze brazing filler

Phosphor bronze brazing filler is generally used to join copper or copper alloy.

3) Low temperature brazing filler

Low temperature brazing filler is generally called solder, and is an alloy of tin and lead. Since it is weak in adhesive strength, do not use it for refrigerant pipes.

- ① Phosphor bronze brazing filler tends to react with sulfur and produce a fragile compound water solution, which may cause a gas leakage. Therefore, use any other type of brazing filler at a hot spring resort, etc., and coat the surface with a paint.
- ② When performing brazing again at time of servicing, use the same type of brazing filler.

6-5-2. Flux

1) Reason why flux is necessary

- By removing the oxide film and any foreign matter on the metal surface, it assists the flow of brazing filler.
- In the brazing process, it prevents the metal surface from being oxidized.
- By reducing the brazing filler's surface tension, the brazing filler adheres better to the treated metal.

2) Characteristics required for flux

- Activated temperature of flux coincides with the brazing temperature.
- Due to a wide effective temperature range, flux is hard to carbonize.
- It is easy to remove slag after brazing.
- The corrosive action to the treated metal and brazing filler is minimum.
- It excels in coating performance and is harmless to the human body.

As the flux works in a complicated manner as described above, it is necessary to select an adequate type of flux according to the type and shape of treated metal, type of brazing filler and brazing method, etc.

3) Types of flux

• Noncorrosive flux

Generally, it is a compound of borax and boric acid.

It is effective in case where the brazing temperature is higher than 800°C.

• Activated flux

Most of fluxes generally used for silver brazing are this type.

It features an increased oxide film removing capability due to the addition of compounds such as potassium fluoride, potassium chloride and sodium fluoride to the borax-boric acid compound.

4) Piping materials for brazing and used brazing filler/flux

Piping material	Used brazing filler	Used flux
Copper - Copper	Phosphor copper	Do not use
Copper - Iron	Silver	Paste flux
Iron - Iron	Silver	Vapor flux

- ① Do not enter flux into the refrigeration cycle.
- ② When chlorine contained in the flux remains within the pipe, the lubricating oil deteriorates. Therefore, use a flux which does not contain chlorine.
- ③ When adding water to the flux, use water which does not contain chlorine (e.g. distilled water or ion-exchange water).
- ④ Remove the flux after brazing.

6-5-3. Brazing

As brazing work requires sophisticated techniques, experiences based upon a theoretical knowledge, it must be performed by a person qualified.

In order to prevent the oxide film from occurring in the pipe interior during brazing, it is effective to proceed with brazing while letting dry Nitrogen gas (N₂) flow.

Never use gas other than Nitrogen gas.

(1) Brazing method to prevent oxidation

- ① Attach a reducing valve and a flow-meter to the Nitrogen gas cylinder.
- ② Use a copper pipe to direct the piping material, and attach a flow-meter to the cylinder.
- ③ Apply a seal onto the clearance between the piping material and inserted copper pipe for Nitrogen in order to prevent backflow of the Nitrogen gas.
- ④ When the Nitrogen gas is flowing, be sure to keep the piping end open.
- ⑤ Adjust the flow rate of Nitrogen gas so that it is lower than 0.05 m³/Hr or 0.02 MPa (0.2kgf/cm²) by means of the reducing valve.
- ⑥ After performing the steps above, keep the Nitrogen gas flowing until the pipe cools down to a certain extent (temperature at which pipes are touchable with hands).
- ⑦ Remove the flux completely after brazing.

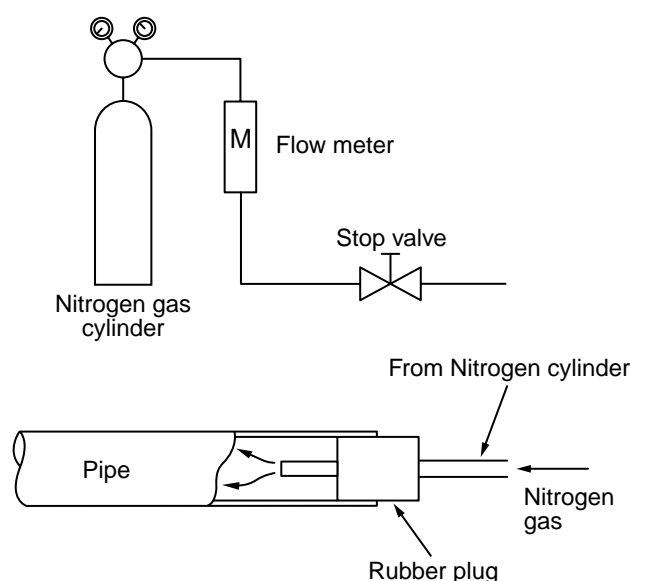
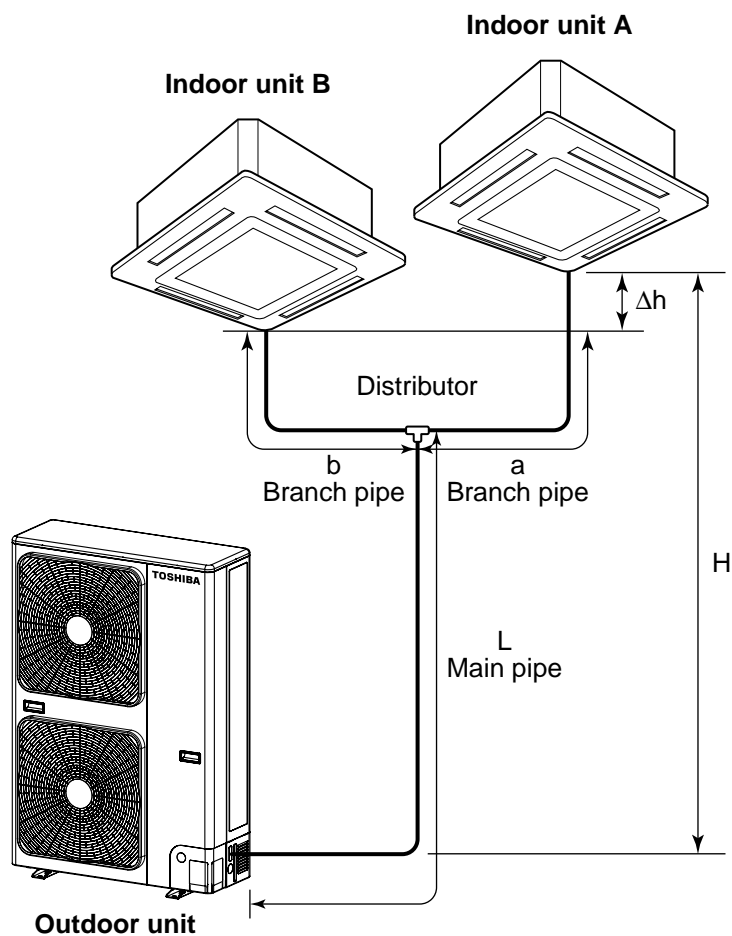

Fig. 6-5-1 Prevention of oxidation during brazing

6-6. Tolerance of Pipe Length and Pipe Head

■ Twin system

Refrigerant pipe specification	Pipe length (one way)	Total length (L + a or L + b)		50 m
		Branch pipe length (a, b)		15 m
		Maximum difference between indoor units (b - a, or a - b)		10 m
	Height difference	Between indoor units (Δh)		0.5 m
		Between indoor unit	When outdoor unit heigher (H)	30 m
		and outdoor unit	When outdoor unit lower (H)	30 m
Number of bent portions				10 m or less



CAUTION

When planning a layout for Units A and B, comply with the following:

1. The lengths after branching ("a" and "b") should be equal if feasible.
Install Units A and B so that the difference of the branching lengths becomes less than 10m if the lengths cannot be equal due to the branch pipe position.
2. Install Units A and B on the same level.
If Units A and B cannot be installed on the same level, the difference in level should be limited to 0.5m or less.
3. Be certain to install Units A and B in the same room.
Units A and B cannot be operated independently each other.

■ Triple system

Refrigerant pipe specification	Pipe length (one way)	Total length (L + a, L +b, L+c)		50 m
		Branch pipe length (a, b, c)		15 m
		Maximum difference between indoor units (a - b , b - c , c - d)		10 m
	Height difference	Between indoor units (Δh)		0.5 m
		Between indoor unit	When outdoor unit heigher (H)	30 m
		and outdoor unit	When outdoor unit lower (H)	30 m
Number of bent portions				10 m or less

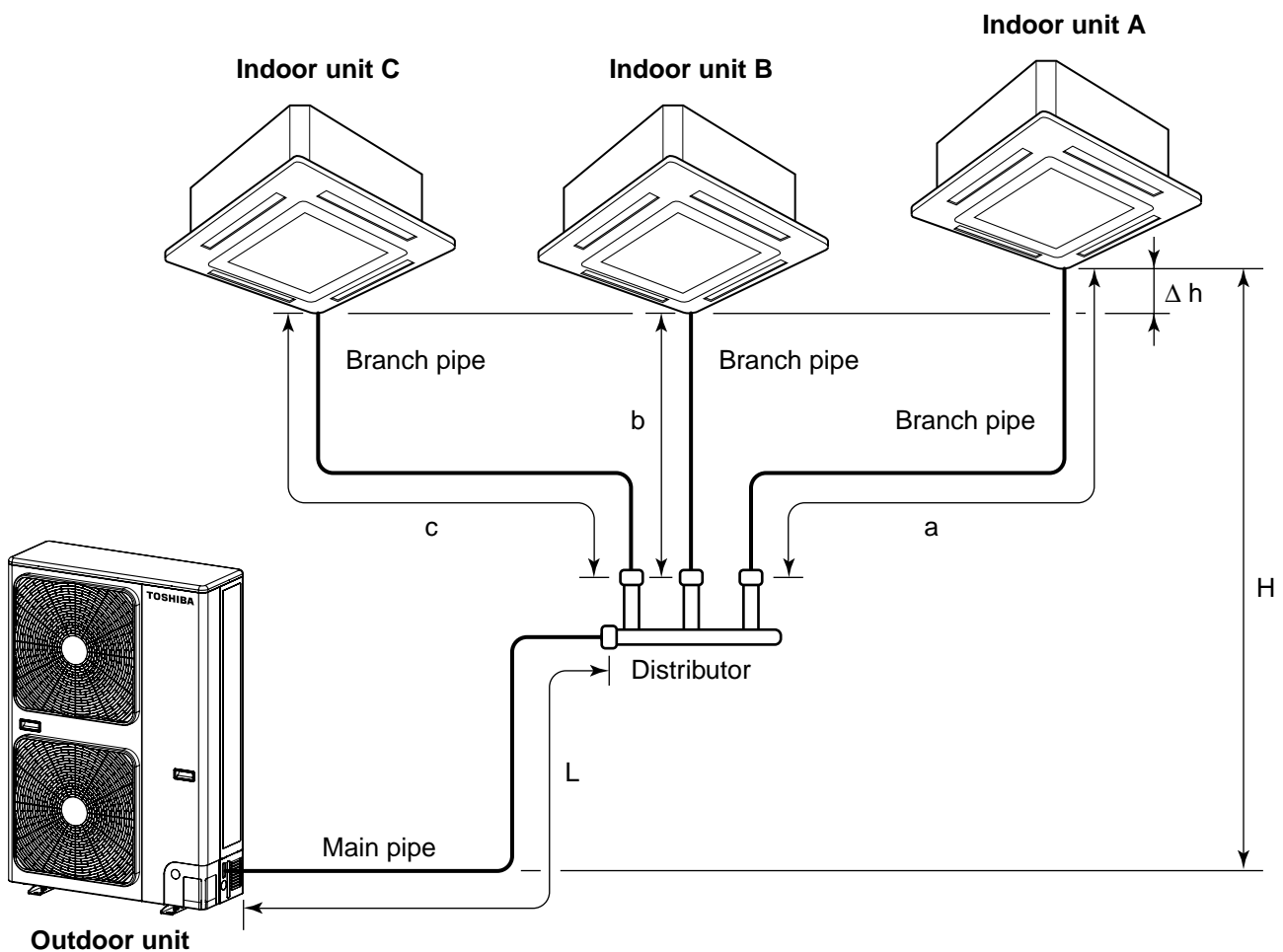

⚠ CAUTION

When planning a layout for Units A, B and C, comply with the following:

1. The lengths after branching ("a" and "b", "b" and "c", "a" and "c") should be equal if feasible.
Install Units A, B and C so that the difference of the branching lengths becomes less than 10m if the lengths cannot be equal due to the branch pipe position.
2. Install Units A, B and C on the same level.
If Units A, B and C cannot be installed on the same level, the difference in level should be limited to 0.5 m or less.
3. Be certain to install Units A and B and C in the same room. Units A, B and C cannot be operated independently each other.

6-7. Additional Refrigerant Amount

■ Twin system

<Formula for Calculating Additional Refrigerant Amount>

Do not remove the refrigerant even if the additional refrigerant amount becomes minus result as a result of calculations by the following formula and operate the air conditioner as it is.

$$\begin{aligned} \text{Additional refrigerant amount (kg)} &= \text{Main piping additional refrigerant amount (kg)} \\ &+ \text{Branch piping additional refrigerant amount (kg)} \\ &= \alpha \times (L - 18) + \gamma \times (a + b - 4) \end{aligned}$$

α : Additional refrigerant amount per meter of actual main piping length (kg)

γ : Additional refrigerant amount per meter of actual branch piping length (kg)

L : Actual length of main piping (m)

a, b : Actual length of branch piping (m)

Standard piping length		Connecting pipe diameter			Additional refrigerant amount per Meter (kg/m)		
Main piping	Branch piping	L	a	b	α	β	γ
18 m	2 m	Ø9.5	Ø6.4	Ø6.4	0.040	—	0.020

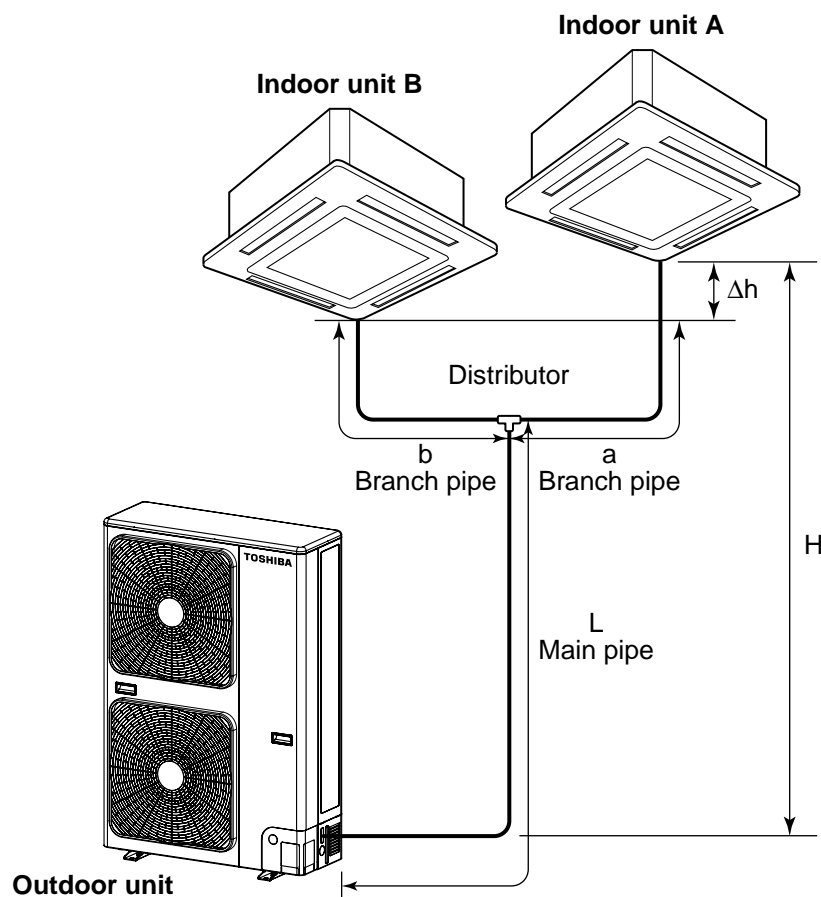

CAUTION

1. Be certain to wire the additional refrigerant amount, pipe length (actual length), head and other specification on the nameplate put on the outdoor unit for recording.
2. Seal the correct amount of additional refrigerant in the system.

■ Triple system

<Formula for Calculating Additional Refrigerant Amount>

Do not remove the refrigerant even if the additional refrigerant amount becomes minus result as a result of calculations by the following formula and operate the air conditioner as it is.

$$\begin{aligned} \text{Additional refrigerant amount (kg)} &= \text{Main piping additional refrigerant amount (kg)} \\ &+ \text{Branch piping additional refrigerant amount (kg)} \\ &= \{\alpha \times (L - 28)\} + \{\gamma \times (a + b + c - 6)\} \end{aligned}$$

α : Additional refrigerant amount per meter of actual main piping length (kg)

γ : Additional refrigerant amount per meter of actual branch piping length (kg)

L : Actual length of main piping (m)

a, b, c : Actual length of branch piping (m)

Connecting pipe diameter				Additional refrigerant amount per Meter (kg/m)		
L	a	b	c	α	β	γ
Ø9.5	Ø6.4	Ø6.4	Ø6.4	0.04	—	0.02

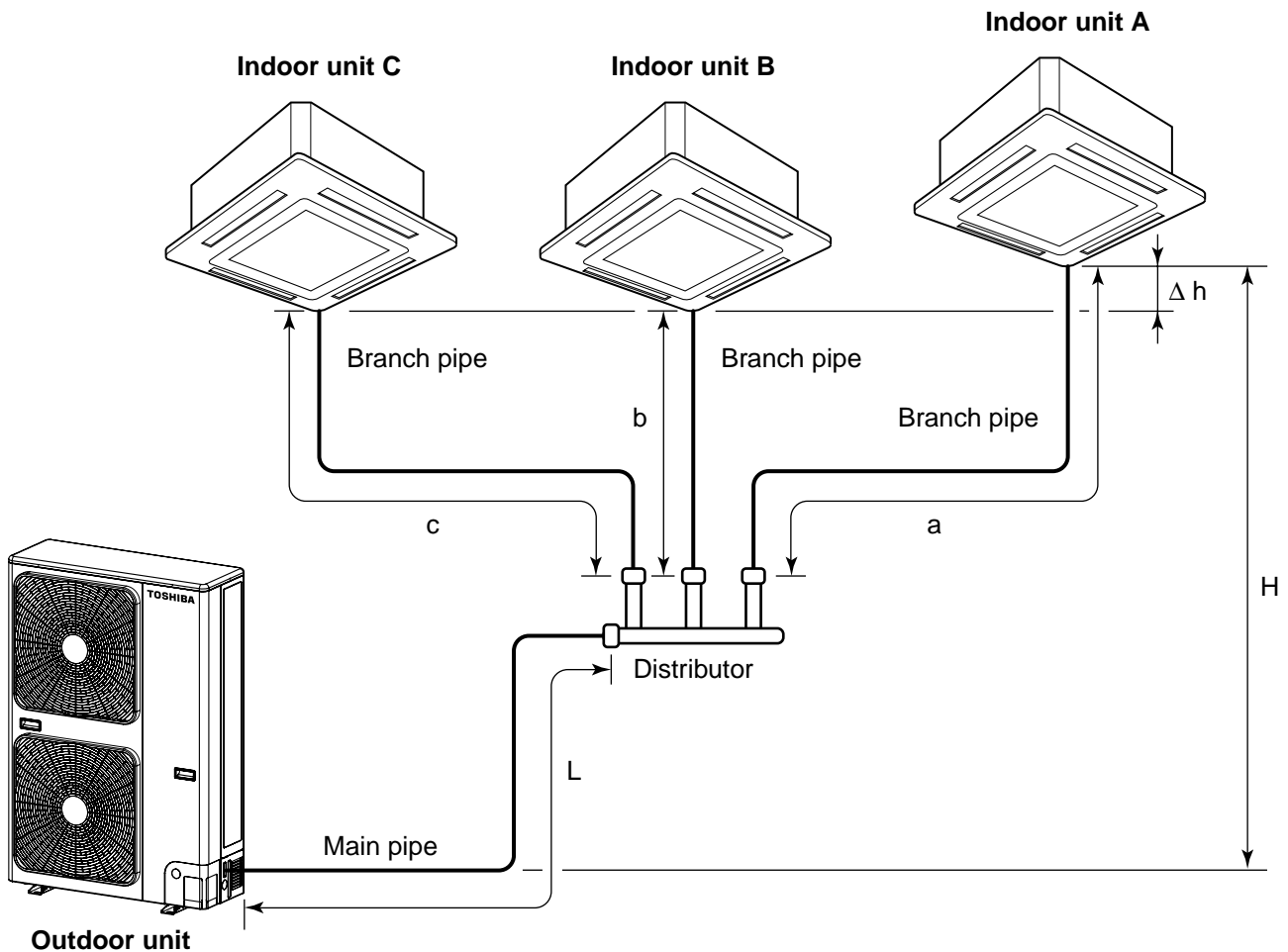

⚠ CAUTION

1. Be certain to wire the additional refrigerant amount, pipe length (actual length), head and other specification on the nameplate put on the outdoor unit for recording.
2. Seal the correct amount of additional refrigerant in the system.

6-8. Piping Materials and Sizes

■ Twin system

Use copper tube of Copper and copper alloy seamless pipes and tubes, with 40mg/10m or less in the amount of oil stuck on inner walls of pipe and 0.8mm in pipe wall thickness for diameters for diameters 6.4, 9.5 and 12.7mm and 1.0mm, for diameter 15.9mm. Never use pipes of thin wall thickness such as 0.7mm.

In parentheses () are wall thickness

Pipe side	Gas side	Main pipe	Ø15.9 (1.0)
		Branch pipe	Ø12.7 (0.8)
	Liquid side	Main pipe	Ø9.5 (0.8)
		Branch pipe	Ø6.4 (0.8)

■ Triple system

Use copper tube of Copper and copper alloy seamless pipes and tubes, with 40 mg/10 m or less in the amount of oil stuck on inner walls of pipe and 0.8 mm in pipe wall thickness for diameters 6.4, 9.5 and 12.7 mm and 1.0 mm, for diameter 15.9 mm. Never use pipes of thin wall thickness such as 0.7 mm.

<Between outdoor unit and distributor>

[Unit: mm]

Outdoor unit		
Main pipe	Gas side	Ø15.9 (1.0)
	Liquid side	Ø9.5 (0.8)

* (): Pipe wall thickness

<Between distributor and indoor unit>

[Unit: mm]

Indoor unit		SM56 type
Branch pipe	Gas side	Ø12.7 (0.8)
	Liquid side	Ø6.4 (0.8)

* (): Pipe wall thickness

6-9. Branch Pipe

■ Twin system

Now the refrigerant pipe is installed using branch pipes supplied as accessories.

- Bend and adjust the refrigerant piping so that the branch pipes and pipe after branching become horizontal.
- Fix the branch pipes onto a wall in a ceiling or onto a column.
- Provide a straight pipe longer than 500mm in length as the main piping of the branches.

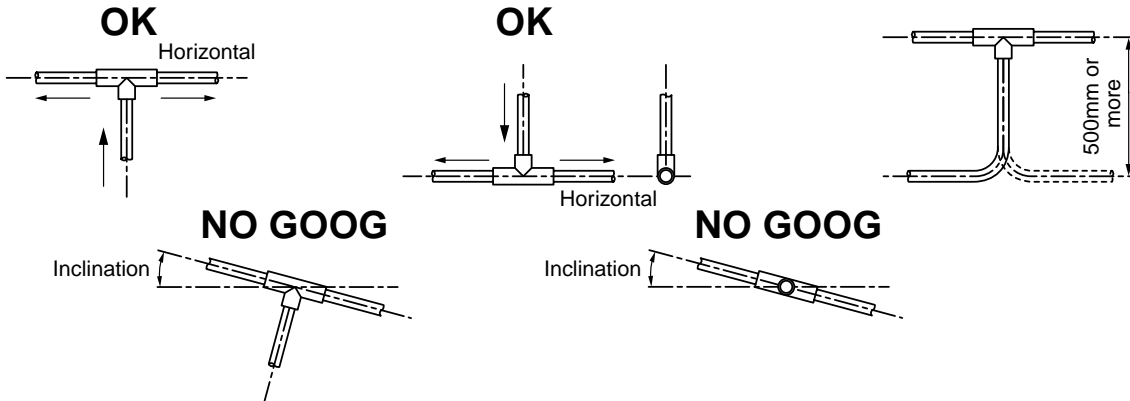

6-10. Distributor

■ Triple system

Now the refrigerant pipe is installed using distributor supplied as accessories.

- Bend and adjust the refrigerant piping so that the distributor and pipe after branching become horizontal.
- Fix the distributor onto a wall in a ceiling or onto a column.
- Provide a straight pipe longer than 500 mm in length as the main piping of the branches.

<How to install distributor>

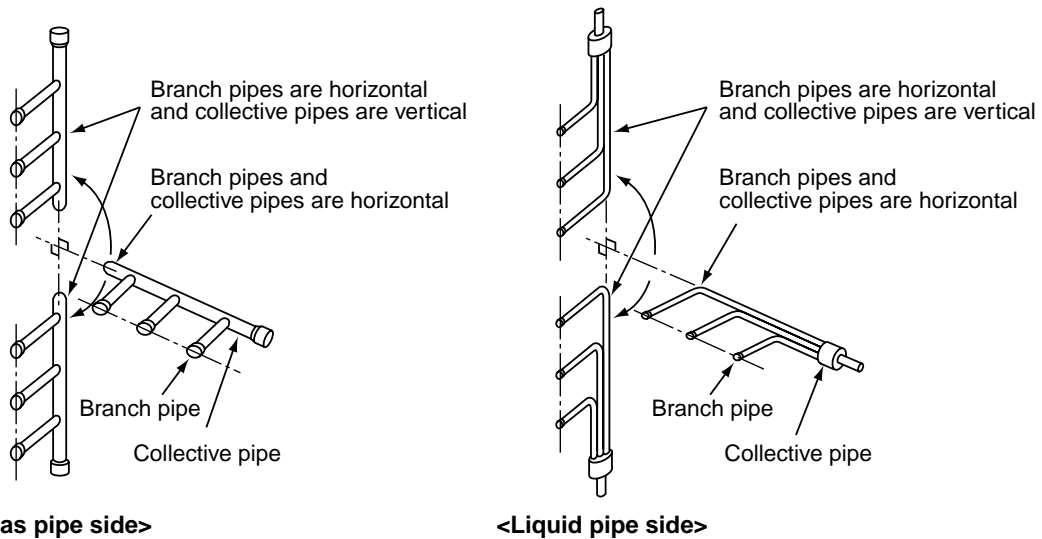

<Restrictions in length of the straight area of the branch pipe (main pipe side)>

Provide a straight area of 500 mm or more on the main pipe side of the branch pipe (for both gas pipe and liquid pipe sides).

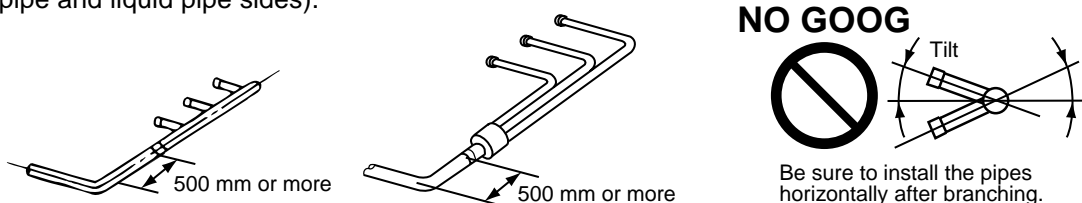

■ Air Purging

For the complete information, read the installation manual for outdoor units of air conditioner.

7. CONTROL BLOCK DIAGRAM

7-1. Indoor Control Circuit

- *1 Connection Interface is attached to master unit.
(In case of group control operation)
- *2 Weekly timer is not connectable to the sub remote controller.

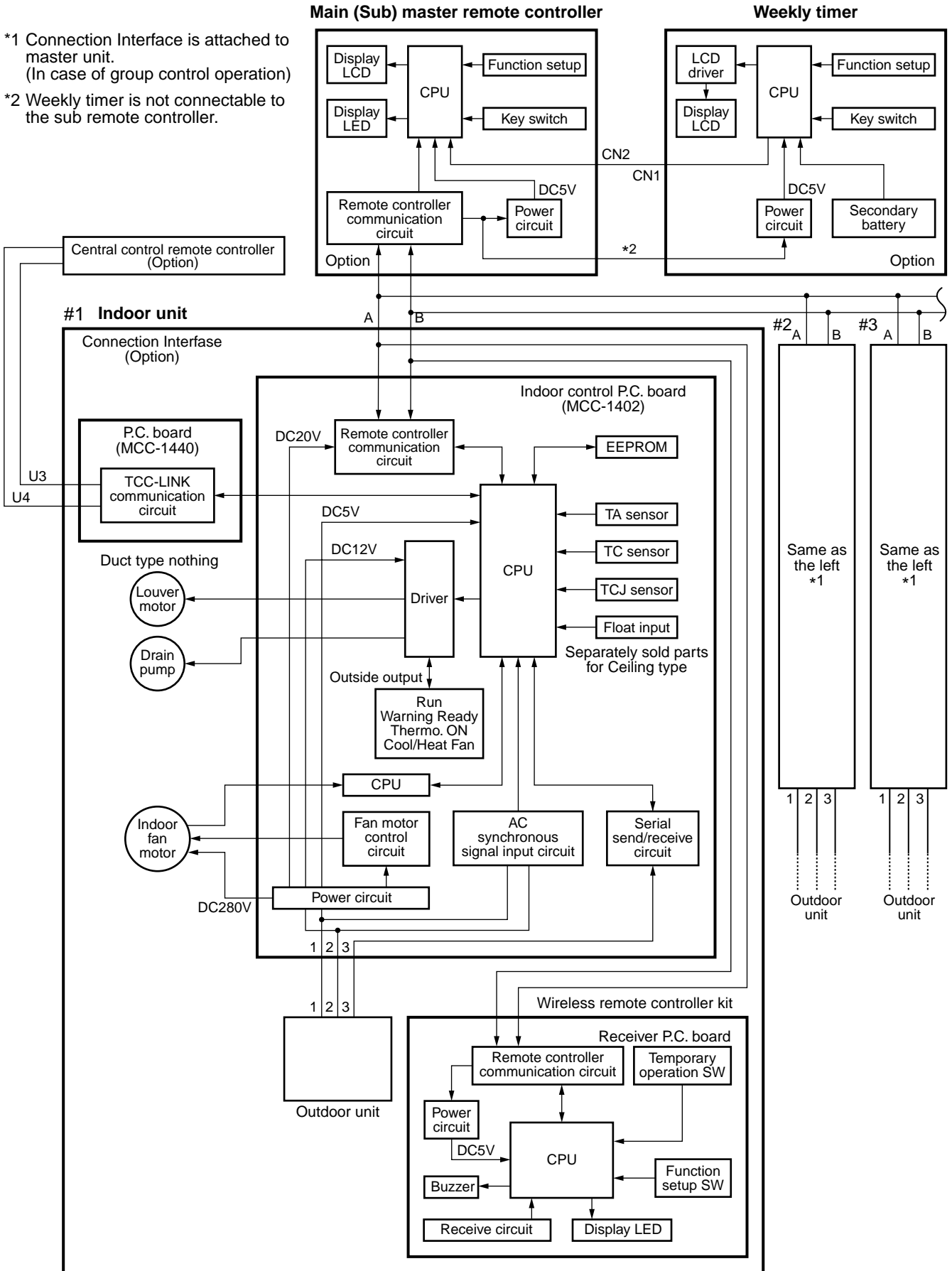



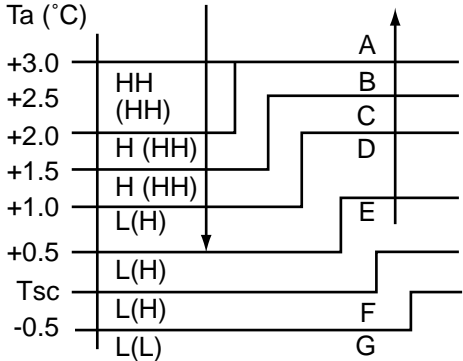

7-2. Control Specifications

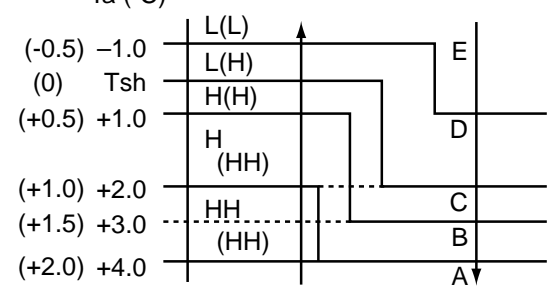
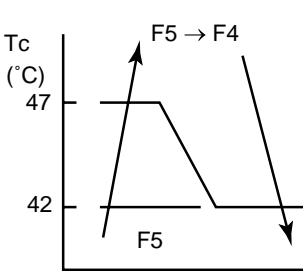
No.	Item	Outline of specifications	Remarks														
1	When power supply is reset	1) Distinction of outdoor units When the power supply is reset, the outdoors are distinguished, and control is exchanged according to the distinguished result. 2) Setting of speed of the indoor fan/setting whether to adjust air direction or not. Based on EEPROM data, speed of the indoor fan or setting whether to adjust air direction or not is selected.	Air speed/ Air direction adjustment														
2	Operation mode selection	1) Based on the operation mode selecting command from the remote controller, the operation mode is selected. <table border="1" data-bbox="459 734 1082 1010" style="margin: 10px auto;"> <thead> <tr> <th>Remote controller command</th> <th>Outline of control</th> </tr> </thead> <tbody> <tr> <td>STOP</td> <td>Air conditioner stops.</td> </tr> <tr> <td>FAN</td> <td>Fan operation</td> </tr> <tr> <td>COOL</td> <td>Cooling operation</td> </tr> <tr> <td>DRY</td> <td>Dry operation</td> </tr> <tr> <td>HEAT</td> <td>Heating operation</td> </tr> <tr> <td>AUTO</td> <td> <ul style="list-style-type: none"> COOL/HEAT operation mode is automatically selected by T_a and T_s for operation. </td> </tr> </tbody> </table> <div data-bbox="571 1104 997 1373" style="text-align: center;"> </div> <p data-bbox="469 1395 1070 1451">1) Judge the selection of COOL/HEAT mode as shown in the figure above.</p> <p data-bbox="501 1473 1023 1585">When 10 minutes passed after thermostat had been turned off, the heating operation (Thermo OFF) is exchanged to cooling operation if T_{sh} exceeds +1.5 or more.</p> <p data-bbox="501 1615 1059 1671">(COOL OFF) and (COOL ON) in the figure indicate an example.</p> <p data-bbox="501 1693 1018 1805">When 10 minutes passed after thermostat had been turned off, the cooling operation (Thermo OFF) is exchanged to heating operation if T_{sc} exceeds -1.5 or less.</p> <p data-bbox="469 1827 1070 1939">2) For the automatic capacity control after judgment of COOL/HEAT, refer to item 4. 3) For the temperature correction of room temperature control in automatic heating operation, refer to item 3.</p>	Remote controller command	Outline of control	STOP	Air conditioner stops.	FAN	Fan operation	COOL	Cooling operation	DRY	Dry operation	HEAT	Heating operation	AUTO	<ul style="list-style-type: none"> COOL/HEAT operation mode is automatically selected by T_a and T_s for operation. 	T_a : Room temperature T_s : Setup temperature T_{sc} : Setup temperature in cooling operation T_{sh} : Setup temperature + Room temperature control temperature compensation
Remote controller command	Outline of control																
STOP	Air conditioner stops.																
FAN	Fan operation																
COOL	Cooling operation																
DRY	Dry operation																
HEAT	Heating operation																
AUTO	<ul style="list-style-type: none"> COOL/HEAT operation mode is automatically selected by T_a and T_s for operation. 																

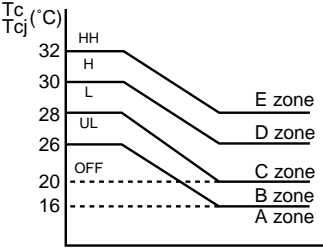
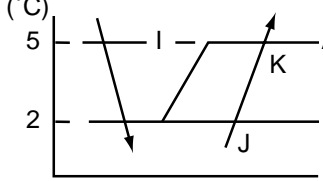
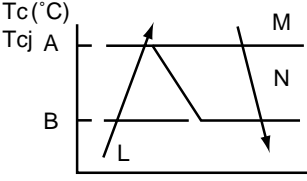

No.	Item	Outline of specifications	Remarks																								
3	Room temperature control	<p>1) Adjustment range Remote controller setup temperature (°C)</p> <table border="1" data-bbox="475 286 1082 443"> <thead> <tr> <th></th> <th>COOL/ DRY</th> <th>Heating operation</th> <th>Auto operation</th> </tr> </thead> <tbody> <tr> <td>Wired type</td> <td>18 to 29</td> <td>18 to 29</td> <td>18 to 29</td> </tr> <tr> <td>Wireless type</td> <td>18 to 30</td> <td>16 to 30</td> <td>17 to 27</td> </tr> </tbody> </table> <p>2) Using the item code 06, the setup temperature in heating operation can be compensated.</p> <table border="1" data-bbox="475 528 1082 645"> <tbody> <tr> <td>Setup data</td> <td>0</td> <td>2</td> <td>4</td> <td>6</td> </tr> <tr> <td>Setup temp. compensation</td> <td>+0°C</td> <td>+2°C</td> <td>+4°C</td> <td>+6°C</td> </tr> </tbody> </table> <p>Setting at shipment</p> <table border="1" data-bbox="475 698 762 743"> <tbody> <tr> <td>Setup data</td> <td>2</td> </tr> </tbody> </table>		COOL/ DRY	Heating operation	Auto operation	Wired type	18 to 29	18 to 29	18 to 29	Wireless type	18 to 30	16 to 30	17 to 27	Setup data	0	2	4	6	Setup temp. compensation	+0°C	+2°C	+4°C	+6°C	Setup data	2	Shift of suction temperature in heating operation
	COOL/ DRY	Heating operation	Auto operation																								
Wired type	18 to 29	18 to 29	18 to 29																								
Wireless type	18 to 30	16 to 30	17 to 27																								
Setup data	0	2	4	6																							
Setup temp. compensation	+0°C	+2°C	+4°C	+6°C																							
Setup data	2																										
4	Automatic capacity control (GA control)	1) Based on the difference between Ta and Ts, the operation frequency is instructed to the outdoor unit.																									
5	Air speed selection	<p>1) Operation with (HH), (H), (L), or [AUTO] mode is performed by the command from the remote controller.</p> <p>2) When the air speed mode [AUTO] is selected, the air speed varies by the difference between Ta and Ts.</p> <p><COOL></p>  <ul style="list-style-type: none"> • Controlling operation in case when thermo of remote controller works is same as a case when thermo of the body works. • If the air speed has been changed once, it is not changed for 3 minutes. However when the air volume is exchanged, the air speed changes. • When cooling operation has started, the air speed selects a downward slope, that is, the high position. • If the temperature is just on the difference boundary, the air speed does not change. • Mode in the parentheses indicates one in automatic cooling operation. 	HH > H > L > LL																								

No.	Item	Outline of specifications	Remarks																																																																																																								
5	Air speed selection (Continued)	<p><HEAT></p> <p>Ta (°C)</p>  <p>Value in the parentheses indicates one when thermostat of the remote controller works. Value without parentheses indicates one when thermostat of the body works.</p> <ul style="list-style-type: none"> • If the air speed has been changed once, it is not changed for 1 minute. However when the air speed is exchanged, the air speed changes. • When heating operation has started, the air speed selects a upward slope, that is, the high position. • If the temperature is just on the difference boundary, the air speed does not change. • Mode in the parentheses indicates one in automatic heating operation. • In $T_c \geq 60^\circ\text{C}$, the air speed increases by 1 step. <p><Operation of duct only></p> <table border="1" data-bbox="391 1097 1085 1601"> <thead> <tr> <th colspan="2">Standard</th> <th colspan="2">High ceiling</th> <th rowspan="2">Tap</th> <th>SM562</th> <th>SM402 SM452</th> </tr> <tr> <th>COOL</th> <th>HEAT</th> <th>COOL</th> <th>HEAT</th> <th colspan="2">Revolutions per minute (rpm)</th> </tr> </thead> <tbody> <tr> <td>UL</td> <td>UL</td> <td></td> <td></td> <td>FD</td> <td>360</td> <td>360</td> </tr> <tr> <td>L</td> <td></td> <td></td> <td></td> <td>FD</td> <td>610</td> <td>550</td> </tr> <tr> <td>L+</td> <td>L</td> <td></td> <td></td> <td>FB</td> <td>610</td> <td>550</td> </tr> <tr> <td></td> <td>L+</td> <td></td> <td></td> <td>FA</td> <td>670</td> <td>590</td> </tr> <tr> <td>M</td> <td></td> <td></td> <td></td> <td>F9</td> <td>730</td> <td>640</td> </tr> <tr> <td></td> <td>M</td> <td>UL</td> <td>UL</td> <td>F8</td> <td>730</td> <td>640</td> </tr> <tr> <td>M+</td> <td>M+</td> <td>L</td> <td>L</td> <td>F7</td> <td>790</td> <td>690</td> </tr> <tr> <td>H</td> <td></td> <td>L+</td> <td>L+</td> <td>F6</td> <td>850</td> <td>750</td> </tr> <tr> <td></td> <td>H</td> <td></td> <td></td> <td>F5</td> <td>850</td> <td>750</td> </tr> <tr> <td></td> <td></td> <td></td> <td></td> <td>F4</td> <td>870</td> <td>790</td> </tr> <tr> <td></td> <td></td> <td>M+,M</td> <td>M+,M</td> <td>F3</td> <td>880</td> <td>830</td> </tr> <tr> <td></td> <td></td> <td></td> <td></td> <td>F2</td> <td>880</td> <td>830</td> </tr> <tr> <td></td> <td></td> <td>H</td> <td>H</td> <td>F1</td> <td>900</td> <td>900</td> </tr> </tbody> </table> <p>Tc: Indoor heat exchanger sensor temperature</p> <ol style="list-style-type: none"> In heating operation, the mode changes to [UL] if thermostat is turned off. If $T_a \geq 25^\circ\text{C}$ when heating operation has started and when defrost operation has been cleared, it operates with HIGH (H) mode or (HH) for 1 minute from when Tc has entered in E zone of cool air discharge preventive control (Item 6). In automatic cooling/heating operation, the revolution frequency of [HH] is set larger than that in the standard cooling/heating operation. However the revolution frequency is restricted in the automatic heating operation as shown in the following figure. 	Standard		High ceiling		Tap	SM562	SM402 SM452	COOL	HEAT	COOL	HEAT	Revolutions per minute (rpm)		UL	UL			FD	360	360	L				FD	610	550	L+	L			FB	610	550		L+			FA	670	590	M				F9	730	640		M	UL	UL	F8	730	640	M+	M+	L	L	F7	790	690	H		L+	L+	F6	850	750		H			F5	850	750					F4	870	790			M+,M	M+,M	F3	880	830					F2	880	830			H	H	F1	900	900	<p>[PRE-HEAT] display</p> 
Standard		High ceiling		Tap	SM562	SM402 SM452																																																																																																					
COOL	HEAT	COOL	HEAT		Revolutions per minute (rpm)																																																																																																						
UL	UL			FD	360	360																																																																																																					
L				FD	610	550																																																																																																					
L+	L			FB	610	550																																																																																																					
	L+			FA	670	590																																																																																																					
M				F9	730	640																																																																																																					
	M	UL	UL	F8	730	640																																																																																																					
M+	M+	L	L	F7	790	690																																																																																																					
H		L+	L+	F6	850	750																																																																																																					
	H			F5	850	750																																																																																																					
				F4	870	790																																																																																																					
		M+,M	M+,M	F3	880	830																																																																																																					
				F2	880	830																																																																																																					
		H	H	F1	900	900																																																																																																					

No.	Item	Outline of specifications	Remarks						
6	Cool air discharge preventive control	<p>1) In heating operation, the indoor fan is controlled based on the detected temperature of Tc sensor or Tcj sensor. As shown below, the upper limit of the revolution frequency is determined.</p> 	<p>In D or E zone, the priority is given to setup of air volume exchange. In A and B zones, [PRE-HEAT] is displayed.</p>						
7	Freeze preventive control (Low temperature release)	<p>1) The cooling operation (including Dry operation) is performed as follows based on the detected temperature of Tc sensor or Tcj sensor.</p> <p>When [J] zone is detected for 6 minutes (Following figure), the commanded frequency is decreased from the real operation frequency. After then the commanded frequency changes every 30 seconds while operation is performed in [J] zone.</p> <p>In [K] zone, time counting is interrupted and the operation is held.</p> <p>When [I] zone is detected, the timer is cleared and the operation returns to the normal operation.</p> <p>If the commanded frequency becomes S0 because the operation continues in [J] zone, the return temperature A is raised from 5°C to 12°C until [I] zone is detected and the indoor fan operates with [M] mode.</p>  <p>In heating operation, the freeze-preventive control works if 4-way valve is not exchanged and the condition is satisfied. (However the temperature for J zone dashing control is changed from 2°C to -5°C.)</p>	Tcj : Indoor heat exchanger sensor temperature						
8	High-temp release control	<p>1) The heating operation is performed as follows based on the detected temperature of Tc sensor or Tcj sensor.</p> <ul style="list-style-type: none"> • When [M] zone is detected, the commanded frequency is decreased from the real operation frequency. After then the commanded frequency changes every 30 seconds while operation is performed in [M] zone. • In [N] zone, the commanded frequency is held. • When [L] zone is detected, the commanded frequency is returned to the original value by approx. 6Hz every 60 seconds. <p>Setup at shipment</p> <table border="1" data-bbox="534 1787 762 1915"> <thead> <tr> <th colspan="2">Control temp (°C)</th> </tr> <tr> <th>A</th> <th>B</th> </tr> </thead> <tbody> <tr> <td>56 (54)</td> <td>52 (52)</td> </tr> </tbody> </table>  <p>NOTE : When the operation has started or when Tc or Tcj became lower than 30°C after start of the operation, temperature is controlled between values in parentheses of A and B.</p>	Control temp (°C)		A	B	56 (54)	52 (52)	Same when thermostat is turned off.
Control temp (°C)									
A	B								
56 (54)	52 (52)								

No.	Item	Outline of specifications	Remarks
9	Drain pump control	1) In cooling operation (including Dry operation), the drain pump is usually operated. 2) If the float switch operates while drain pump operates, the compressor stops, the drain pump continues the operation, and a check code is output. 3) If the float switch operates while drain pump stops, the compressor stops and the drain pump operates. If the float switch keeps operating for approx. 4 minutes, a check code is output.	Check code [P10]
10	After-heat elimination	When heating operation stops, the indoor fan operates with LOW mode for approx. 30 seconds.	
11	Flap control	1) Flap position setup <ul style="list-style-type: none"> • When the flap position is changed, the position moves necessarily to downward discharge position once to return to the set position. • The flap position can be set up in the following operation range. <p style="text-align: center;">In cooling/dry operation In heating/fan operation</p> <div style="display: flex; justify-content: space-around; align-items: center;">   </div> <ul style="list-style-type: none"> • In group twin/triple operation, the flap positions can be set up collectively or individually. 2) Swing setup <ul style="list-style-type: none"> • The swinging position can be moved in the following operation range. <p style="text-align: center;">All modes</p> <div style="text-align: center;">  </div> <ul style="list-style-type: none"> • In group twin/triple operation, the swinging positions can be set up collectively or individually. 3) When the unit stops or when a warning is output, the flap automatically moves downward. 4) While the heating operation is ready, the flap automatically moves upward.	<p>Warning : A check code is displayed on the remote controller, and the indoor unit stops. (Excluding [F08] and [L31])</p>

No.	Item	Outline of specifications	Remarks
12	Frequency fixed operation (Test run)	<p><In case of wired remote controller></p> <ol style="list-style-type: none"> 1. When pushing [CHECK] button for 4 seconds or more, [TEST] is displayed on the display screen and the mode enters in Test run mode. 2. Push [ON/OFF] button. 3. Using [MODE] button, change the mode from [COOL] to [HEAT]. <ul style="list-style-type: none"> • Do not use other mode than [COOL]/[HEAT] mode. • During test run operation, the temperature cannot be adjusted. • An error is detected as usual. • A frequency fixed operation is performed. 4. After the test run, push [ON/OFF] button to stop the operation. (Display in the display part is same as the procedure in item 1.) 5. Push [CHECK] button to clear the test run mode. ([TEST] display in the display part disappears and the status returns to the normal stop status.) <p><In case of wireless remote controller></p> <ol style="list-style-type: none"> 1. Turn off the power of the set. Remove the adjuster with sensors from the ceiling panel. 2. Turn Bit [1: TEST] of sensor P.C. board switch [S003] from OFF to ON. Attach the sensor P.C. board cover and mount the adjuster with sensors to the ceiling panel. Turn on the power of the set. 3. Push [ON/OFF] button of the wireless remote controller and set the operation mode to [COOL] or [HEAT] using [MODE] button. (During test run operation, all the display lamps of wireless remote controller sensors flash.) <ul style="list-style-type: none"> • Do not use other mode than [COOL]/[HEAT] mode. • An error is detected as usual. • A frequency fixed operation is performed. 4. After the test run, push [ON/OFF] button to stop the operation. 5. Turn off the power of the set. Turn Bit [1: TEST] of sensor P.C. board switch [S003] from ON to OFF. Mount the adjuster with sensors to the ceiling panel. 	
13	Filter sign display (Except wireless type)	<ol style="list-style-type: none"> 1) The operation time of the indoor fan is calculated, the filter reset signal is sent to the remote controller when the specified time (2500H) has passed, and it is displayed on LCD. 2) When the filter reset signal has been received from the remote controller, time of the calculation timer is cleared. In this case, the measurement time is reset if the specified time has passed, and display on LCD disappears. 	[FILTER] goes on.

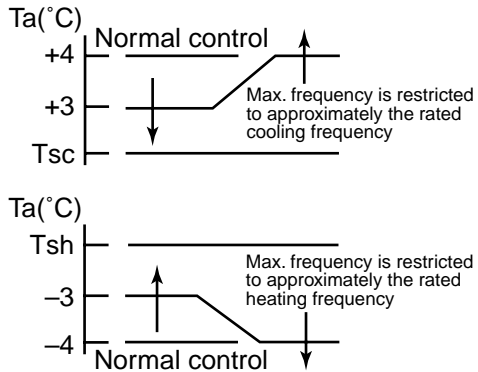
No.	Item	Outline of specifications	Remarks
14	Central control mode selection	1) Setting at the central controller side enables to select the contents which can be operated on the remote controller at indoor unit side. 2) RBC-AMT31E, RBC-AMT32E [Last push priority] : The operation contents can be selected from both remote controller and central controller of the indoor unit side, and the operation is performed with the contents selected at the last. [Center] : Start/Stop operation only can be handled on the remote controller at indoor unit side. [Operation Prohibited] : It cannot be operated on the remote controller at indoor unit side. (Stop status is held.)	(No display) [] goes on. [] goes on. In a case of wireless type, the display lamp does not change. However, contents which can be operated are same. The status set in [] / [Operation Prohibited] mode is notified with the receiving sound "Pi, Pi, Pi, Pi, Pi" (5 times).
15	Energy-save control (By connected outdoor unit)	1) Selecting [AUTO] mode enables an energy-saving to be operated. 2) The setup temperature is shifted (corrected) in the range not to lose the comfort ability according to input values of various sensors. 3) Data (Input value room temp. Ta, Outside temp. To, Air volume, Indoor heat exchanger sensor temp. Tc) for 20 minutes are taken the average to calculate correction value of the setup temperature. 4) The setup temperature is shifted every 20 minutes, and the shifted range is as follows. In cooling time : +1.5 to -1.0K In heating time : -1.5 to +1.0K	
16	Max. frequency cut control	1) This control is operated by selecting [AUTO] operation mode. 2) COOL operation mode: the frequency is controlled according to the following figure if $T_o < 28^{\circ}\text{C}$. 3) HEAT operation mode: the frequency is controlled according to the right figure if $T_o > 15^{\circ}\text{C}$.	
17	DC motor	1) When the fan operation has started, positioning of the stator and the rotor are performed. (Moves slightly with tap sound) 2) The motor operates according to the command from the indoor controller. NOTES : <ul style="list-style-type: none"> • When the fan rotates while the air conditioner stops due to entering of outside air, etc, the air conditioner may operated while the fan motor stops. • When a fan locking is found, the air conditioner stops, and an error is displayed. 	Check code [P12]

7-3. Indoor Print Circuit Board
7-3-1. Compact 4-way Cassette Type
<MCC-1402>

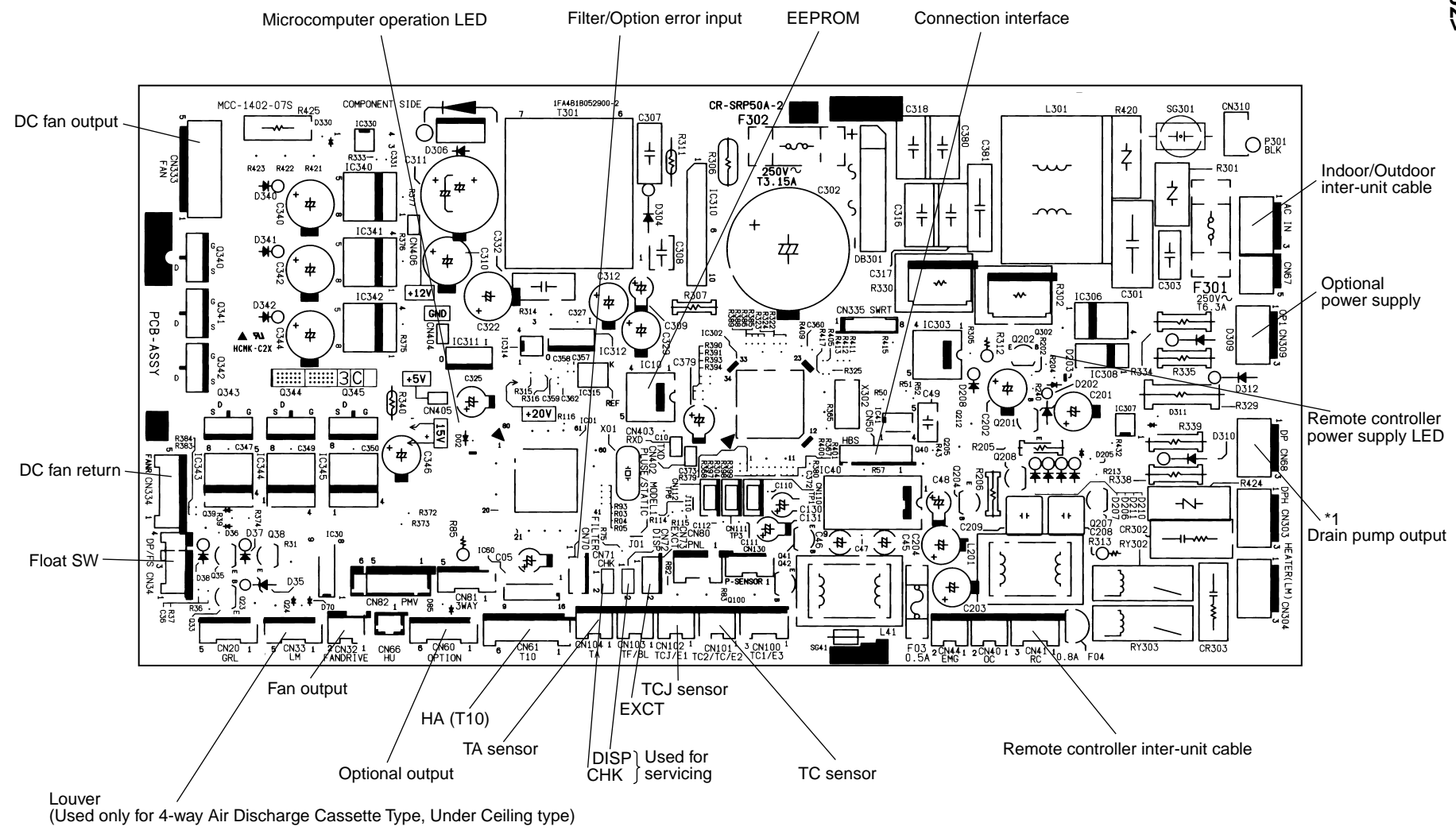

8. CIRCUIT CONFIGURATION AND CONTROL SPECIFICATIONS

8-1. Indoor Control Circuit

8-1-1. Outline of Main Controls

1. Pulse Motor Valve (P.M.V.) control

- 1) PMV is controlled with 50 to 500 pulses during operation, respectively.
- 2) In cooling operation, PMV is controlled with the temperature difference between TS sensor and TC sensor.
- 3) In heating operation, PMV is controlled with the temperature difference between TS sensor and TE sensor.
- 4) For the temperature difference in items 2) and 3), 1 to 5K is aimed as the target in both cooling and heating operations.
- 5) When the cycle excessively rose in both cooling and heating operations, PMV is controlled by TD sensor. The aimed value is usually 106°C for SP404, SP454, SM562, SM563, 100°C for SP562 in both cooling and heating operations.

CAUTION

A sensor trouble may cause a liquid back-flow or abnormal overheat resulting in excessive shortening of the compressor life. In a case of trouble on the compressor, be sure to check there is no error in the resistance value an the refrigerating cycle of each sensor after repair and then start the operation.

2. Discharge temperature release control

- 1) This function controls the operation frequency, that is, lowers the operation frequency when the discharge temperature has not lower or the discharge temperature has rapidly risen during P.M.V. control. It subdivides the frequency control up to a unit of 0.6Hz to stabilize the cycle.
- 2) When the discharge temperature is detected in an abnormal stop zone, the unit stops the compressor and restarts after 2 minutes 30 seconds. The error counter is cleared when it has continued the operation for 10 minutes. If the abnormal stop zone has been detected by 8 times without clearing of counter, an error "P03" is displayed.
 - * The cause is considered as excessively little amount of refrigerant, defective PMV, or clogging of cycle.

[°C]

	a	b	c	d	e
SM562, SM563, SP404, SP454	117	107	103	100	93
SP562	111	106	100	95	90

TD [°C]

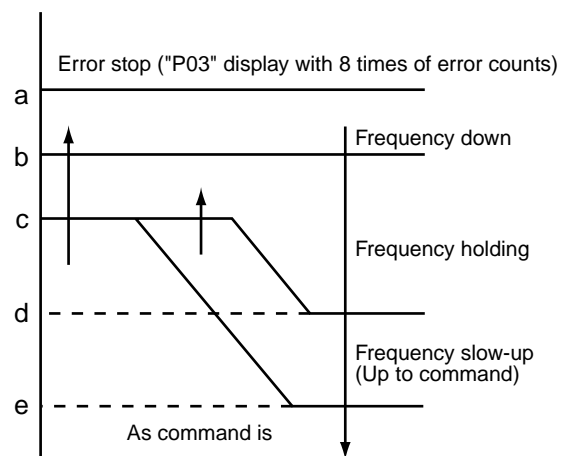

[A]

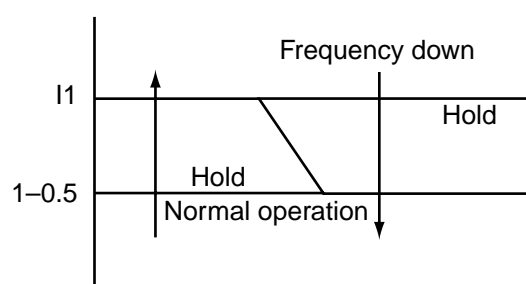

3. Current release control

The output frequency and the output voltage are controlled by AC current value detected by T02 on the outdoor P.C. board so that input current of the inverter does not exceed the specified value.

Objective model	I1 value [A]	
	COOL	HEAT
SM562, SM563	10.13	12.00
SP404, SP454	10.13	10.50
SP562	11.55	13.43

* For the cooling only models, only COOL is objective.

8-1-2. Indoor P.C. Board Optional Connector Specifications

Function	Connector No.	Pin No.	Specifications	Remarks
Option output	CN60	1	DC12V (COM)	
		2	Defrost output	ON during defrost operation of outdoor unit
		3	Thermo. ON output	ON during Real thermo-ON (Comp ON)
		4	Cooling output	ON when operation mode is in cooling system (COOL, DRY, COOL in AUTO cooling/heating)
		5	Heating output	ON when operation mode is in heating system (HEAT, HEAT in AUTO cooling/heating)
		6	Fan output	ON during indoor fan ON (Air purifier is used/Interlock cable)
Outside error input	CN80	1	DC12V (COM)	(When continued for 1 minute) Check code "L30" is output and forced operation stops.
		2	DC12V (COM)	
		3	Outside error input	
Filter option error	CN70	1	Filter/Option/Humidifier setup input	Option error input is controlled. (Protective operation for device attached to outside is displayed.)
		2	0V	* Setting of option error input is performed from remote controller. (DN=2A)
CHK Operation check	CN71	1	Check mode input	Used for operation check of indoor unit. (Communication with outdoor unit or remote controller is not performed, but the specified operation such as indoor fan "H" or drain pump ON is output.)
		2	0V	
DISP display mode	CN72	1	Display mode input	Display mode enables indoor unit and remote controller to communicate. (When power is turned on)
		2	0V	
EXCT demand	CN73	1	Demand input	Forced thermo-OFF operation in indoor unit
		2	0V	

9. TROUBLESHOOTING

9-1. Summary of Troubleshooting

<Wired remote controller type>

1. Before troubleshooting

1) Required tools/instruments

- ⊕ and ⊖ screwdrivers, spanners, radio cutting pliers, nippers, push pins for reset switch
- Tester, thermometer, pressure gauge, etc.

2) Confirmation points before check

a) The following operations are normal.

1. Compressor does not operate.

- Is not 3-minutes delay (3 minutes after compressor OFF)?
- Does not thermostat turn off?
- Does not timer operate during fan operation?
- Is not outside high-temperature operation controlled in heating operation?

2. Indoor fan does not rotate.

- Does not cool air discharge preventive control work in heating operation?

3. Outdoor fan does not rotate or air volume changes.

- Does not high-temperature release operation control work in heating operation?
- Does not outside low-temperature operation control work in cooling operation?
- Is not defrost operation performed?

4. ON/OFF operation cannot be performed from remote controller.

- Is not the control operation performed from outside/remote side?
- Is not automatic address being set up?

(When the power is turned on at the first time or when indoor unit address setting is changed, the operation cannot be performed for maximum approx. 5 minutes after power-ON.)

b) Did you return the cabling to the initial positions?

c) Are connecting cables of indoor unit and remote controller correct?

2. Troubleshooting procedure

When a trouble occurred, check the parts along with the following procedure.



NOTE :

For cause of a trouble, power conditions or malfunction/erroneous diagnosis of microcomputer due to outer noise is considered except the items to be checked. If there is any noise source, change the cables of the remote controller to shield cables.

<Wireless remote controller type>

1. Before troubleshooting

- 1) Required tools/instruments
 - ⊕ and ⊖ screwdrivers, spanners, radio cutting pliers, nippers, etc.
 - Tester, thermometer, pressure gauge, etc.
- 2) Confirmation points before check
 - a) The following operations are normal.
 1. Compressor does not operate.
 - Is not 3-minutes delay (3 minutes after compressor OFF)?
 - Does not thermostat turn off?
 - Does not timer operate during fan operation?
 - Is not outside high-temperature operation controlled in heating operation?
 2. Indoor fan does not rotate.
 - Does not cool air discharge preventive control work in heating operation?
- 3) Outdoor fan does not rotate or air volume changes.
 - Does not high-temperature release operation control work in heating operation?
 - Does not outside low-temperature operation control work in cooling operation?
 - Is not defrost operation performed?
- 4) ON/OFF operation cannot be performed from remote controller.
 - Is not forced operation performed?
 - Is not the control operation performed from outside/remote side?
 - Is not automatic address being set up?
 - a) Did you return the cabling to the initial positions?
 - b) Are connecting cables between indoor unit and receiving unit correct?

2. Troubleshooting procedure

(When the power is turned on at the first time or when indoor unit address setting is changed, the operation cannot be performed for maximum approx. 5 minutes after power-ON.)

When a trouble occurred, check the parts along with the following procedure.

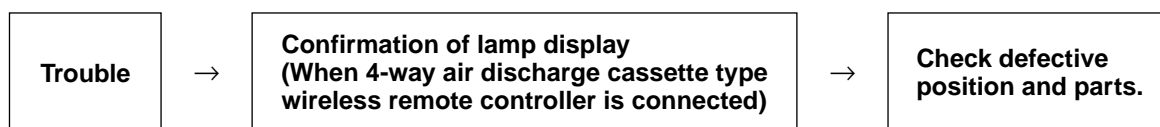

1) Outline of judgment

The primary judgment to check where a trouble occurred in indoor unit or outdoor unit is performed with the following method.

Method to judge the erroneous position by flashing indication on the display part of indoor unit (sensors of the receiving unit)

The indoor unit monitors operating status of the air conditioner, and the blocked contents of self-diagnosis are displayed restricted to the following cases if a protective circuit works.

9-2. Check Code List

Error mode detected by indoor and outdoor units

◎ : Flash, ○ : Go on, ● : Go off

Wireless sensor lamp display			Wired remote controller	Diagnostic function			Judgment and measures
Operation	Timer	Ready	Check code	Cause of operation	Status of air conditioner	Condition	
◎	●	●	E03	No communication from remote controller (including wireless) and communication adapters	Stop (Automatic reset)	Displayed when error is detected	1. Check cables of remote controller and communication adapters. • Handy remote controller LCD display OFF (Disconnection) • Central remote controller [97] check code
●	●	◎	E04	The serial signal is not output from outdoor unit to indoor unit. • Miscabling of inter-unit cables • Defective serial sensing circuit on outdoor P.C. board • Defective serial receiving circuit on indoor P.C. board	Stop (Automatic reset)	Displayed when error is detected	1. Outdoor unit does not completely operate. • Inter-unit cable check, correction of miscabling, case thermo operation • Outdoor P.C. board check, P.C. board cables check 2. In normal operation P.C. board (Indoor receiving/Outdoor sending) check
◎	●	●	E08	Duplicated indoor unit addresses	Stop	Displayed when error is detected	1. Check whether there is modification of remote controller connection (Group/Individual) or not after power has been turned on (finish of group configuration/address check). * If group configuration and address are not normal when the power has been turned on, the mode automatically shifts to address setup mode. (Resetting of address)
◎	●	●	E10	Communication error between indoor MCU • Communication error between fan driving MCU and main MCU	Stop (Automatic reset)	Displayed when error is detected	1. Check cables of remote controller. 2. Check power cables of indoor unit. 3. Check indoor P.C. board.
◎	●	●	E18	Regular communication error between master and sub indoor units or between main and sub indoor units	Stop (Automatic reset)	Displayed when error is detected	1. Check cables of remote controller. 2. Check indoor power cable. 3. Check indoor P.C. board.
◎	◎	●	F01	Coming-off, disconnection or short of indoor heat exchanger sensor (TCJ)	Stop (Automatic reset)	Displayed when error is detected	1. Check indoor heat exchanger temperature sensor (TCJ). 2. Check indoor P.C. board.
◎	◎	●	F02	Coming-off, disconnection or short of indoor heat exchanger sensor (TC)	Stop (Automatic reset)	Displayed when error is detected	1. Check indoor heat exchanger temperature sensor (TC). 2. Check indoor P.C. board.
◎	◎	○	F04	Coming-off, disconnection or short of outdoor temperature sensor (TD)	Stop	Displayed when error is detected	1. Check outdoor temperature sensor (TD). 2. Check outdoor CDB P.C. board.
◎	◎	○	F06	Coming-off, disconnection or short of outdoor temperature sensor (TE/TS)	Stop	Displayed when error is detected	1. Check outdoor temperature sensor (TE/TS). 2. Check outdoor CDB P.C. board.
◎	◎	○	F08	Coming-off, disconnection or short of outdoor temperature sensor (TO)	Operation continues.	Displayed when error is detected	1. Check outdoor temperature sensor (TO). 2. Check outdoor CDB P.C. board.
◎	◎	●	F10	Coming-off, disconnection or short of indoor heat exchanger sensor (TA)	Stop (Automatic reset)	Displayed when error is detected	1. Check indoor heat exchanger temperature sensor (TA). 2. Check indoor P.C. board.
◎	◎	●	F29	Indoor EEPROM error • EEPROM access error	Stop (Automatic reset)	Displayed when error is detected	1. Check indoor EEPROM. (including socket insertion) 2. Check indoor P.C. board.
◎	●	●	H01	Breakdown of compressor • Displayed when error is detected	Stop	Displayed when error is detected	1. Check power voltage. AC200V ±20V 2. Overload operation of refrigerating cycle 3. Check current detection circuit at AC side.
●	◎	●	H02	Compressor does not rotate. • Over-current protective circuit operates after specified time passed when compressor had been activated.	Stop	Displayed when error is detected	1. Trouble of compressor (Compressor lock, etc.) : Replace compressor. 2. Defective cabling of compressor (Phase missing) 3. Phase-missing operation of power supply (3-phase model)
●	◎	●	H03	Current detection circuit error • Current value at AC side is high even during compressor-OFF. • Phase of power supply is missed.	Stop	Displayed when error is detected	1. Compressor immediately stops even if restarted. : Check IPDU. 2. Phase-missing operation of power supply Check 3-phase power voltage and cables.
◎	●	◎	L03	Duplicated indoor master units	Stop	Displayed when error is detected	1. Check whether there is modification of remote controller connection (Group/Individual) or not after power has been turned on (finish of group configuration/address check). * If group configuration and address are not normal when the power has been turned on, the mode automatically shifts to address setup mode. (Resetting of address)
◎	●	◎	L07	There is group line in individual indoor units.	Stop	Displayed when error is detected	
◎	●	◎	L08	Unsetting of indoor group address	Stop	Displayed when error is detected	

◎ : Flash, ○ : Go on, ● : Go off

Wireless sensor lamp display			Wired remote controller	Diagnostic function			Judgment and measures
Operation	Timer	Ready	Check code	Cause of operation	Status of air conditioner	Condition	
◎	●	◎	L09	Unset indoor capacity	Stop	Displayed when error is detected	1. Set the indoor capacity. (DN=l1)
●	◎	●	L29	Outdoor unit and other errors • Communication error between CDB and IPDU (Coming-off of connector) • Heat sink temperature error (Detection of temperature over specified value)	Stop	Displayed when error is detected	1. Check cables of CDB and IPDU. 2. Abnormal overload operation of refrigerating cycle
◎	○	◎	L30	Abnormal outside interlock input	Stop	Displayed when error is detected	1. Check outside devices. 2. Check indoor P.C. board.
◎	○	◎	L31	Phase detection protective circuit operates. (Normal models)	Operation continues. (Compressor stops.)	Displayed when error is detected	1. Check power phase order (Reversed phase)/phase missing. 2. Check outdoor P.C. board.
No check code is displayed.				Fan motor thermal protection	Stop	Displayed when error is detected	1. Check thermal relay of fan motor. 2. Check indoor P.C. board.
◎	●	◎	P03	Discharge temperature error • Discharge temperature over specified value was detected.	Stop	Displayed when error is detected	1. Check refrigerating cycle. (Gas leak) 2. Trouble of PMV 3. Check Td sensor.
◎	●	◎	P04	High-pressure protection error by TE sensor (Temperature over specified value was detected.)	Stop	Displayed when error is detected	1. Overload operation of refrigerating cycle 2. Check outdoor temperature sensor (TE). 3. Check outdoor CDB P.C. board.
●	◎	◎	P10	Float switch operation • Disconnection, coming-off, defective float switch contactor of float circuit	Stop	Displayed when error is detected	1. Defect of drain pump 2. Clogging of drain pump 3. Check float switch. 4. Check indoor P.C. board.
●	◎	◎	P12	Indoor DC fan error	Stop	Displayed when error is detected	1. Defective detection of position 2. Over-current protective circuit of indoor fan driving unit operates. 3. Lock of indoor fan 4. Check indoor P.C. board.
◎	●	◎	P19	Error in 4-way valve system • Indoor heat exchanger temperature lowered after start of heating operation.	Stop (Automatic reset)	Displayed when error is detected	1. Check 4-way valve. 2. Check indoor heat exchanger (TC/TCJ) sensor. 3. Check indoor P.C. board.
◎	●	◎	P22	Outdoor DC fan error	Stop	Displayed when error is detected	1. Defective detection of position 2. Over-current protective circuit of outdoor fan driving unit operates. 3. Lock of outdoor fan 4. Check outdoor CDB P.C. board.
◎	●	◎	P26	Inverter over-current protective circuit operates. (For a short time) Short voltage of main circuit operates.	Stop	Displayed when error is detected	1. Inverter immediately stops even if restarted. : Compressor motor rare short 2. Check IPDU. : Cabling error
◎	●	◎	P29	IPDU position detection circuit error	Stop	Displayed when error is detected	1. Position detection circuit operates even if operating compressor by removing 3P connector. : Replace IPDU.
◎	●	◎	P31	Own unit stops while warning is output to other indoor units.	Stop (Sub unit) (Automatic reset)	Displayed when error is detected	1. Judge sub unit while master unit is in [E03], [L03], [L07], [L08]. 2. Check indoor P.C. board.

For an error mode detected in outdoor unit, the fan operates because sub unit of a group operation does not communicate with the outdoor unit.

Error mode detected by remote controller

⊙ : Flash, ○ : Go on, ● : Go off

Wireless sensor lamp display			Wired remote controller	Diagnostic function			Judgment and measures
Operation	Timer	Ready	Check code	Cause of operation	Status of air conditioner	Condition	
—	—	—	No check code is displayed. (Remote controller does not operate.)	No communication with master indoor unit • Remote controller cable is not correctly connected. • Power of indoor unit is not turned on. • Automatic address cannot be completed.	Stop	—	Remote controller power error, Defective indoor EEPROM 1. Check remote controller inter-unit cables. 2. Check remote controller. 3. Check indoor power cables. 4. Check indoor P.C. board. 5. Check indoor EEPROM. (including socket insertion) : Phenomenon of automatic address repetition occurred.
⊙	●	●	E01	No communication with indoor master unit • Disconnection of inter-unit cable between remote controller and master indoor unit (Detected at remote controller side)	Stop (Automatic restart) * When there is center, operation continues.	Displayed when error is detected	Signal receiving of remote controller is defective. 1. Check remote controller inter-unit cables. 2. Check remote controller. 3. Check indoor power cables. 4. Check indoor P.C. board.
⊙	●	●	E02	Signal sending error to indoor unit (Detected at remote controller side)	Stop (Automatic restart) * When there is center, operation continues.	Displayed when error is detected	Signal sending of remote controller is defective. 1. Check sending circuit inside of remote controller. : Replace remote controller.
⊙	●	●	E09	Multiple master remote controllers are recognized. (Detected at remote controller side)	Stop (Sub unit continues operation.)	Displayed when error is detected	1. Check there are multiple master units for 2 remote controllers (including wireless). : Master unit is one and others are sub units.
⊙	○	⊙	L20	Duplicated indoor central addresses on communication of central control system (Detected by central controller side)	Stop (Automatic restart)	Displayed when error is detected	1. Check address setup of central control system network. (DN = 03)

Error mode detected by central remote controller

⊙ : Flash, ○ : Go on, ● : Go off

Wireless sensor lamp display			Wired remote controller	Diagnostic function			Judgment and measures
Operation	Timer	Ready	Check code	Cause of operation	Status of air conditioner	Condition	
—	—	—	C05	Sending error central remote controller	Operation continues	Displayed when error is detected	1. Check communication line/miscabling/ Check power of indoor unit. 2. Check communication. (U3, U4 terminals) 3. Check network adapter P.C. board.
—	—	—	C06	Receiving error in central remote controller	Operation continues	Displayed when error is detected	4. Check central controller (such as central control remote controller, etc.). 5. Terminal resistance check (connection interface SW01)
—	—	—	P30	Differs according to error contents of unit with occurrence of alarm.	Continuation/Stop (Based on a case)	Displayed when error is detected	Check the check code of corresponding unit by remote controller

9-3. Error Mode Detected by LED on Outdoor P.C. Board

RAV-SP562AT-E only

<SW801: LED display in bit 1, bit 2 OFF>

- When multiple errors are detected, the latest error is displayed.
- When LED display is ○ (Go on), there is the main cause of trouble on the objective part of control at CDB side and the unit stops.
- When LED display is ◎ (Flash), there is the main cause of trouble on the objective part of control at IPDU side and the unit stops.
- When case thermostat operates, the communication is interrupted on the serial circuit.

If continuing the case thermostat operation, a serial communication error occurs because serial sending to the indoor unit is interrupted.

	No.	Item	Check code Type A	LED display			
				D800 (Red)	D801 (Yellow)	D802 (Yellow)	D803 (Yellow)
CDB side	1	TE sensor error	F06	○	●	●	●
	2	TD sensor error	F04	○	○	●	●
	3	TS sensor error	F06	●	●	○	●
	4	TO sensor error	F08	●	○	●	●
	5	Discharge temp. error	P03	●	○	○	●
	6	DC outdoor fan error	P22	○	○	○	●
	7	Communication error between IPDU (Abnormal stop)	L29	○	●	●	○
	8	High-pressure release operation	P04	●	○	●	○
	9	EEPROM error	—	○	○	●	○
	10	Communication error between IPDU (No abnormal stop)	—	●	●	○	○
IPDU side	11	IGBT short-circuit protection	P26	◎	●	●	●
	12	Detection circuit error	P29	●	◎	●	●
	13	Current sensor error	H03	◎	◎	●	●
	14	Comp. lock error	H02	●	●	◎	●
	15	Comp. breakdown	H01	◎	●	◎	●

○ : Go on ● : Go off ◎ : Flash (5Hz)

<<Check code>>

The check codes are classified into Type A and Type B according to the used remote controller. Be sure to check the remote controller which you use.

Type A :

Neutral 2-cores type wired remote controller such as RBC-AMT31E, RBC-AMT32E, RBC-AS21E2, and wireless remote controller kit such as TCB-AX21E2

9-4. Troubleshooting Procedure for Each Check Code

9-4-1. Check Code

[E01 error]

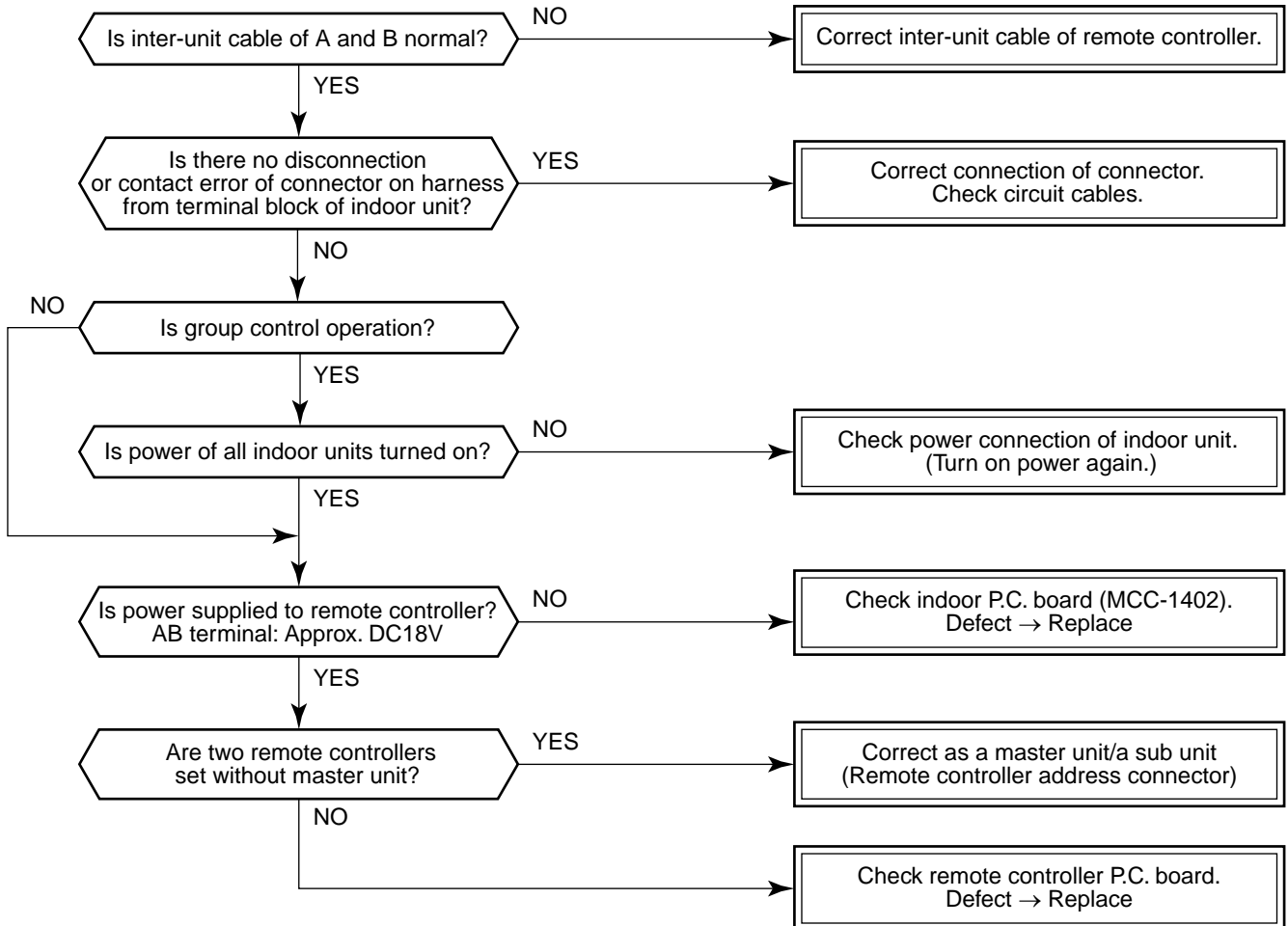

[E09 error]

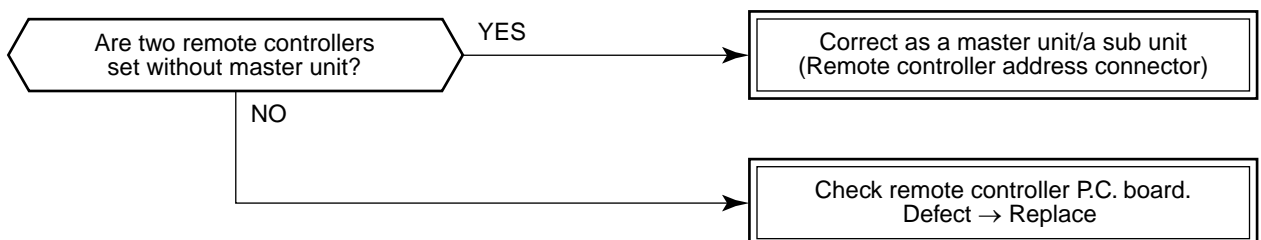

[E04 error]

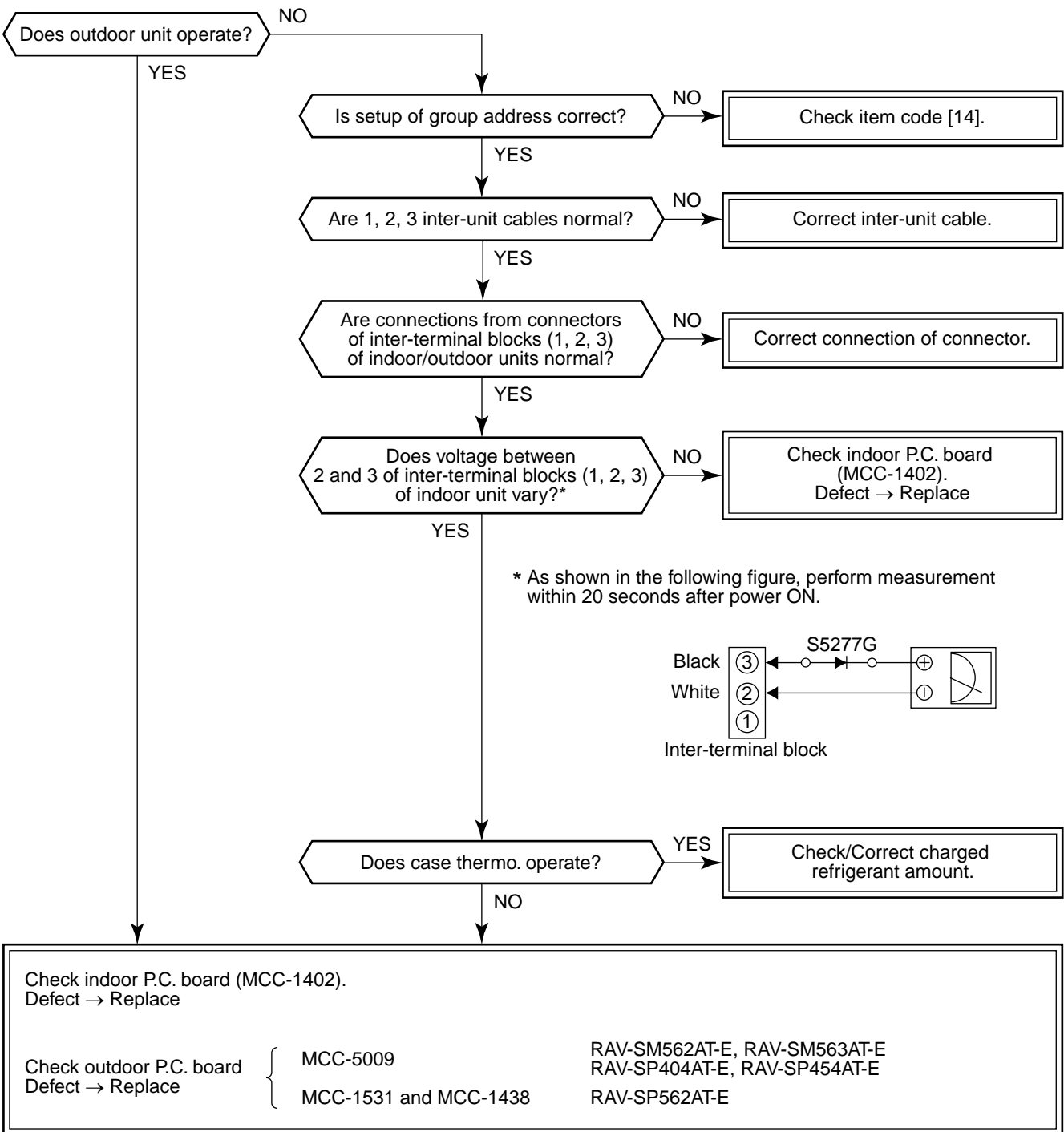

[E10 error]

Check indoor control P.C. board (MCC-1402).
Defect → Replace

[E18 error]

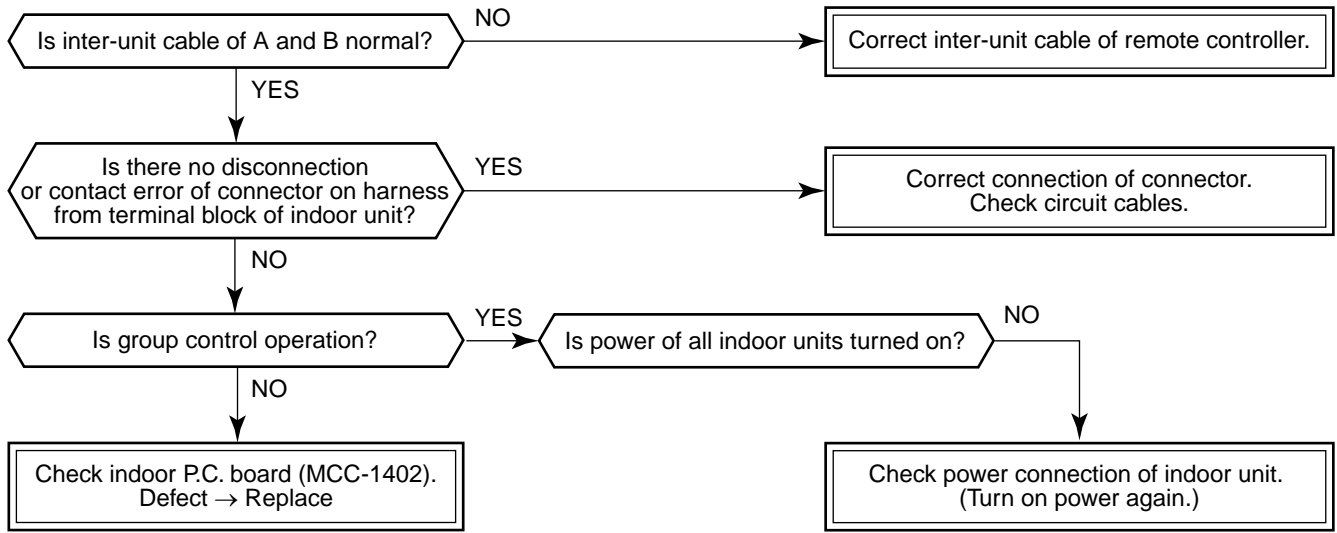

[E08, L03, L07, L08 error]

E08 : Duplicated indoor unit numbers

L03 : Two or more master units in a group control

L07 : One or more group addresses of [Individual] in a group control

L08 : Unset indoor group address (99)

If the above is detected when power has been turned on, the mode automatically enters in automatic address setup mode. (Check code is not displayed.)

However, if the above is detected during automatic address setup mode, the check code may be displayed.

[L09 error]

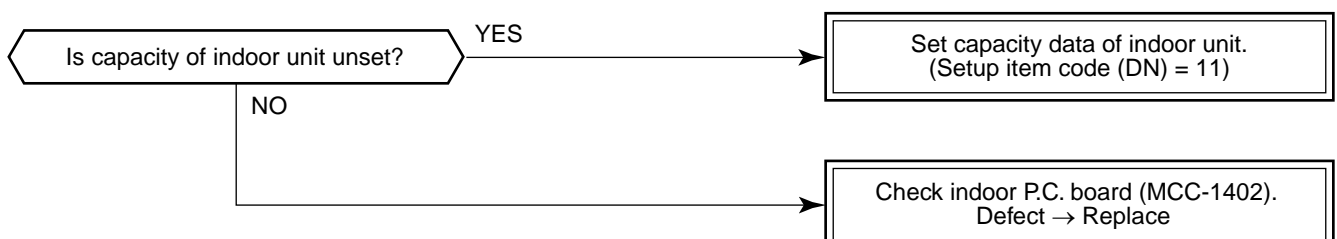

[L20 error]

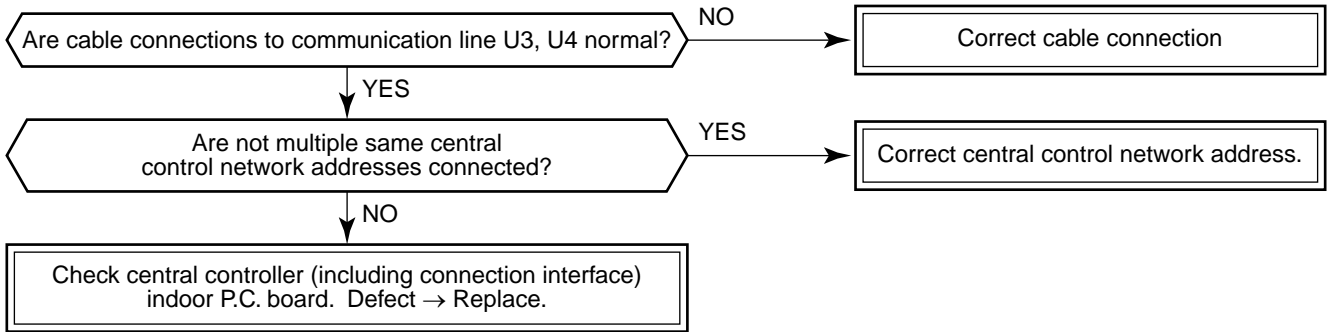

[L30 error]

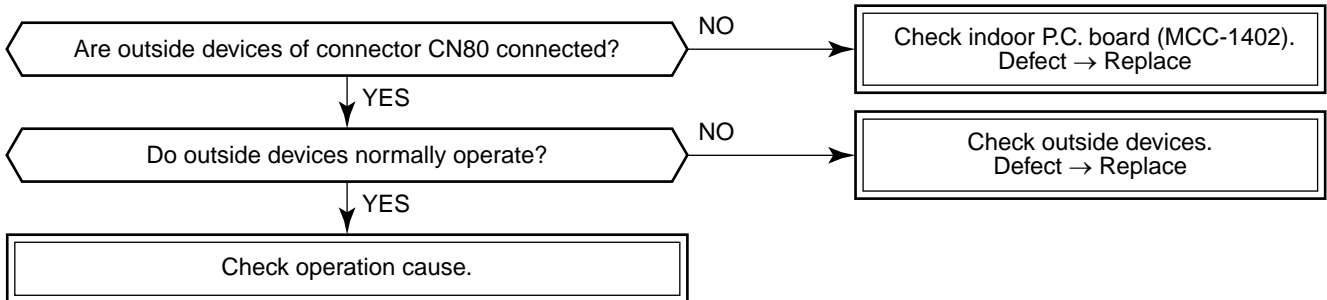

[P10 error]

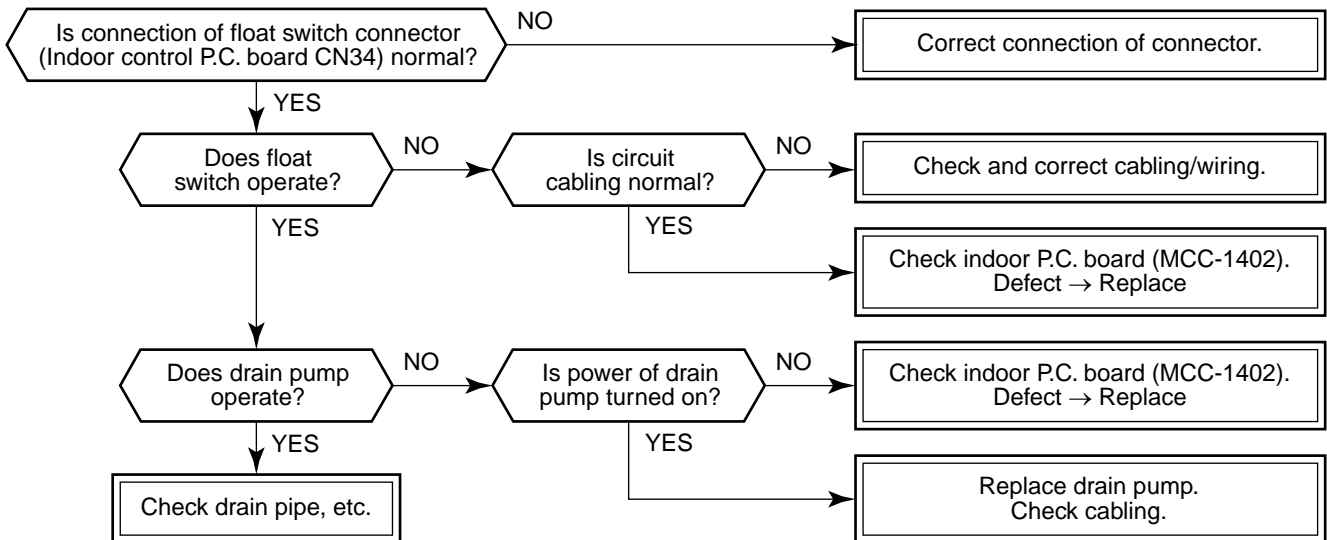

[F10 error]

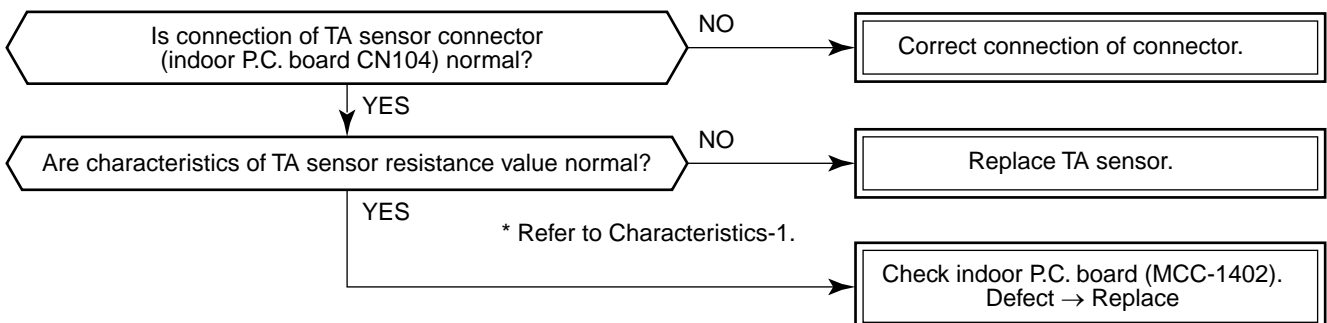

[P12 error]

<Only for 4-way air discharge cassette type models>

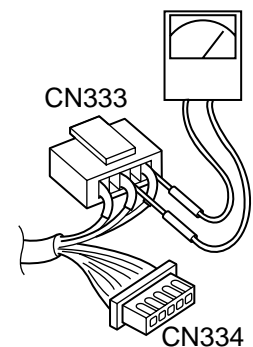
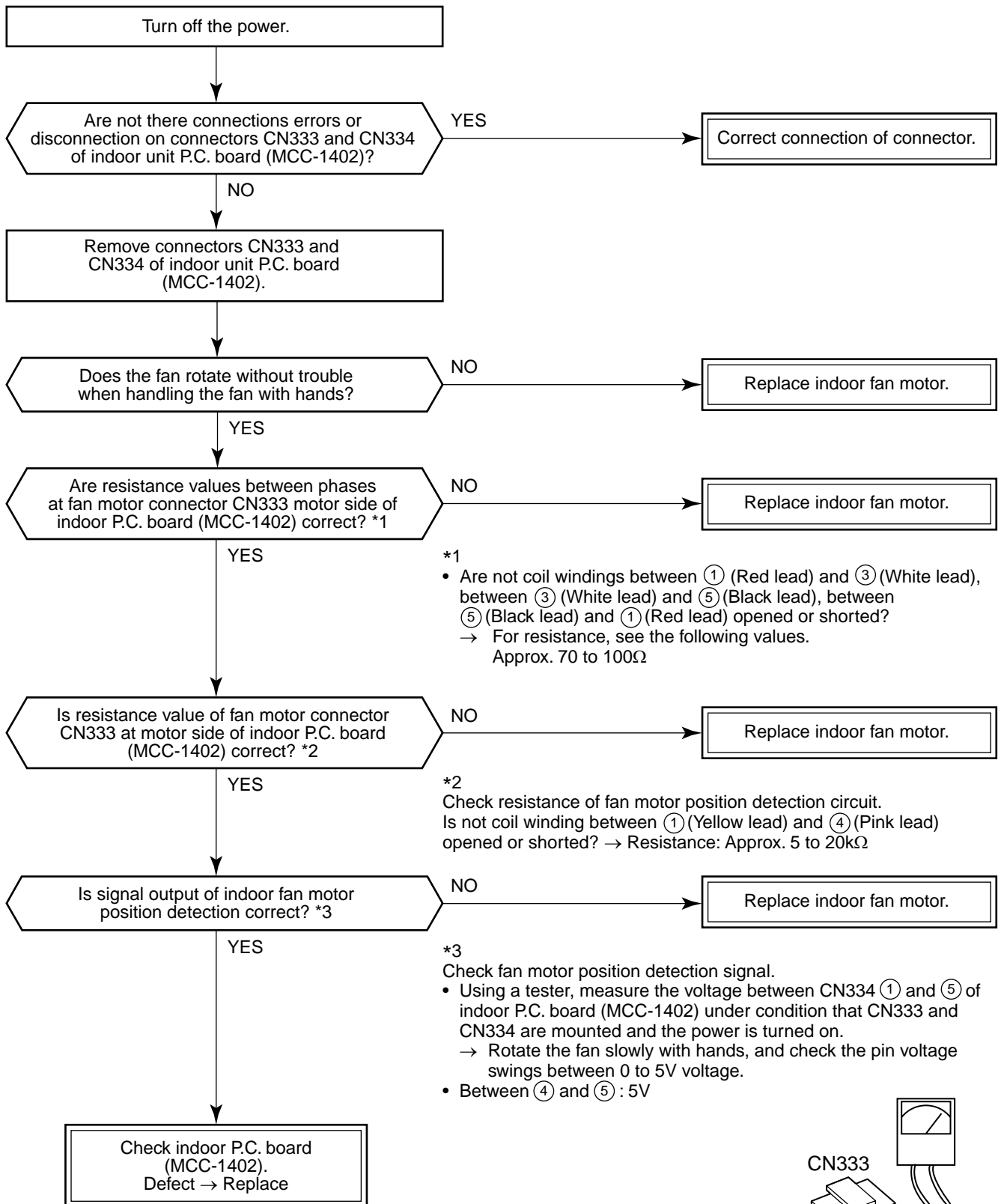

[P22 error]

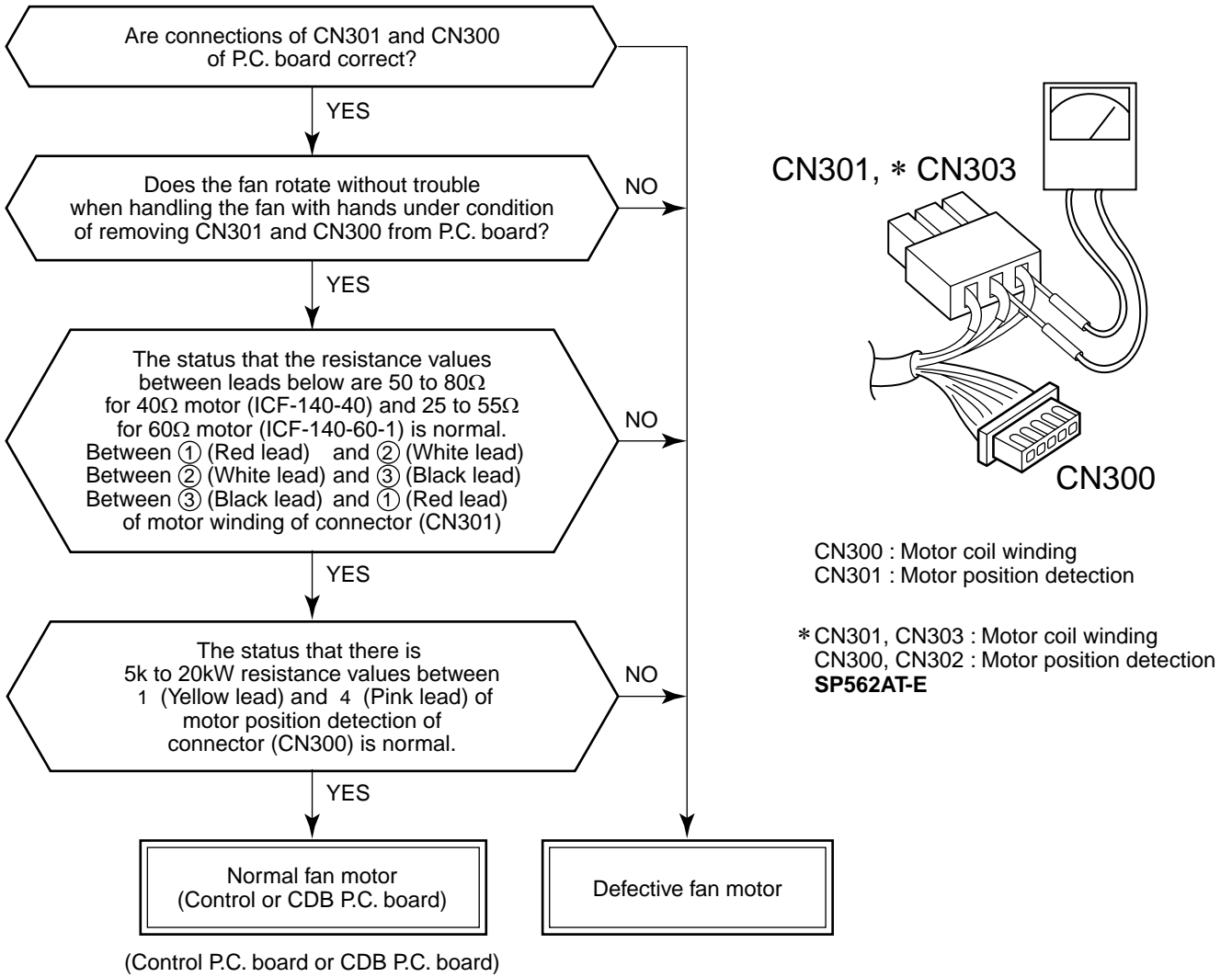

NOTE :

However, GND circuit error inside of the motor is rarely detected even if the above check is carried out. When the circuit does not become normal even if P.C. board has been replaced, replace outdoor fan motor.

	Single phase	
	RAV-SM562AT-E, SM563AT-E RAV-SP404AT-E, SP454AT-E	RAV-SP562AT-E
Objective P.C. board	Control P.C. board	CDB P.C. board
Fan motor winding	CN300	CN301
Motor position detection	CN301	CN300

[P19 error]

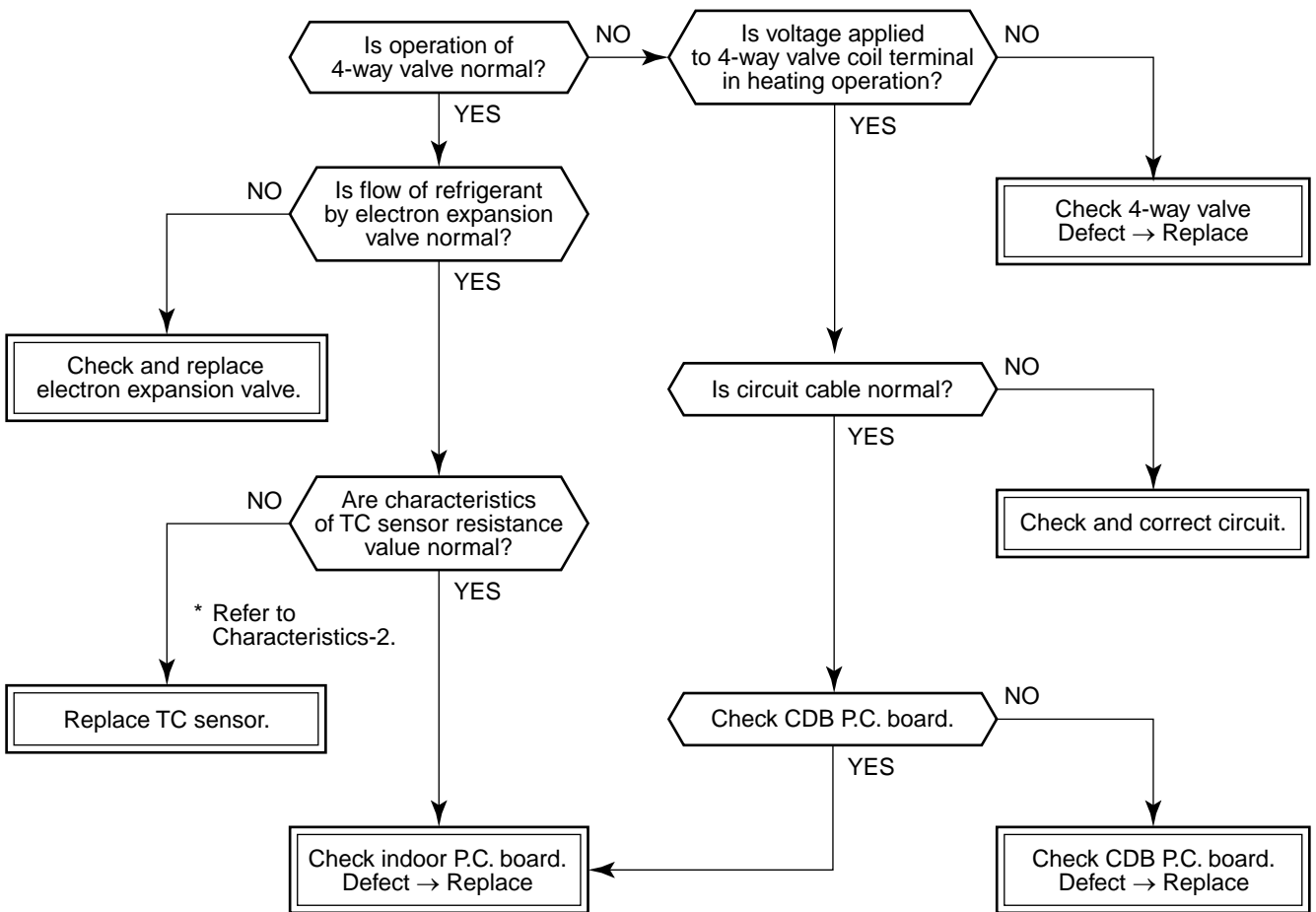

* For RAV-SM562AT-E, check control P.C. board.

- In cooling operation, if high pressure is abnormally raised, [P19 error]/[08 error] may be displayed. In this case, remove cause of pressure up and then check again referring to the item [P04 error]/[21 error].

[F02 error]

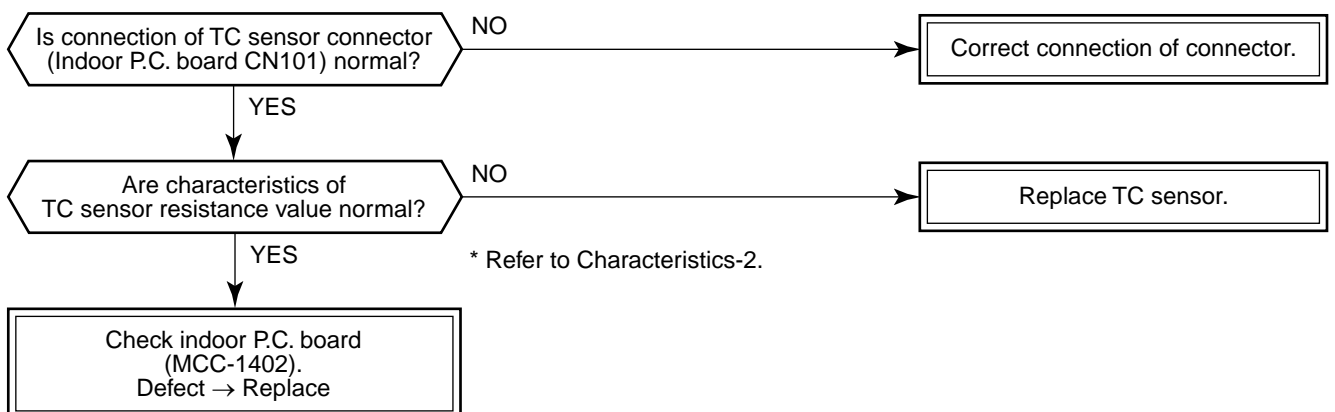

[F01 error]

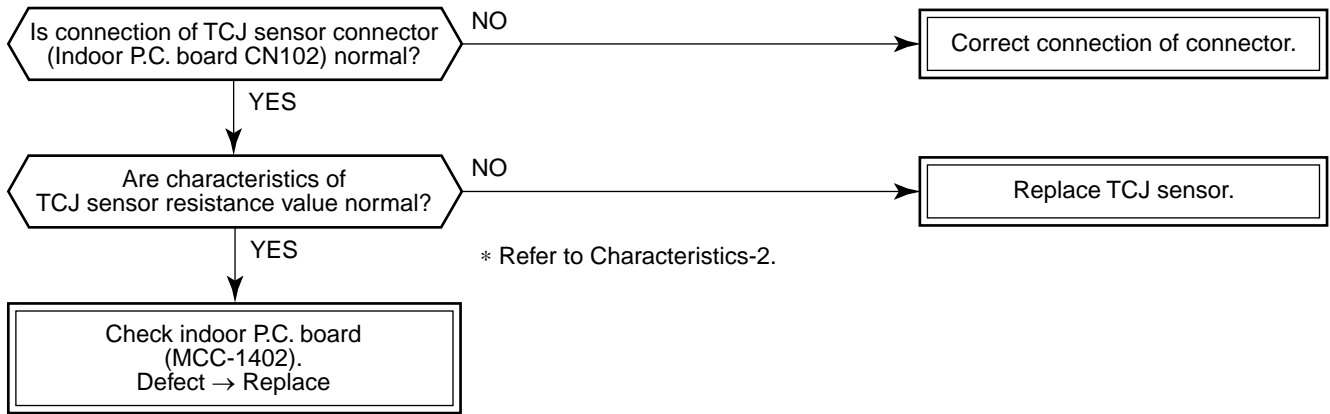

[P26 error]

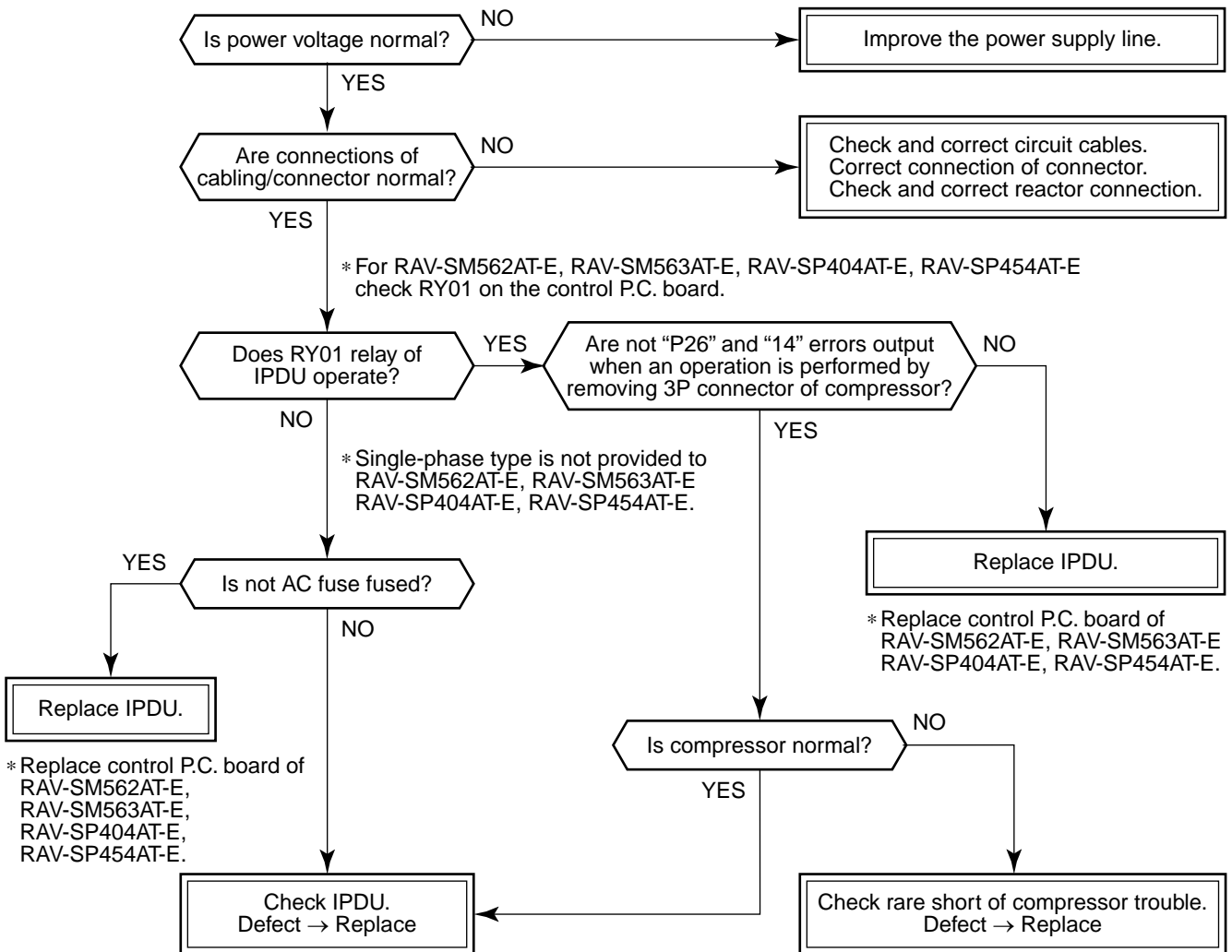

[P29 error]

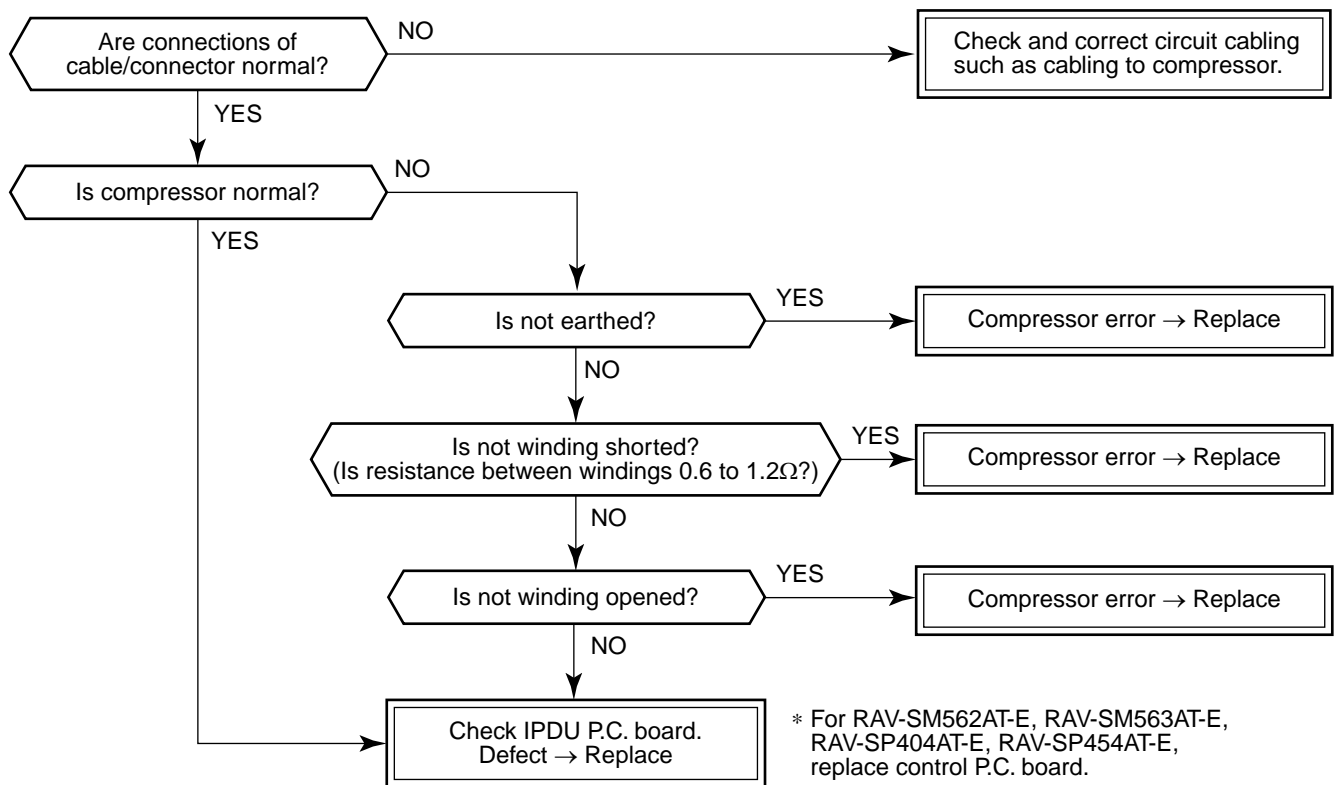

[H03 error]

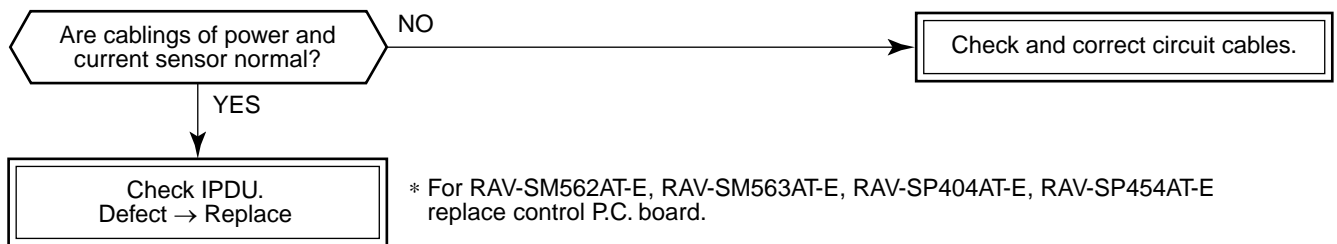

[F06 error]

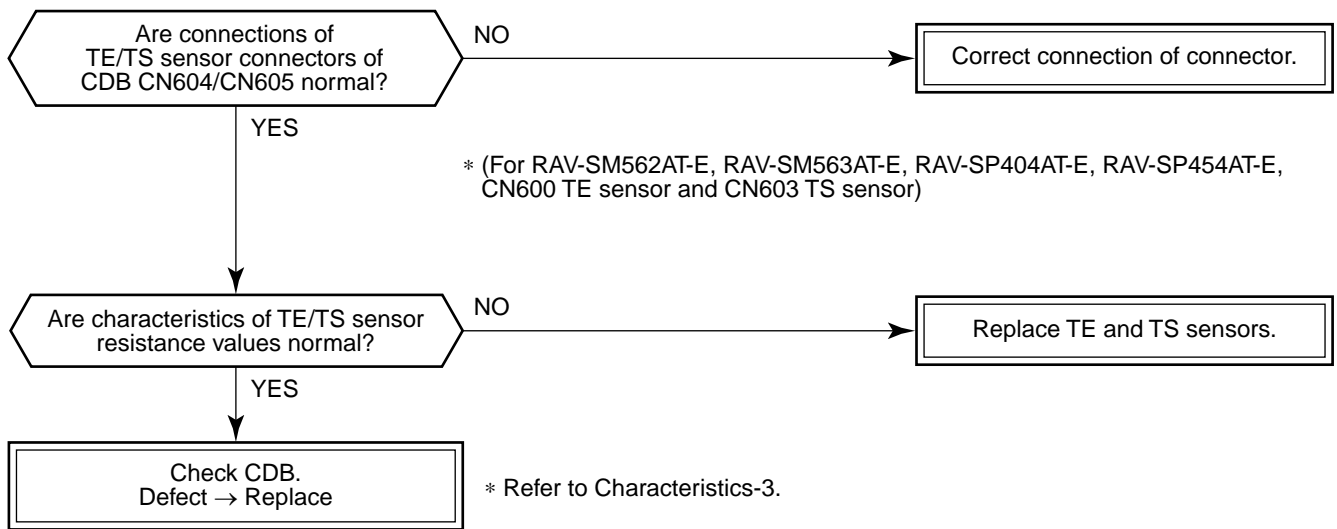

[F04 error]

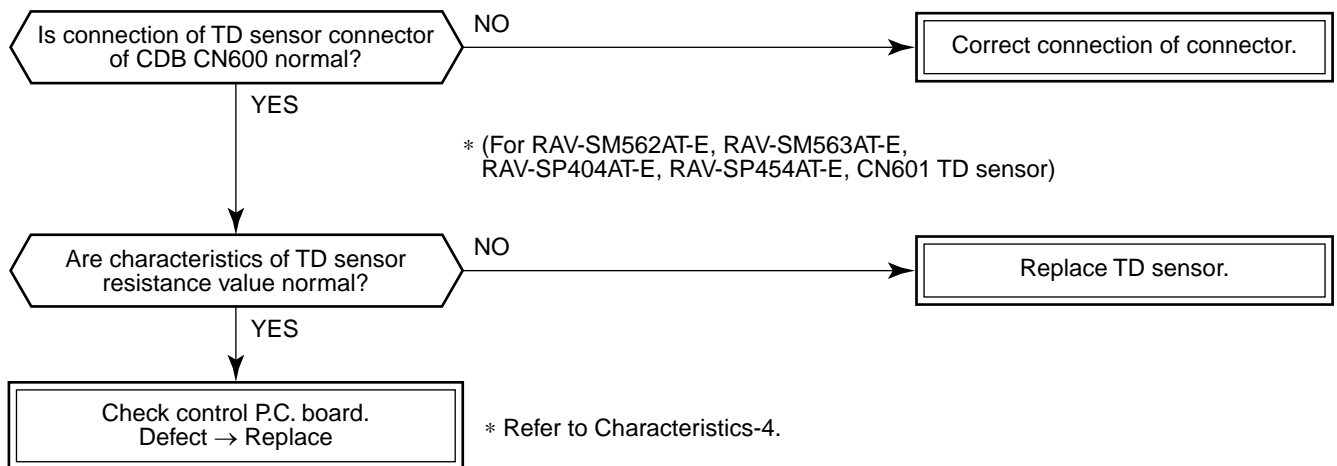

[F08 error]

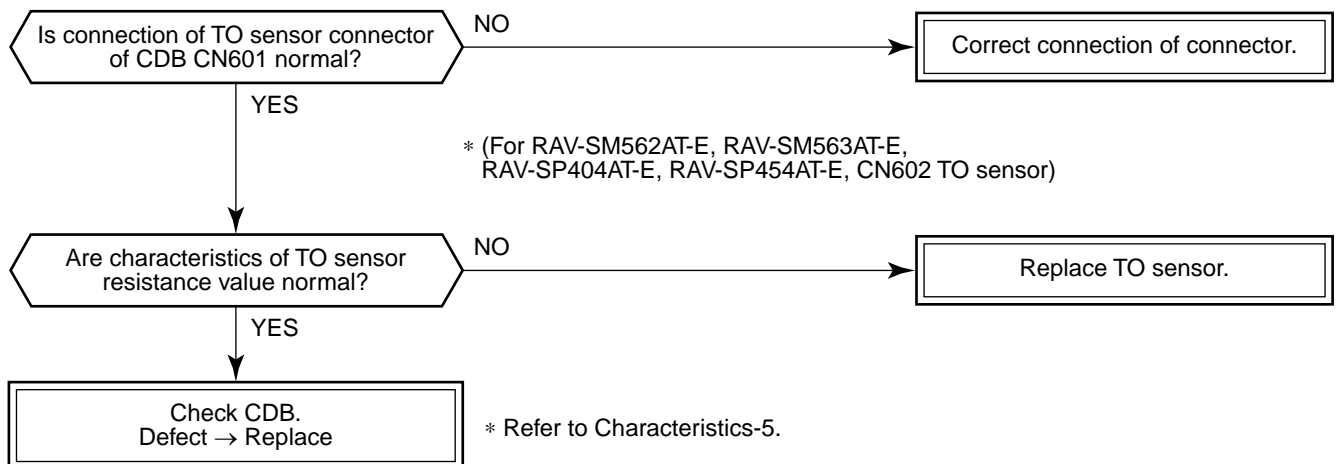

[L29 error]

In the case of SUPER DIGITAL INVERTER

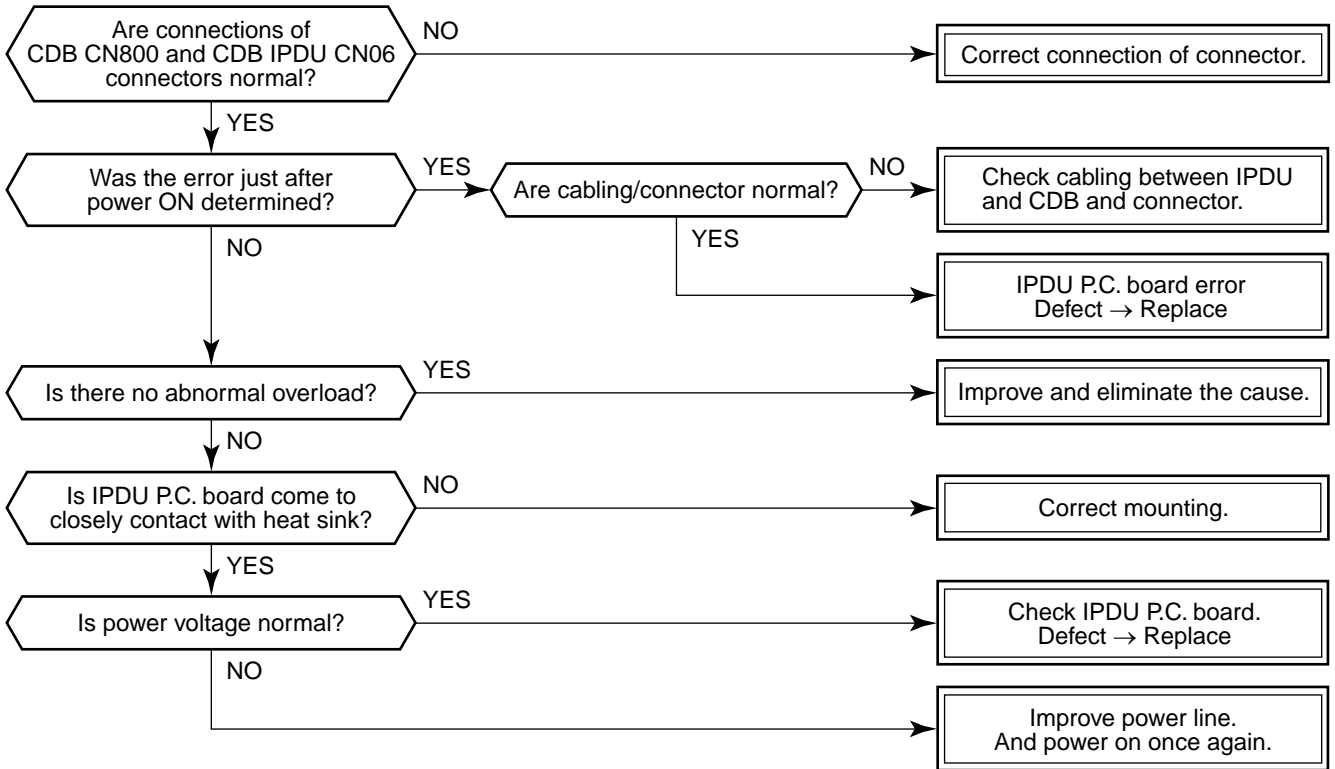

In the case of DIGITAL INVERTER



[H02 error]

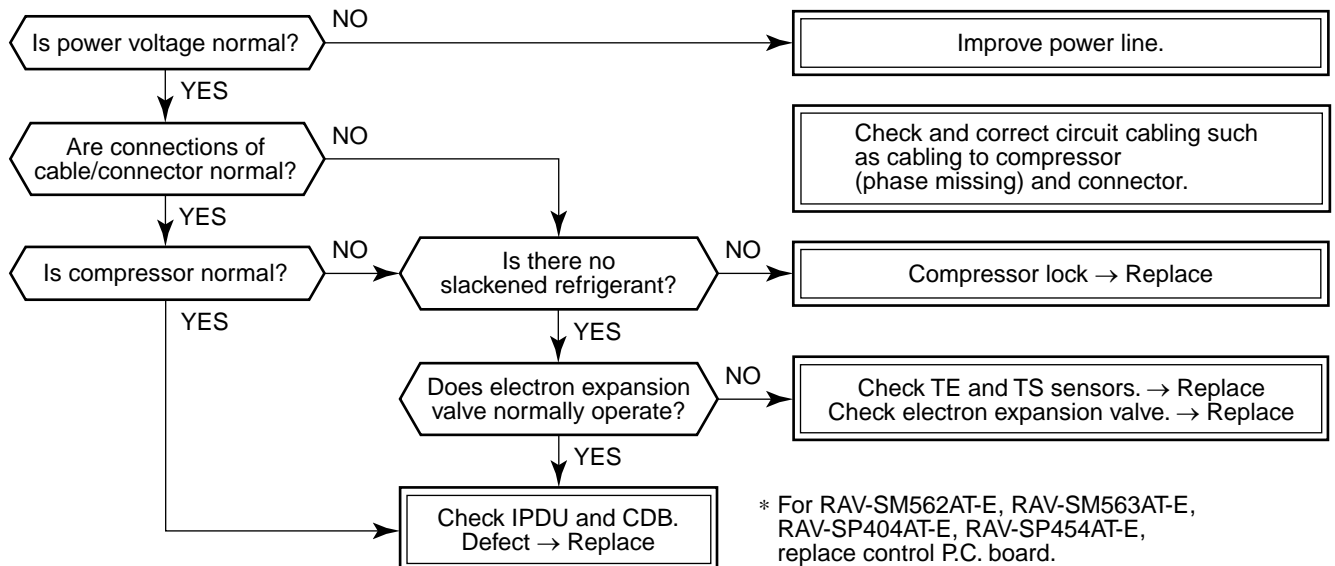

* For RAV-SM562AT-E, RAV-SM563AT-E, RAV-SP404AT-E, RAV-SP454AT-E, replace control P.C. board.

[P03 error]

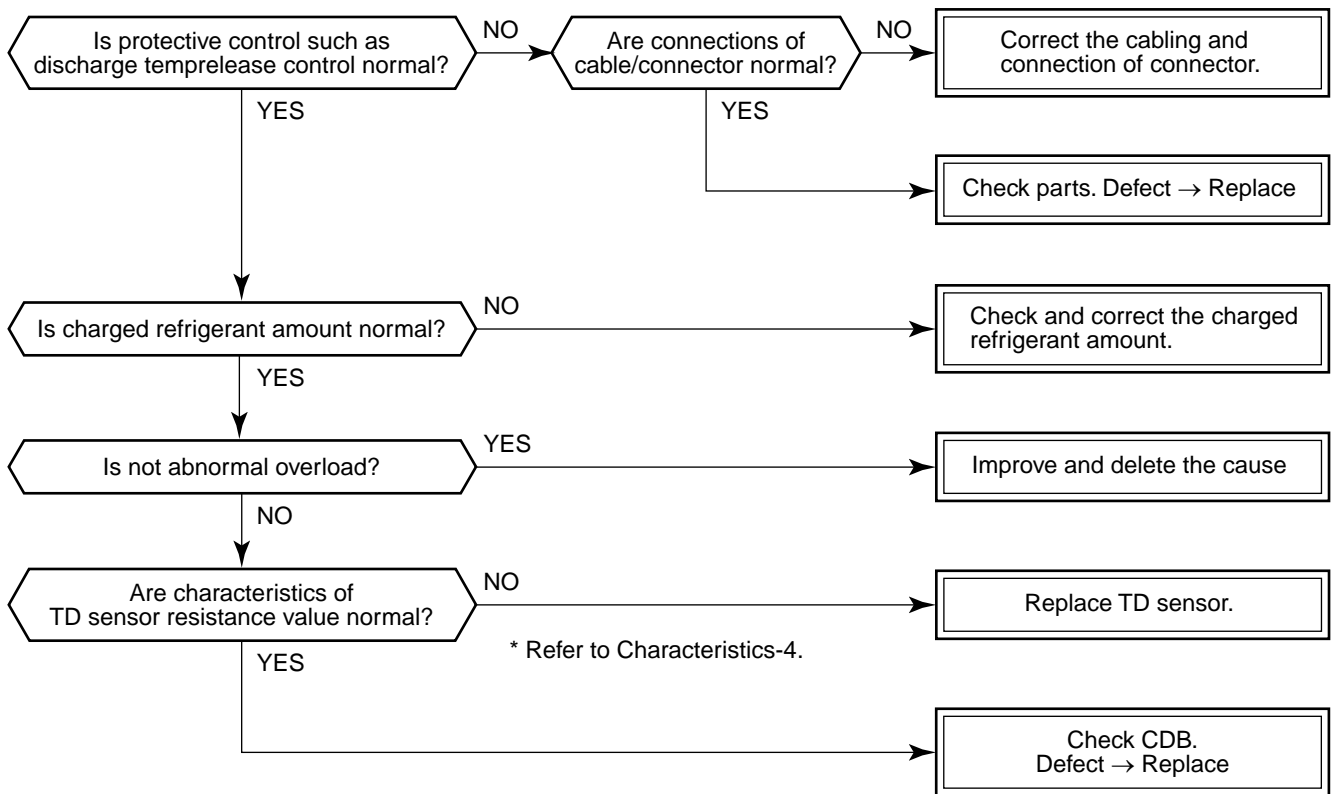

* For RAV-SM562AT-E, RAV-SM563AT-E, RAV-SP404AT-E, RAV-SP454AT-E, replace control P.C. board.

[H01 error]

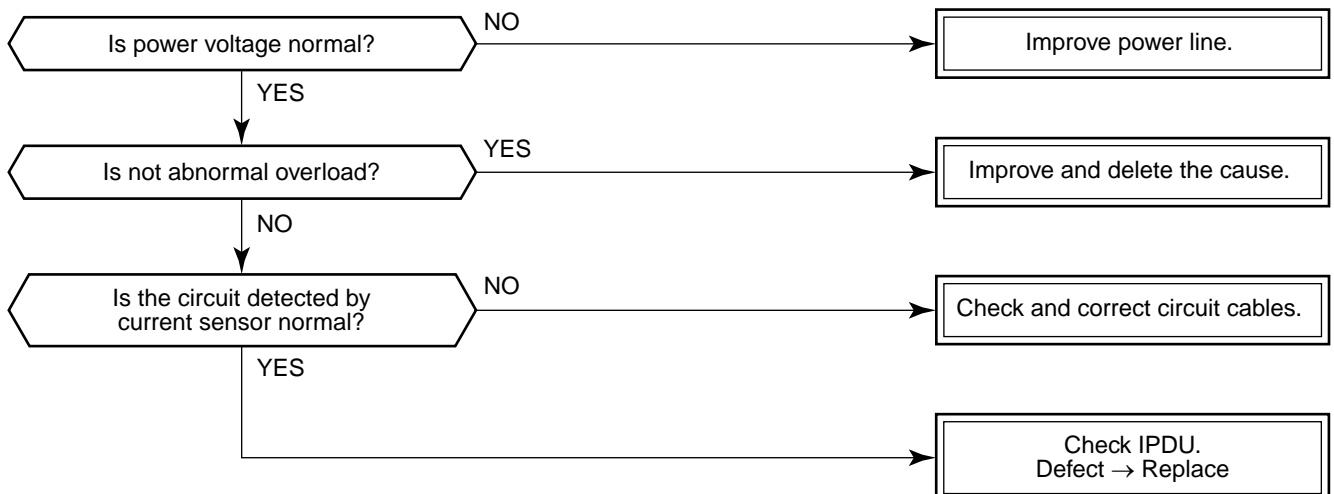

* For RAV-SM562AT-E, RAV-SM563AT-E, RAV-SP404AT-E, RAV-SP454AT-E, replace control P.C. board.

[P04 error]

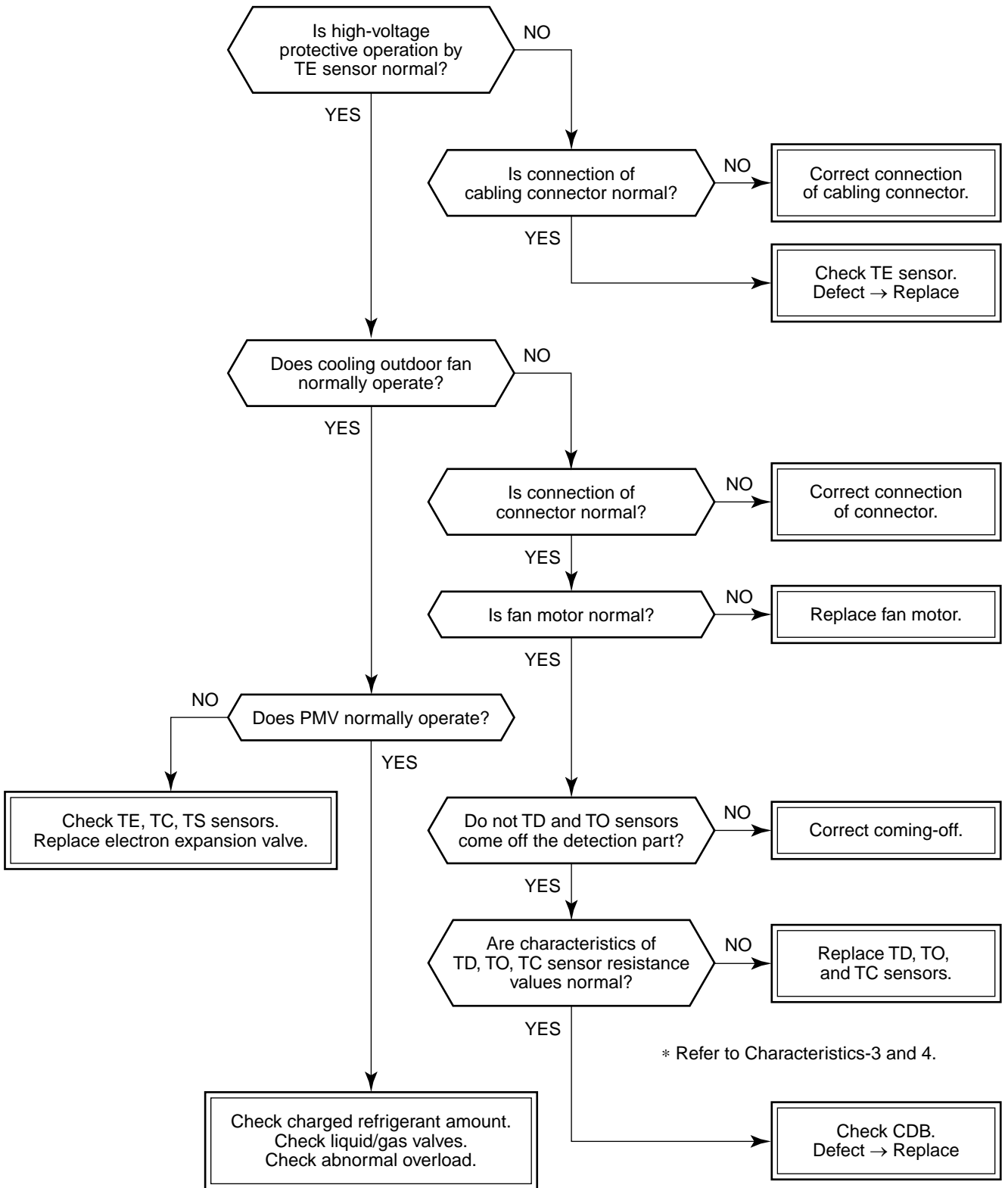

* Refer to Characteristics-3 and 4.

* For RAV-SM562AT-E, RAV-SM563AT-E, RAV-SP404AT-E, RAV-SP454AT-E, replace control P.C. board.

[C06 error] (Central controller)

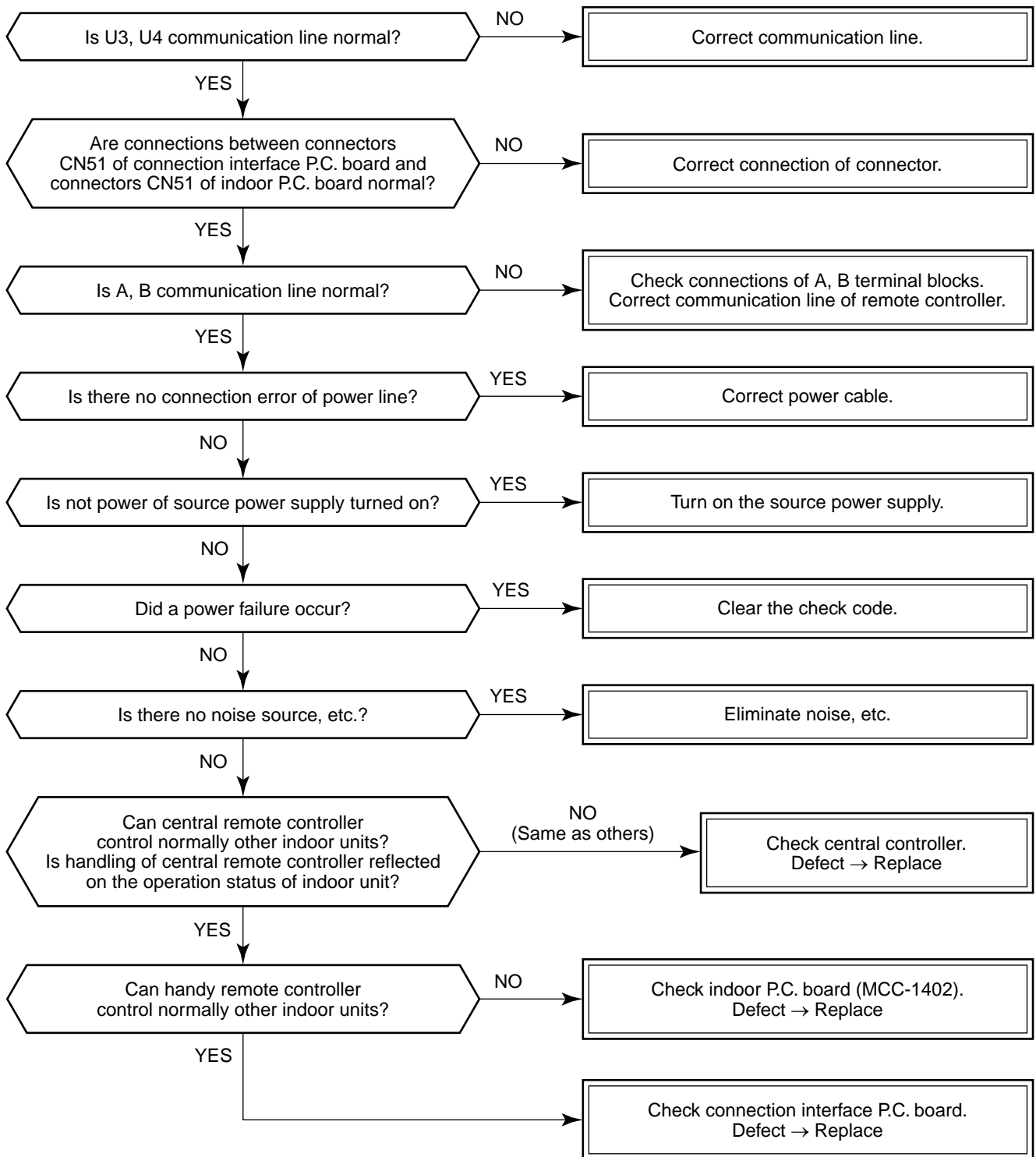

[E03 error] (Master indoor unit)

[E03 error] is detected when the indoor unit cannot receive a signal sent from the main remote controller (and central controller).

In this case, check the communication cables of the remote controllers A and B, the central control system X and Y. As communication is disabled, [E03] is not displayed on the main remote controller and the central controller. [E01] is displayed on the main remote controller and [97 error] on the central controller, respectively. If [E03] occurs during an operation, the air conditioner stops.

[F29 error] / [12 error]

[F29 error] or [12 error] indicates detection of trouble which occurred on IC10 non-volatile memory (EEPROM) on the indoor unit P.C. board during operation of the air conditioner. Replace the service P.C. board.

* If EEPROM has not been inserted when the power was turned on or if EEPROM data never be read/written, the automatic address mode is repeated. In this time, the central controller displays [97 error].

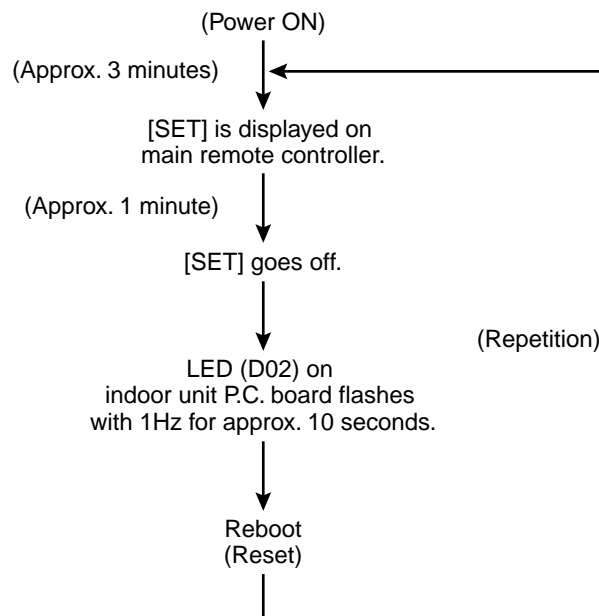

[P31 error] (Sub indoor unit)

When the master unit of a group operation has detected [E03], [L03], [L07], or [L08] error, the sub unit of the group operation detects [P31 error] and then it stops. There is no display of the check code or alarm history of the main remote controller.

(In this model, the mode enters in automatic address set mode when the master unit has detected [E03], [L03], [L07], or [L08] error.)

9-4-2. Relational Graph of Temperature Sensor Resistance Value and Temperature

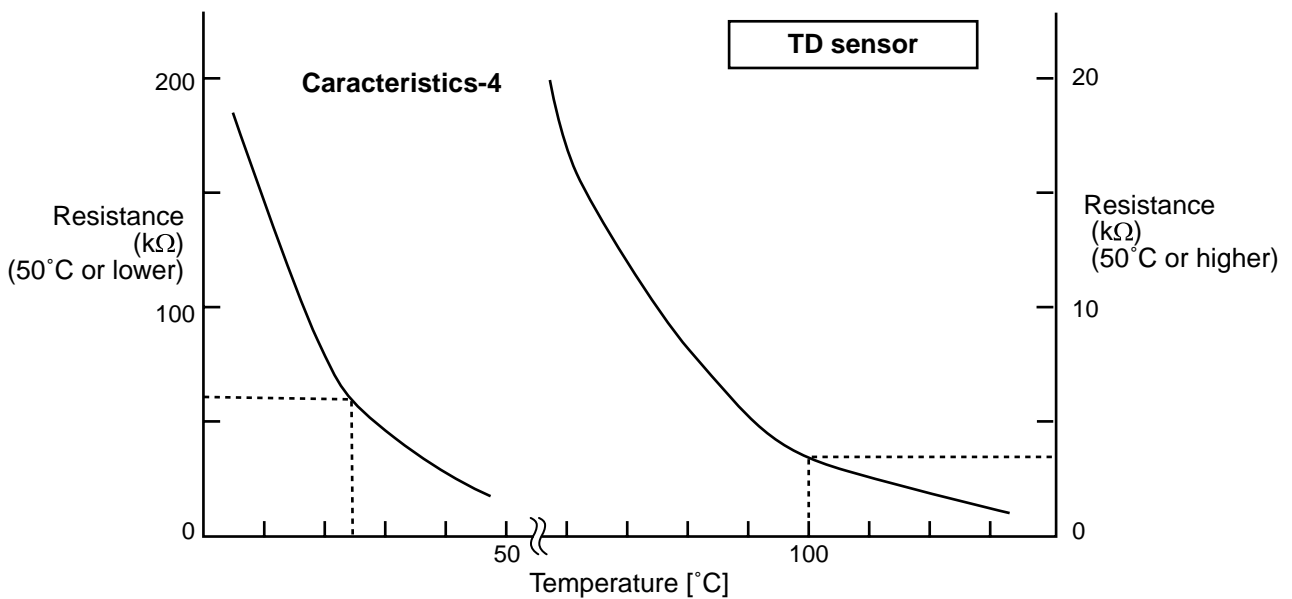
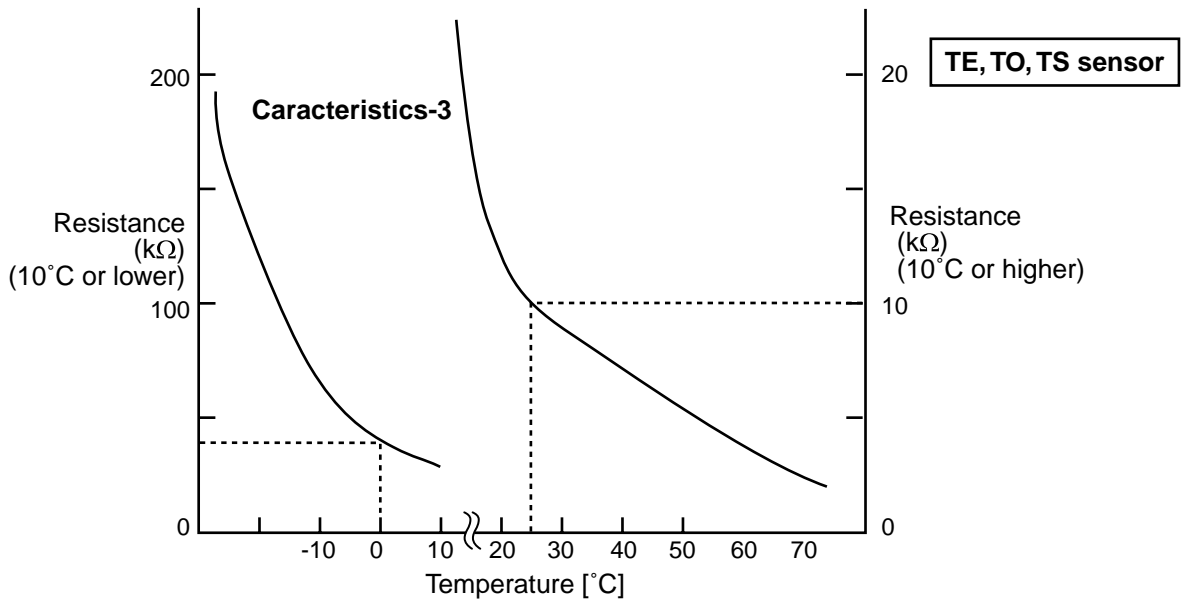
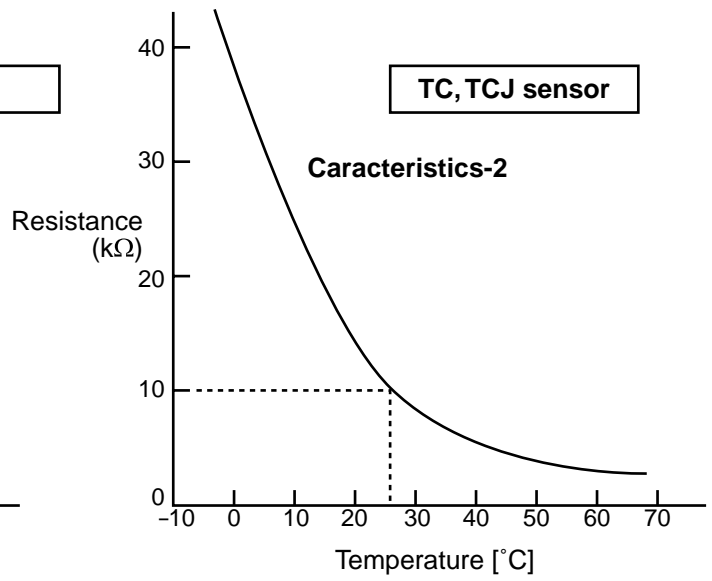
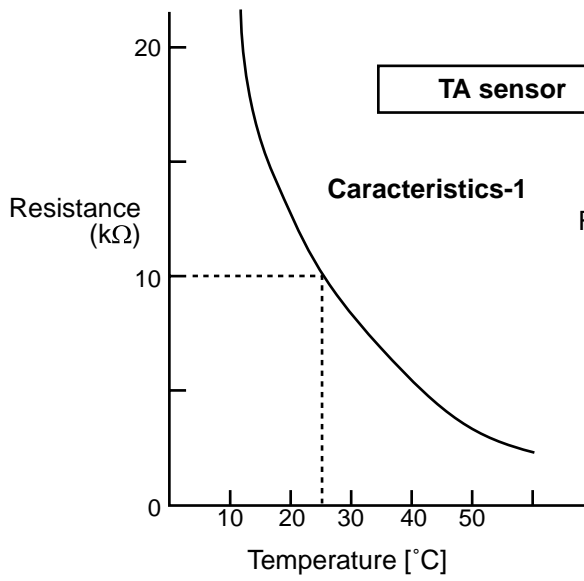

10. REPLACEMENT OF SERVICE INDOOR P.C. BOARD

[Requirement when replacing the service indoor P.C. board assembly]

In the non-volatile memory (Hereinafter said EEPROM, IC10) installed on the indoor P.C. board before replacement, the type and capacity code exclusive to the corresponding model have been stored at shipment from the factory and the important setup data such as system/indoor/group address set in (AUTO/MANUAL) mode or setting of high ceiling selection have been stored at installation time. Replace the service indoor P.C. board assembly according to the following procedure.

After replacement, check the indoor unit address and also the cycle by a test run.

<REPLACEMENT PROCEDURE>

CASE 1

Before replacement, power of the indoor unit can be turned on and the setup data can be readout from the wired remote controller.

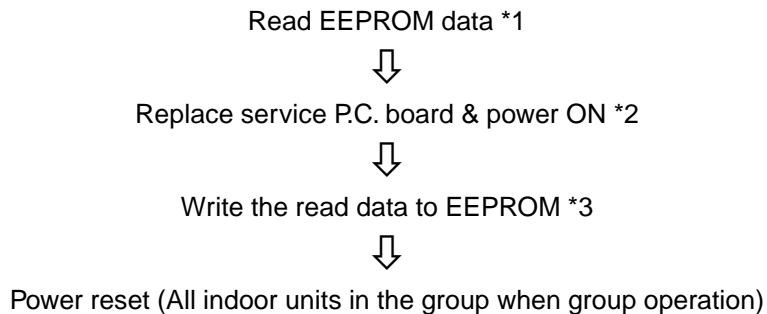

CASE 2

Before replacement the setup data can not be readout from the wired remote controller.

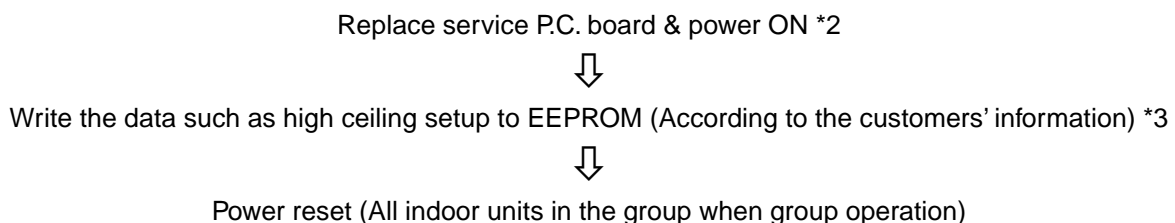

□1 Readout of the setup data from EEPROM

(Data in EEPROM contents, which have been changed at the local site, are read out together with data in EEPROM set at shipment from the factory.)

1. Push **SET**, **CL**, and **TEST** buttons of the remote controller at the same time for 4 seconds or more. **1**
(Corresponded with No. in Remote controller)
When group operation, the master indoor unit address is displayed at the first time. In this time, the item code (DN) **10** is displayed. The fan of the selected indoor unit operates and the louver starts swinging if any.
2. Every pushing **UNIT LOUVER** button, the indoor unit address in the group are displayed successively. **2**
Specify the indoor unit No. to be replaced.
3. Using the set temperature **▼** / **▲** buttons, the item code (DN) can be moved up and down one by one. **3**
4. First change the item code (DN) from **10** to **01**.
(Setting of filter sign lighting time) Make a note of the set data displayed in this time.
5. Next change the item code (DN) using the set temperature **▼** / **▲** buttons. Also make a note of the set data.
6. Repeat item 5. and make a note of the important set data as shown in the later table (Ex.).
• **01** to **FF** are provided in the item code (DN). On the way of operation, DN No. may come out.
7. After finishing making a note, push **TEST** button to return the status to usual stop status. **6**
(Approx. 1 minute is required to start handling of the remote controller.)

Minimum requirements for item code

DN	Contents
10	Type
11	Indoor unit capacity
12	Line address
13	Indoor address
14	Group address

- 1) Type and capacity of the indoor unit is necessary to set the revolutions frequency of the fan.
- 2) If Line/Indoor/Group addresses differ from those before replacement, the mode enters in automatic address setup mode and a manual resetting may be required.

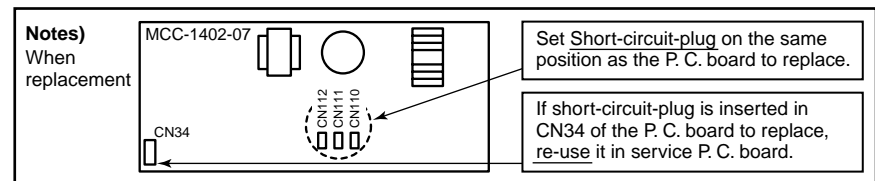

□2 Replacement of service P.C. board

1. Replace the P.C. board with a service P.C. board.
In this time, setting of jumper line (cut) or setting of (short-circuit) connecting connectors on the former P.C. board should be reflected on the service P.C. board.
 2. According to the system configuration, turn on power of the indoor unit with any method in the following items.
 - a) In case of single (individual) operation
Turn on the power supply.
 - 1) Wait for completion of automatic address setup mode (Required time: Approx. 5 minutes) and then proceed to □3.
(Line address = 1, Indoor address = 1, Group address = 0 (Individual) are automatically set.)
 - 2) Push **SET**, **CL**, and **TEST** buttons of the remote controller at the same time for 4 seconds or more (**1** operation), interrupt the automatic address setup mode, and then proceed to □3.
(Unit No. **ALL** is displayed.)
 - b) In case of group operation
Turn on power of the indoor unit of which P.C. board has been replaced with the service P.C. board with any method in the following items.
 - 1) Turn on power of the replaced indoor unit only.
(However, the remote controller is also connected. Otherwise □3 operation cannot be performed.)
Same as 1) and 2) in item a).
 - 2) Turn on power of the multiple indoor units including replaced indoor unit.
 - Only 1 system for twin, triple, double twin
 - For all units in the group
- Wait for completion of automatic address setup mode (Required time: Approx. 5 minutes) and then proceed to □3.

* The master unit of a group may change by setup of automatic address. The line address/indoor address of the replaced indoor unit are automatically set to the vacant addresses except addresses belonging to other indoor units which have not been replaced. It is recommended to make a note that the refrigerant line which includes the corresponding indoor unit and that the corresponding indoor unit is master or sub in the group control.

□3 Writing of the setup contents to EEPROM

(The contents of EEPROM installed on the service P.C. board have been set up at shipment from the factory.)

1. Push **SET**, **CL**, and **TEST** buttons of the remote controller at the same time for 4 seconds or more. **1**
(Corresponded with No. in Remote controller)
In group operation control, the master indoor unit No. is displayed at the first time. (If the automatic address setup mode is interrupted in item 2. - a) - 2) in the previous page, the unit No. **ALL** is displayed.)
In this time, the item code (DN) **10** is displayed. The fan of the selected indoor unit operates and the louver starts swinging if any.
2. Every pushing **UNIT LOUVER** button, the indoor unit numbers in the group control are displayed successively. **2**
Specify the indoor unit No. of which P.C. board has been replaced with a service P.C. board.
(When the unit No. **ALL** is displayed, this operation cannot be performed.)
3. Using the set temperature **▼** / **▲** buttons, the item code (DN) can be moved up and down one by one. **3**
4. First set a type and capacity of the indoor unit.
(Setting the type and capacity writes the data at shipment from the factory in EEPROM.)
 - 1) Set the item code (DN) to **10**. (As it is)
 - 2) Using the timer time **▼** / **▼** buttons, set up a type. **4**
(For example, 4-way air discharge cassette type is 0001) Refer to the attached table.
 - 3) Push **SET** button. (OK when the display goes on.) **5**
 - 4) Using the set temperature **▼** / **▲** buttons, set **11** to the item code (DN).
 - 5) Using the timer time **▼** / **▲** buttons, set the capacity.
(For example, 0012 for class 80) Refer to the attached table.
 - 6) Push **SET** button. (OK when the display goes on.)
 - 7) Push **TEST** button to return the status to usual stop status. **6**
(Approx. 1 minute is required to start handling of the remote controller.)
5. Next write the contents which have been set up at the local site such as the address setup in EEPROM.
Repeat the above procedure 1. and 2.
6. Using the set temperature **▼** / **▲** buttons, set **01** to the item code (DN).
(Setup of lighting time of filter sign)
7. The contents of the displayed setup data in this time should be agreed with the contents in the previous memorandum in □1.
 - 1) If data disagree, change the displayed setup data to that in the previous memorandum by the timer time **▼** / **▲** buttons, and then push **SET** button. (OK when the display goes on.)
 - 2) There is nothing to do when data agrees.
8. Using the set temperature **▼** / **▲** buttons, change the item code (DN).
As same as the above, check the contents of the setup data and then change them to data contents in the previous memorandum.
9. Then repeat the procedure 7. and 8.
10. After completion of setup, push **TEST** button to return the status to the usual stop status. **6**
(Approx. 1 minute is required to start handling of the remote controller.)

* **01** to **9F** are provided in the item code (DN).
On the way of operation, DN No. may come out.
When data has been changed by mistake and **SET** button has been pushed, the data can be returned to the data before change by pushing **CL** button if the item code (DN) was not yet changed.

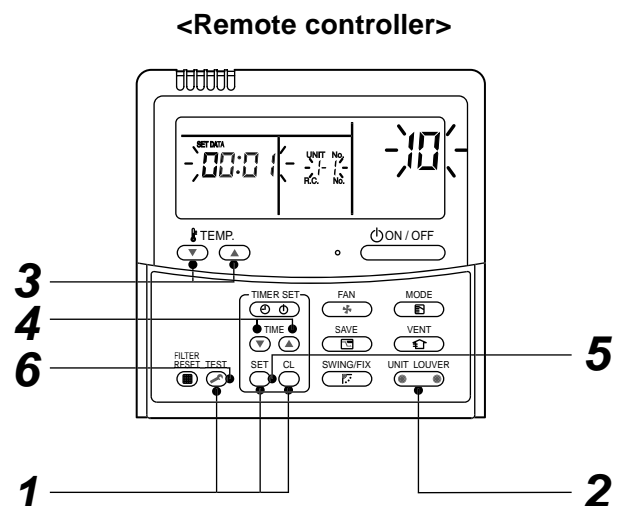

Memorandum for setup contents (Item code table (Example))

DN	Item	Memo	At shipment
01	Filter sign lighting time		According to type
02	Dirty state of filter		0000: Standard
03	Central control address		0099: Unfixed
06	Heating suction temp shift		0002: +2°C (Floor type: 0)
0F	Cooling only		0000: Shared for cooling/heating
10	Type		According to model type
11	Indoor unit capacity		According to capacity type
12	Line address		0099: Unfixed
13	Indoor unit address		0099: Unfixed
14	Group address		0099: Unfixed
19	Flap type (Adjustment of air direction)		According to type
1E	Temp difference of automatic cooling/ heating selecting control points		0003: 3 deg (Ts ± 1.5)
28	Automatic reset of power failure		0000: None
2A	Option		0002:
2b	Thermo output selection		0000: Thermo ON
2E	Option		0000:
32	Sensor selection		0000: Body sensor
5d	High ceiling selection		0000: Standard
60	Timer set (Wired remote controller)		0000: Available
8b	Correction of high heat feeling		0000: None

Type

Item code [10]

Setup data	Type	Abbreviated name
0014	Compact 4-way cassette	RAV-SM***MUT-E

* Initial setup value of EEPROM installed on the service P.C. board

Indoor unit capacity

Item code [11]

Setup data	Type	Abbreviated name
0006	Compact 4-way cassette	RAV-SM402MUT-E
0007		RAV-SM452MUT-E
0009		RAV-SM562MUT-E



* Initial setup value of EEPROM installed on the service P.C. board

11. SETUP AT LOCAL SITE AND OTHERS

11-1. Indoor Unit





11-1-1. Test Run Setup on Remote Controller

<Wired remote controller>

1. When pushing  button on the remote controller for 4 seconds or more, "TEST" is displayed on LC display. Then push  button.
 - "TEST" is displayed on LC display during operation of Test Run.
 - During Test Run, temperature cannot be adjusted but air volume can be selected.
 - In heating and cooling operation, a command to fix the Test Run frequency is output.
 - Detection of error is performed as usual. However, do not use this function except case of Test Run because it applies load on the unit.
2. Use either heating or cooling operation mode for [TEST].

NOTE : The outdoor unit does not operate after power has been turned on or for approx. 3 minutes after operation has stopped.
3. After a Test Run has finished, push  button again and check that [TEST] on LC display has gone off. (To prevent a continuous test run operation, 60-minutes timer release function is provided to this remote controller.)

<Wireless remote controller>

1. Remove a screw which fixes the serial plate of the receiver part on the wireless remote controller. Remove the nameplate of the receiver section by inserting a minus screwdriver, etc. into the notch at the bottom of the plate, and set the Dip switch to [TEST RUN ON].
2. Execute a test operation with  button on the wireless remote controller.
 - ,  and  LED flash during test operation.
 - Under status of [TEST RUN ON], the temperature adjustment from the wireless remote controller is invalid. Do not use this method in the operation other than test operation because the equipment is damaged.
3. Use either [COOL] or [HEAT] operation mode for test operation.
 - The outdoor unit does not operate approx. 3 minutes after power-ON and operation stop.
4. After the test operation finished, stop the air conditioner from the wireless remote controller, and return Dip switch of the sensor section as before. (A 60 minutes timer clearing function is attached to the sensor section in order to prevent a continuous test operation.)

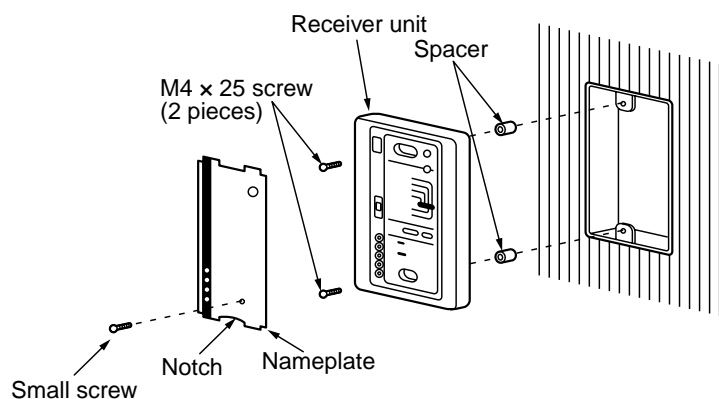

<In case of wireless remote controller>

Procedure	Description	
1	Turn on power of the air conditioner.	
	The operation is not accepted for 5 minutes when power has been turned on at first time after installation, and 1 minute when power has been turned on at the next time and after. After the specified time has passed, perform a test operation.	
2	Push [Start/Stop] button and change the operation mode to [COOL] or [HEAT] with [Mode] button. Then change the fan speed to [High] using [Fan] button.	
3	Test cooling operation	Test heating operation
	Set temperature to [18°C] using [Temperature set] button.	Set temperature to [30°C] using [Temperature set] button.
4	After checking the receiving sound "Pi", immediately push [Temperature set] button to set to [19°C]	After checking the receiving sound "Pi", immediately push [Temperature set] button to set to [29°C].
5	After checking the receiving sound "Pi", immediately push [Temperature set] button to set to [18°C].	After checking the receiving sound "Pi", immediately push [Temperature set] button to set to [30°C].
6	Then repeat the procedure 4 → 5 → 4 → 5 . After approx. 10 seconds, all the display lamps on the sensor part of wireless remote controller, [Operation] (Green), [Timer] (Green), and [Ready] (Yellow) flash and the air conditioner starts operation. If the lamps do not flash, repeat the procedure 2 and after.	
7	After the test operation, push [Start/Stop] button to stop the operation.	

<Outline of test operation from the wireless remote controller>

Test cooling operation:

Start → 18°C → 19°C → 18°C → 19°C → 18°C → 19°C → 18°C → (Test operation) → Stop

Test heating operation:

Start → 30°C → 29°C → 30°C → 29°C → 30°C → 29°C → 30°C → (Test operation) → Stop

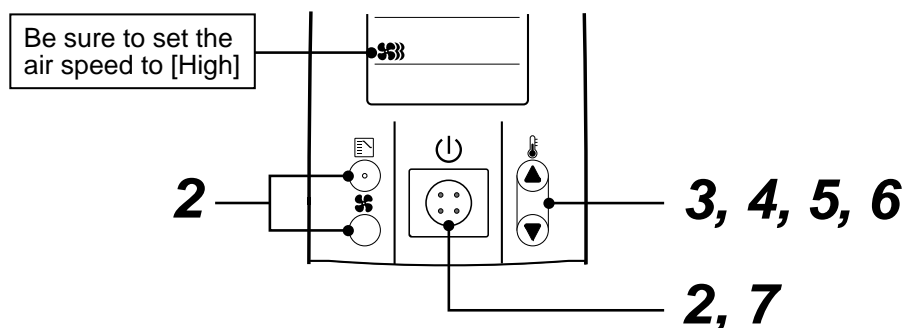

Item No. (DN) table (Selection of function)

DN	Item	Description	At shipment
01	Filter sign lighting time	0000 : None 0002 : 2500H (4-Way/Duct/Ceiling Type)	0002 for D.I. and S.D.I. models
02	Dirty state of filter	0000 : Standard 0001 : High degree of dirt (Half of standard time)	0000 : Standard
03	Central control address	0001 : No.1 unit to 0064 : No.64 unit 0099 : Unfixed	0099 : Unfixed
06	Heating suction temp shift	0000 : No shift 0001 : +1°C 0002 : +2°C to 0010 : -10°C (Up to recommendation + 6)	0002 : +2°C (Floor type 0000: 0°C)
0F	Cooling only	0000 : Heat pump 0001 : Cooling only (No display of [AUTO] [HEAT])	0000 : Shared for cooling/heating
10	Type	0014 : SM562MUT-E	According to model type
11	Indoor unit capacity	0000 : Unfixed 0009 : 562 type 0012 : 802 type 0015 : 1102 type 0017 : 1402 type	According to capacity type
12	Line address	0001 : No.1 unit to 0030 : No.30 unit	0099 : Unfixed
13	Indoor unit address	0001 : No.1 unit to 0064 : No.64 unit	0099 : Unfixed
14	Group address	0000 : Individual 0001 : Master of group 0002 : Sub of group	0099 : Unfixed
19			
1E	Temp difference of automatic cooling/heating mode selection COOL → HEAT, HEAT → COOL	0000 : 0 deg to 0010 : 10 deg (For setup temperature, reversal of COOL/HEAT by ± (Data value)/2)	0003 : 3 deg (Ts±1.5)
28	Automatic restart of power failure	0000 : None 0001 : Restart	0000 : None
2A	Option		0002 : Default
2b	Thermo output selection (T10 ③)	0000 : Indoor thermo ON 0001 : Output of outdoor comp-ON receiving	0000: Thermo. ON
2E	Option		0000 : Default
30	Option		0000 : Default
31	Option		0000 : Default
32	Sensor selection	0000 : Body TA sensor 0001 : Remote controller sensor	0000 : Body sensor
33	Temperature indication	0000 : °C (celsius) 0001 : °F (Fahrenheit)	0000 : °C
40	Option		0003 : Default
5d	High ceiling selection (Air volume selection)	0000 : Standard (Below 3.2m) 0001 : Standard (Below 3.4m) 0003 : Standard (Below 3.5m)	0000 : Standard
60	Timer set (Wired remote controller)	0000 : Available (Operable) 0001 : Unavailable (Operation prohibited)	0000 : Available
8b	Correction of high heat feeling	0000 : None 0001 : Correction	0000 : None

11-1-2. Wiring and Setting of Remote Controller Control

2-remote controller control (Controlled by 2 remote controllers)

This control is to operate 1 or multiple indoor units are operated by 2 remote controllers.
(Max. 2 remote controllers are connectable.)

• When connected 2 remote controllers operate an indoor unit

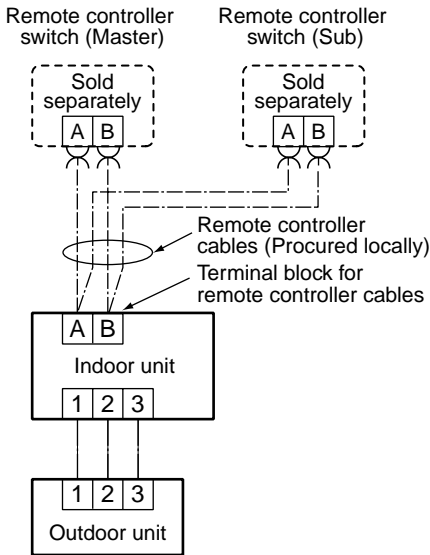

• When connected 2 remote controllers operate the twin

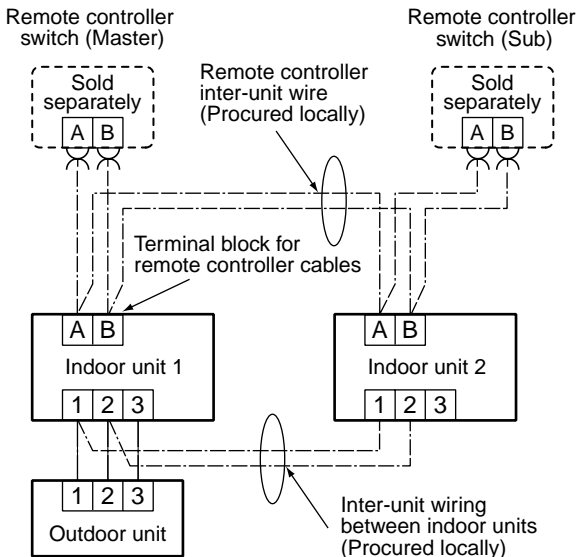

(Setup method)

One or multiple indoor units are controlled by 2 remote controllers.
(Max. 2 remote controllers are connectable.)

<Wired remote controller>

How to set wired remote controller as sub remote controller

Change DIP switch inside of the rear side of the remote controller switch from remote controller master to sub. (In case of RBC-AMT32E)

Remote controller (Inside of the rear side)

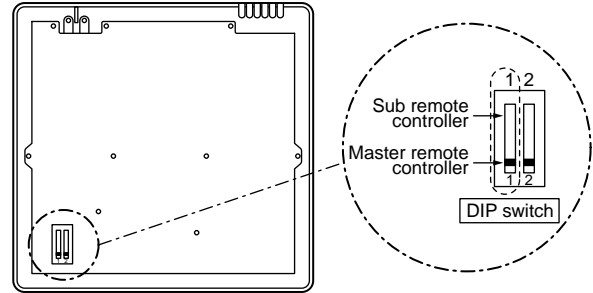

<Wireless remote controller>

How to set wireless remote controller to sub remote controller

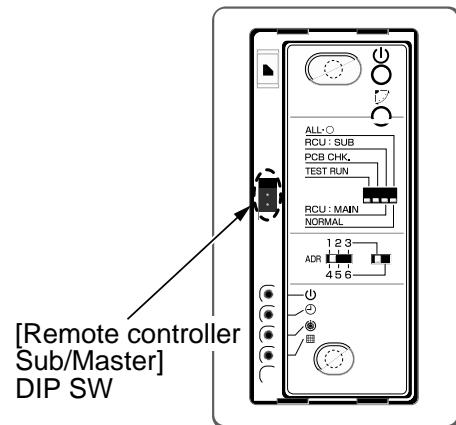

[Operation]

1. The operation contents can be changed by Last-push-priority.
2. Use a timer on either Master remote controller or Sub remote controller.



11-1-3. Monitor Function of Remote Controller Switch

■ Calling of sensor temperature display



<Contents>

Each data of the remote controller, indoor unit and outdoor unit can be understood by calling the service monitor mode from the remote controller.

<Procedure>

- 1 Push  +  buttons simultaneously for 4 seconds to call the service monitor mode.**

The service monitor goes on, the master indoor unit No. is displayed at first and then the temperature of item code **00** is displayed.

- 2 Push temperature set   buttons and then change the item code of data to be monitored.**

The item code list is shown below.

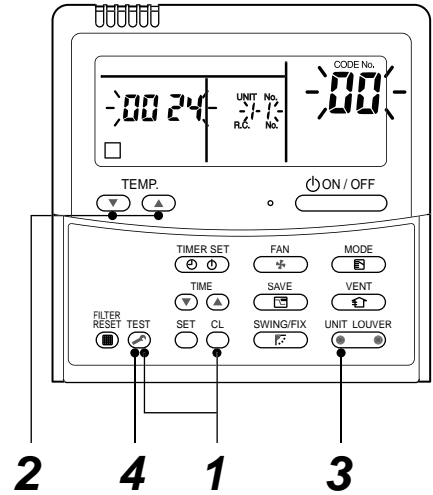

<Operation procedure>

1 → 2 → 3 → 4

Returned to usual display

	Item code	Data name		Item code	Data name
Indoor unit data	00	Room temp. (control temp.) *1	Outdoor unit data	60	Heat exchanger temp. TE
	01	Room temp. (remote controller)		61	Outside temp. TO
	02	Room temp. (TA)		62	Discharge temp. TD
	03	Heat exchanger temp. (TCJ)		63	Suction temp. TS
	04	Heat exchanger temp. (TC)		64	—
			65	Heat sink temp. THS	

*1 Only master unit in group control

- 3 Push  button to select the indoor unit to be monitored. Each data of the indoor unit and its outdoor units can be monitored.**

- 4 Pushing  button returns the status to the usual display.**

*1 The indoor discharge temperature of item code [F8] is the estimated value from TC or TCJ sensor.

Use this value to check discharge temperature at test run.
(A discharge temperature sensor is not provided to this model.)

- The data value of each item is not the real time, but value delayed by a few seconds to ten-odd seconds.
- If the combined outdoor unit is one before 2 or 3 series, the outdoor unit data [6D], [70], [72] and [73] are not displayed.

■ Calling of error history

<Contents>

The error contents in the past can be called.

<Procedure>

- 1 Push **SET** + **TEST** buttons simultaneously for 4 seconds or more to call the service check mode.

Service Check goes on, the item code 01 is displayed, and then the content of the latest alarm is displayed. The number and error contents of the indoor unit in which an error occurred are displayed.

- 2 In order to monitor another error history, push the set temperature **▼** / **▲** buttons to change the error history No. (Item code).

Item code **01** (Latest) → Item code **04** (Old)

NOTE : 4 error histories are stored in memory.

- 3 Pushing **TEST** button returns the display to usual display.

REQUIREMENT

Do not push **CL** button, otherwise all the error histories of the indoor unit are deleted.

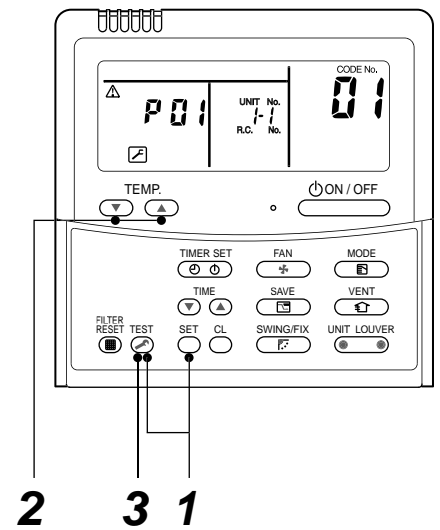

<Operation procedure>

1 → 2 → 3

Returned to usual display

(Group control operation)

In a group control, operation of maximum 8 indoor units can be controlled by a remote controller.

The indoor unit connected with outdoor unit (Individual/Master of twin) controls room temperature according to setting on the remote controller.

<System example>

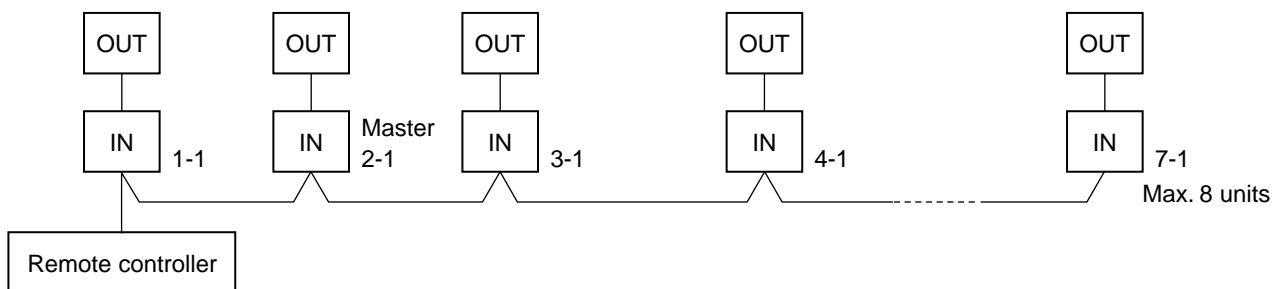

1. Display range on remote controller

The setup range (Operation mode/Air volume select/Setup temp) of the indoor unit which was set to the master unit is reflected on the remote controller.

2. Address setup

Turn on power of the indoor unit to be controlled in a group within 3 minutes after setting of automatic address.

If power of the indoor unit is not turned on within 3 minutes (completion of automatic address setting), the system is rebooted and the automatic address setting will be judged again.

- 1) Connect 3 In/Out cables surely.
- 2) Check line address/indoor address/group address of the unit one by one.
- 3) The unit No. (line/indoor gout address) which have been set once keep the present status as a rule if the unit No. is not duplicated with one of another unit.

■ Indoor unit power-ON sequence

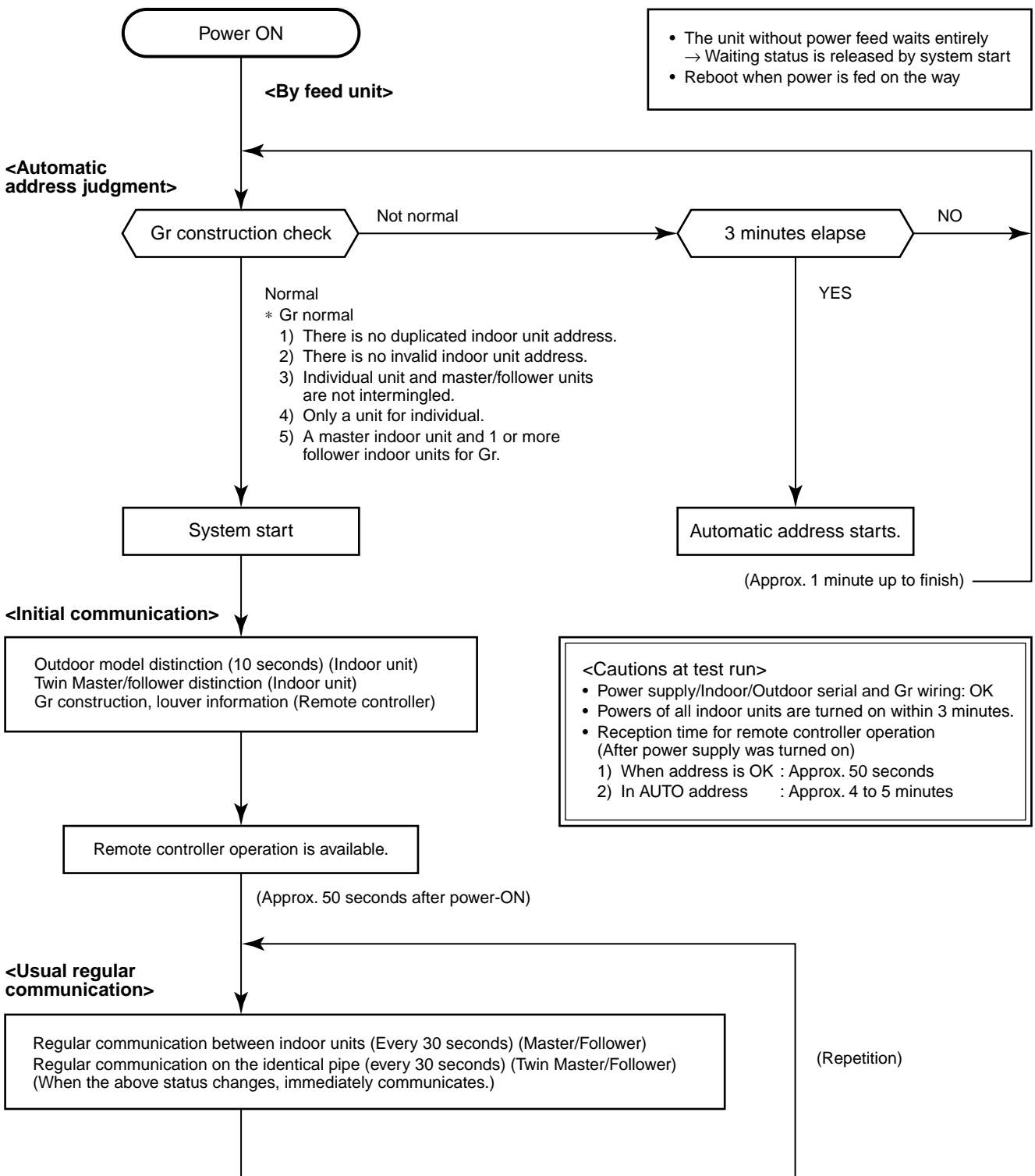

- In a group operation, if the indoor unit which was fed power after judgment of automatic address cannot receive regular communication from the master unit and regular communication on identical pipe within 120 seconds after power was turned on, it reboots (system reset).
→ The operation starts from judgment of automatic address (Gr construction check) again.
(If the address of the master unit was determined in the previous time, the power fed to the master unit and reboot works, the master unit may change though the indoor unit line address is not changed.)

11-2. Setup at Local Site / Others

Model name: TCB-PCNT30TLE2 and TCB-PX30MUE

11-2-1. TCC-LINK Adapter (For TCC-LINK Central Control)

1. Function

This model is an optional P.C. board to connect the indoor unit to TCC-LINK (Central controller).

2. Microprocessor Block Diagram

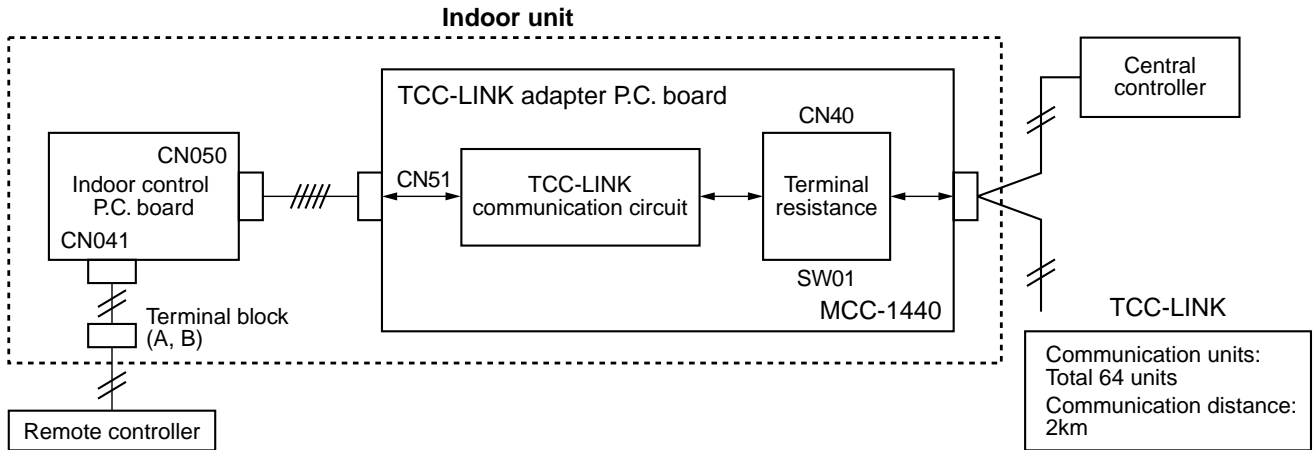

3. Installation Procedure

- 1) Cut off the slit of bell mouth on the Air Conditioner unit (RAV-SM***MUT-E) with nipper or a cutter for attaching the Connection Interface Kit.

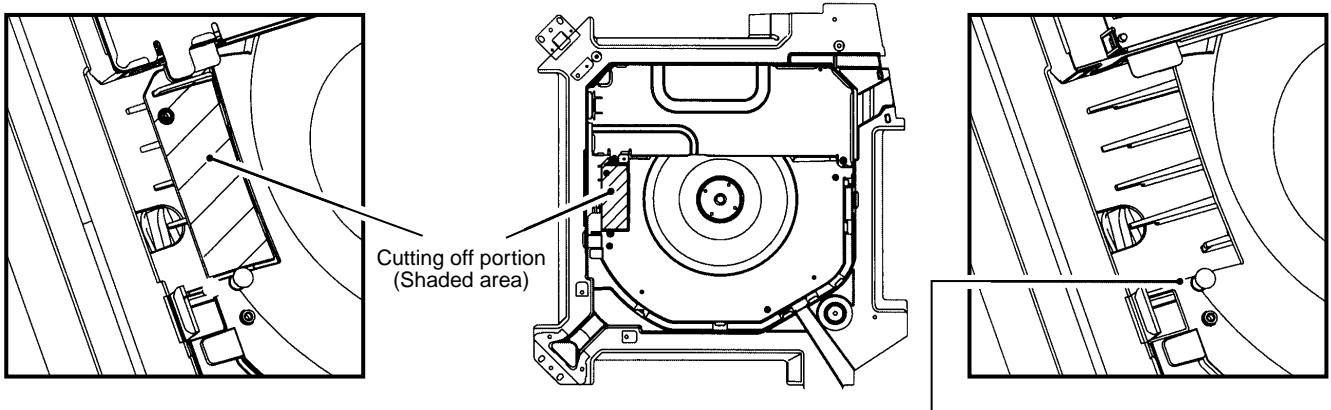

After cutting off the slit of bell mouth on the unit, clear up the surface of the slit that there is no burr on the cutting edge.

- 2) Attach the Connection Interface Kit (TCB-PX30MUE) on the Air Conditioner unit (RAV-SM***MUT-E).

After insert the hook of the unit to the Connection Interface Kit hole, and then tighten a Cross slot screw (4 × 14).

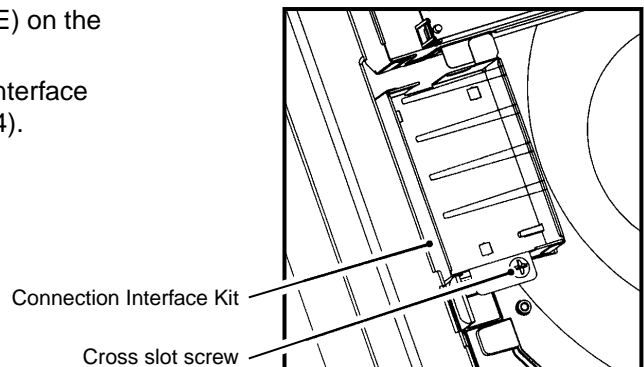

3) Install the spacers and P.C. board that are attached to TCB-PCNT30TLE2, on the Connection Interface Kit.

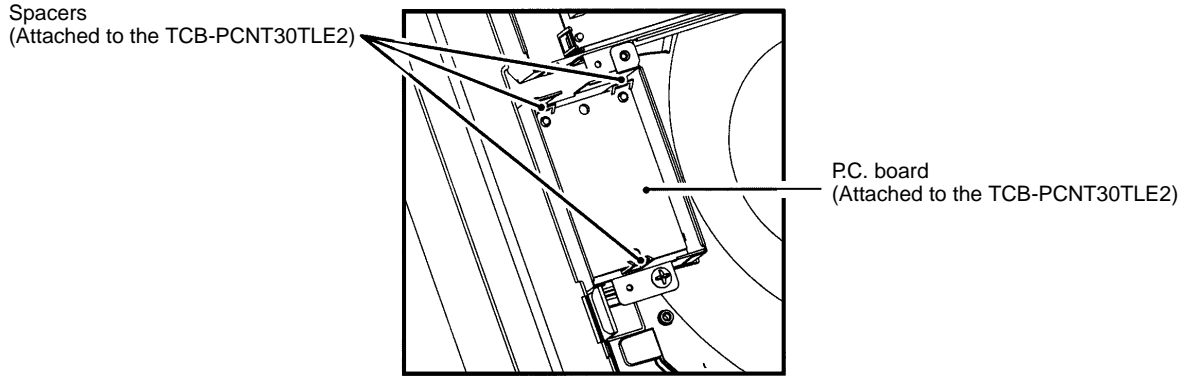

- 4) Remove the 2P terminal block for the communication cable of the electric parts box on the unit, and then replace with the attached 4P terminal block for the communication wires.
- Disconnect the lead wires on the 2P terminal block of the electric parts box from the Faston connector on the unit.
 - Replace the 2P connector with 4P connector on the terminal block.
 - Connect the lead wires that are disconnected as shown above steps a), to the 4P terminal block.

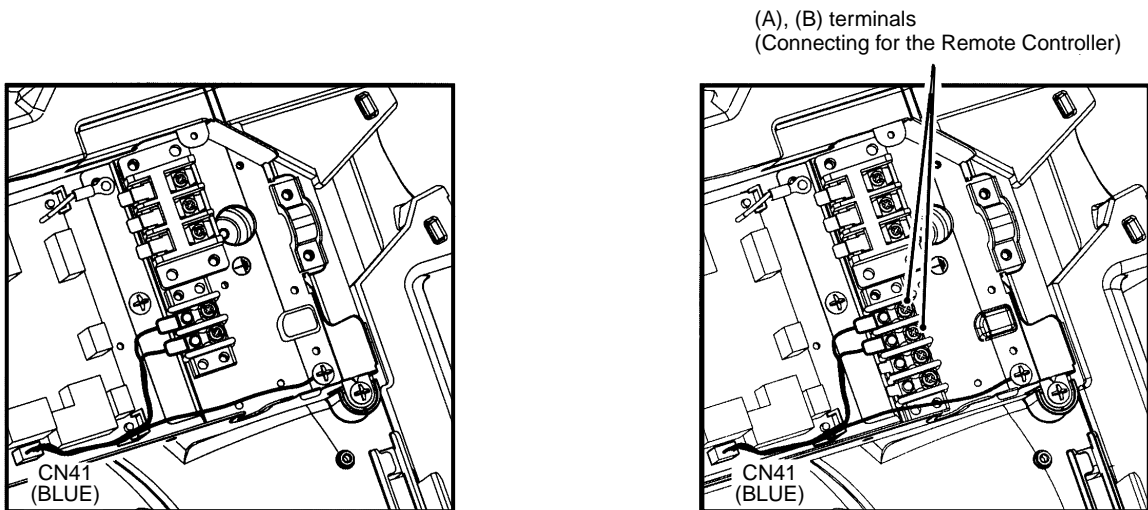

5) Connect the connection cables attached to the electric parts block.

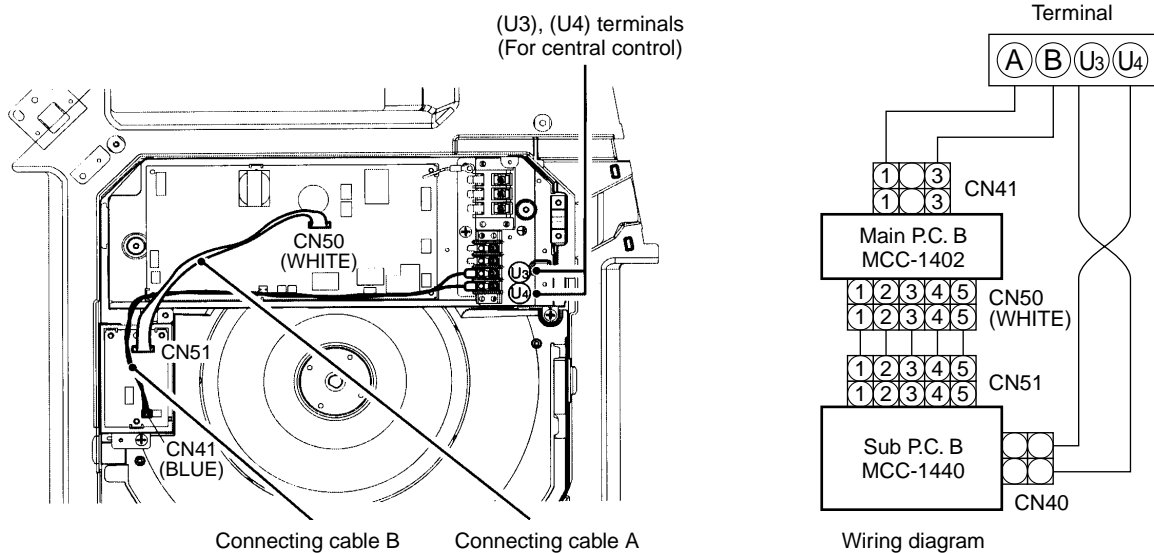

6) Setting for Central Control

For Central Control setting, refer to the Installation Manual of the TCB-PCNT30TLE2.

7) After the installation work has been completed, install the Connection Interface Kit cover to the Connection Interface Kit tightened with the two screws (4 x10).

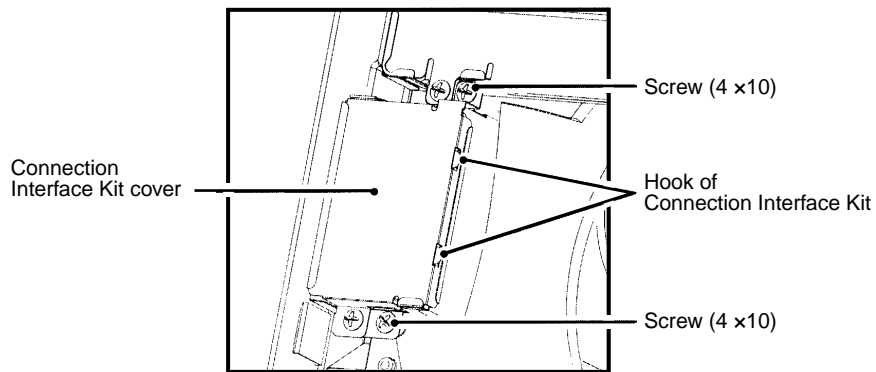

4. TCC-LINK Wiring Connection

CAUTION

- 1) When controlling customized setup collectively, TCC-LINK adapter (This option) is required.
- 2) In case of group operation or twin/triple operation, the adapter is necessary to be connected to the main unit.
- 3) Connect the central control devices to the central control system wiring.
- 4) When controlling collectively customized setup only, turn on only Bit 1 of SW01 of the least line of the system address No. (OFF when shipped from the factory)

*** In case of customized setup, the address is necessary to be set up again from the wired remote controller after automatic addressing.**

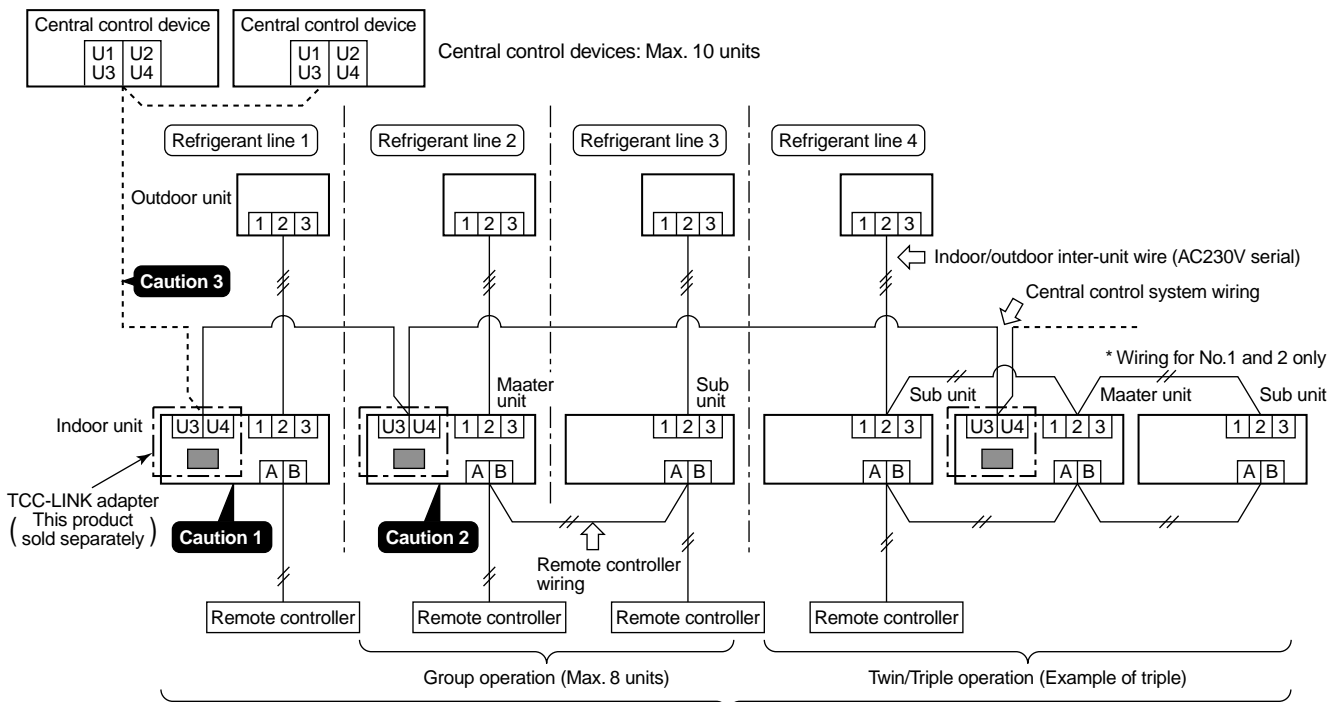

Indoor units in all refrigerant lines: Max. 64 units
 [If mixed with multi model (Link wiring), multi indoor units are included.]
 * However group sub units and twin/triple sub units of customized setup are not included in number of the units.

5. Wiring Specifications

- Use 2-core with no polar wire.
- Match the length of wire to wire length of the central control system.

If mixed in the system, the wire length is lengthened with all indoor/outdoor inter-unit wire length at side.

- To prevent noise trouble, use 2-core shield wire.
- Connect the shield wire by closed-end connection and apply open process (insulating process) to the last terminal. Ground the earth wire to 1 point at indoor unit side. (In case of central controlling of digital inverter unit setup)

No. of wires	Size
2	Up to 1000m: twisted wire 1.25mm ² Up to 2000m: twisted wire 2.0mm ²

CAUTION

- 1) Closed-end connection of shield wire (Connect all the connecting parts of each indoor unit)
- 2) Apply open process to the last terminal (insulating process).
- 3) Ground earth wire to 1 point at indoor unit side.

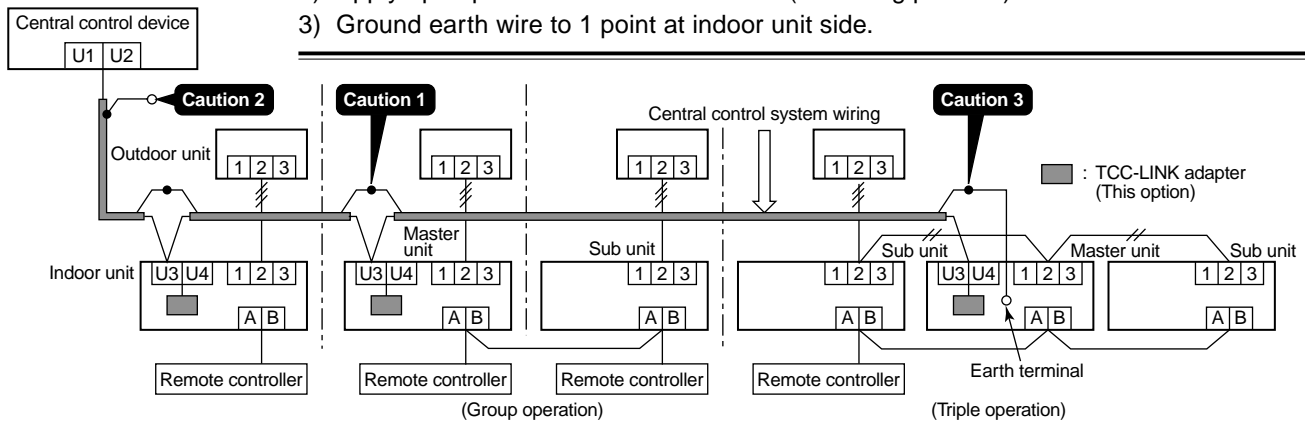

6. P.C. Board Switch (SW01) Setup

When performing collective control by customized setup only, the setup of terminator is necessary.

- Using SW01, set up the terminator.
- Set up the terminator to only the adapter connected to the indoor unit of least line address No.

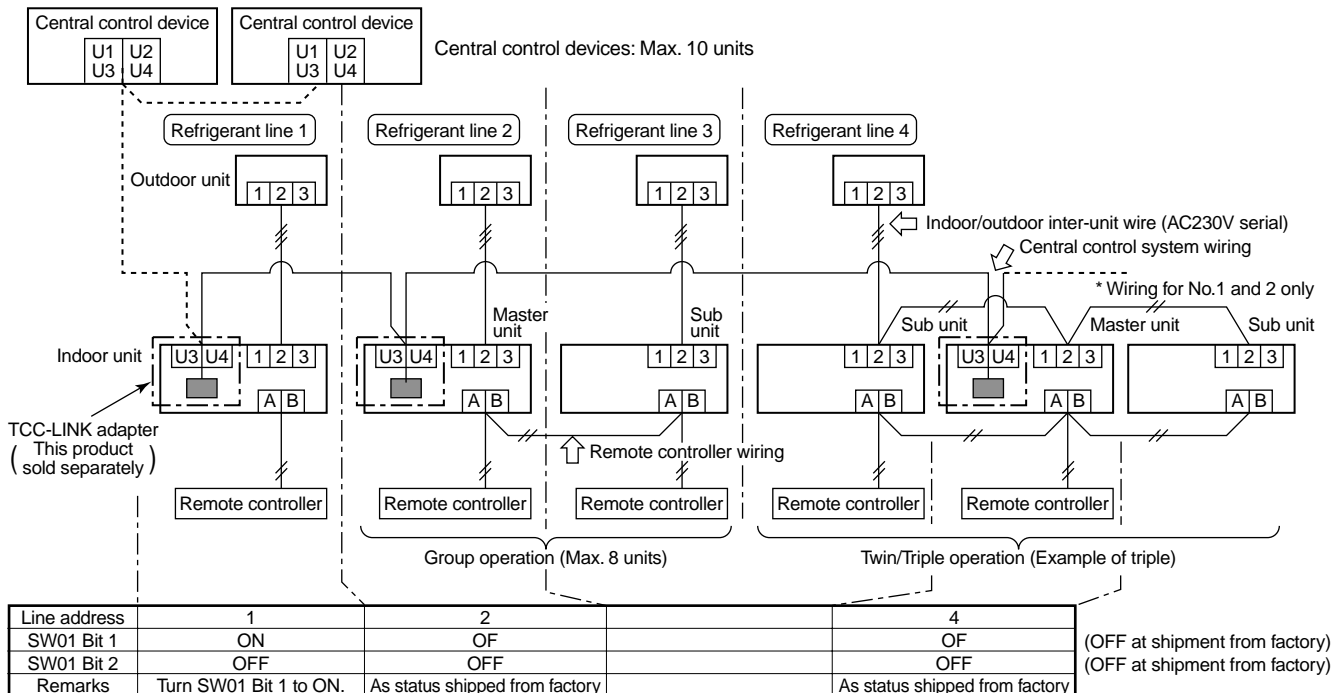

(Reference) Setup contents of switch

SW01		Terminator	Remarks
Bit 1	Bit 2		
OFF	OFF	None	Mixed with multi (Link wiring) at shipment from factory
ON	OFF	100Ω	Central control by digital inverter only
OFF	ON	75Ω	Spare
ON	ON	43Ω	Spare

7. External view of P.C. board assembly

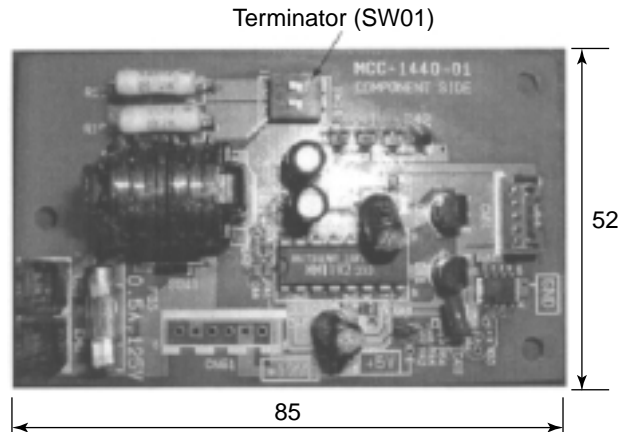

8. Address setup

In addition to set up the central control address, it is necessary to change the indoor unit number. (Line/Indoor/Group address). For details, refer to TCC-LINK Adapter Installation Manual.

11-3. How to Set up Central Control Address Number

When connecting the indoor unit to the central control remote controller using TCC-LINK adapter, it is necessary to set up the central control address number.

- The central control address number is displayed as the line No. of the central control remote controller.

1. Setup from remote controller at indoor unit side

- * If you use the network adapter P.C. board, it is effective only when No. 7 of setup switch SW01 on P.C. board is turned off.

<Procedure> Perform setup while the unit stops.

1 Push **TEST** + **VENT** buttons for 4 seconds or more.

When group control is executed, first the unit No. **ALL** is displayed and all the indoor units in the group control are selected. In this time, fans of all the selected indoor units are turned on. (Fig. 1)
(Keep **ALL** displayed status without pushing **UNIT LOUVER** button.)

In case of individual remote controller which is not group-controlled, Line address and Indoor unit address are displayed.

2 Using temperature setup **TEMP.** buttons, specify item code **03**.

3 Using timer time **TIME** buttons, select the setup data. The setup data is shown in the table below (Table 1).

4 Push **SET** button. (OK if display goes on.)

- To change the item to be set up, return to Procedure 2.

5 Push **TEST** button.

The status returns to usual stop status.

(Table 1)

Setup data	Central control address No.
0001	1
0002	2
0003	3
⋮	⋮
0064	64
0099	Unset (Setup at shipment from factory)

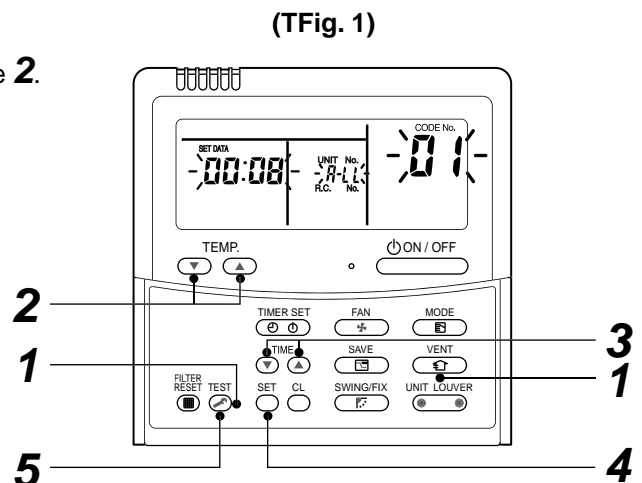

12. ADDRESS SETUP

12-1. Address Setup Procedure

When an outdoor unit and an indoor unit are connected, or when an outdoor unit is connected to each indoor unit respectively in the group operation even if multiple refrigerant lines are provided, the automatic address setup completes with power-ON of the outdoor unit. The operation of the remote controller is not accepted while automatic address works. (Approx. 4 to 5 minutes)

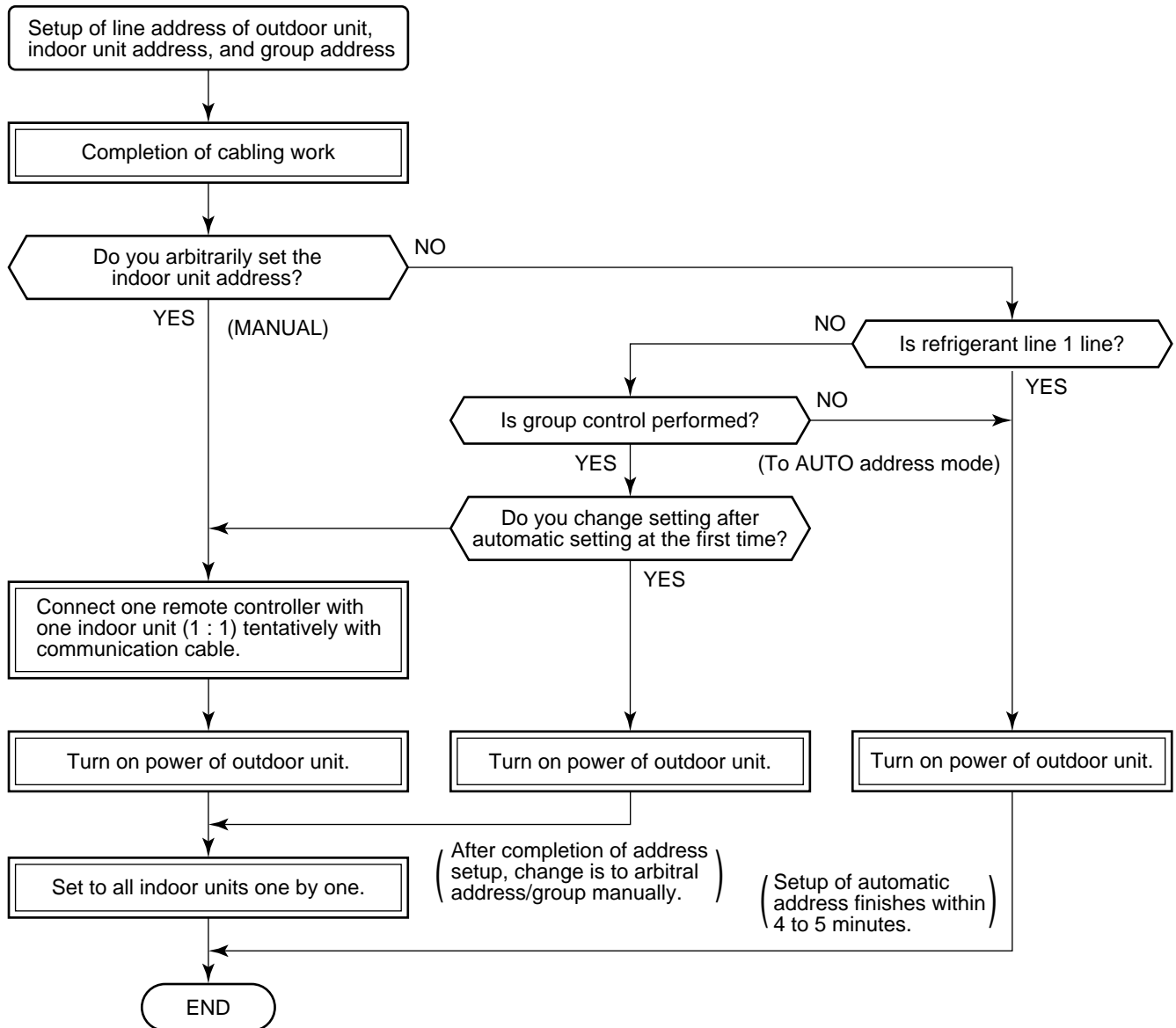

- When the following addresses are not stored in the neutral memory (IC503) on the indoor P.C. board, a test run operation cannot be performed. (Unfixed data at shipment from factory)

	Item code	Data at shipment	Setup data range
Line address	12	0099	0001 (No. 1 unit) to 0064 (No. 64 unit)
Indoor unit address	13	0099	0001 (No. 1 unit) to 0064 (No. 64 unit) Max. value of indoor units in the identical refrigerant line
Group address	14	0099	0000 : Individual (Indoor units which are not controlled in a group) 0001 : Master unit (1 indoor unit in group control) 0002 : Sub unit (Indoor units other than master unit in group control)

12-2. Address Setup & Group Control

<Terminology>

Indoor unit No. : N - n = Outdoor unit line address N (Max. 30) - Indoor unit address n (Max. 64)

Group address : 0 = Single (Not group control)
 1 = Master unit in group control
 2 = Sub unit in group control

Master unit (= 1) : The representative of multiple indoor units in group operation sends/receives signals to/from the remote controllers and sub indoor units.
 (* It has no relation with an indoor unit which communicates serially with the outdoor units.)
 The operation mode and setup temperature range are displayed on the remote controller LCD.
 (Except air direction adjustment of louver)

Sub unit (= 2) : Indoor units other than master unit in group operation
 Basically, sub units do not send/receive signals to/from the remote controllers.
 (Except errors and response to demand of service data)

Header unit (Representative unit) (Master Twin)

: This unit communicates with the indoor unit (follower) which serial-communicates with the outdoor units and sends/receives signal (Command from compressor) to/from the outdoor units as the representative of the cycle control in the indoor units of the identical line address within the minimum unit which configures one of the refrigerating cycles of Twin.

Follower unit (Subordinate unit) (Sub Twin)

: Indoor units excluding the header unit in Twin

This unit communicates with (Header) indoor unit in the identical line address and performs control synchronized with (Header) indoor unit.

This unit does not perform the signal send/receive operation with the outdoor units. :
 No judgment for serial signal error.

12-2-1. System Configuration

1. Single

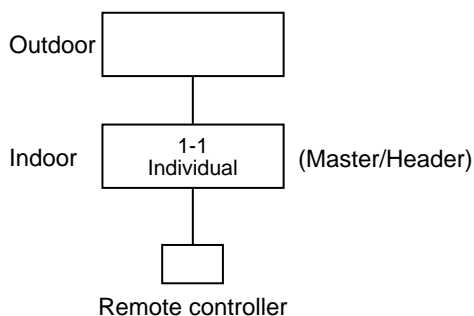

2. Twin

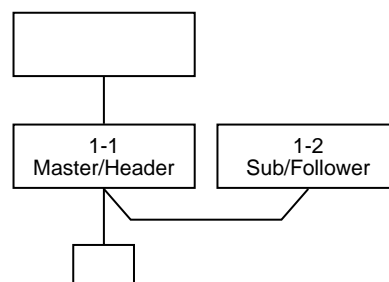

3. Triple

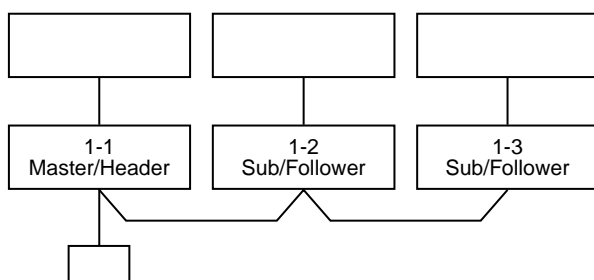

4. Single group operation

- Each indoor unit controls the outdoor unit individually.

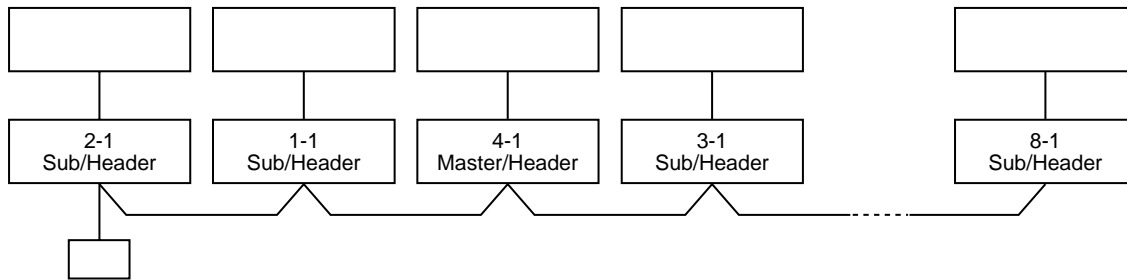

5. Multiple groups operation (Manual address setting)

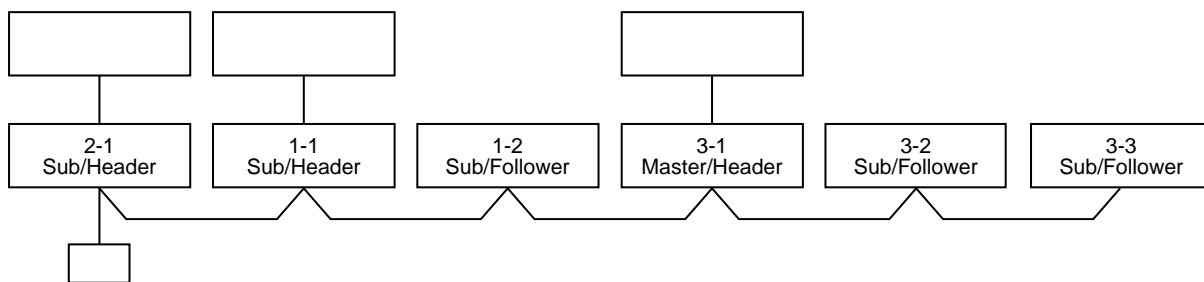

- Header unit: The header unit receives the indoor unit data (thermo status) of the follower (Without identical line address & indoor/outdoor serial) and then finally controls the outdoor compressor matching with its own thermo status.
The header unit sends this command information to the follower unit.
- Follower unit: The follower unit receives the indoor unit data from the header (With identical line address & indoor/outdoor serial) and then performs the thermo operation synchronized with the header unit.
The follower unit sends own thermo ON/OFF demand to the header unit.

(Example)

No. 1-1 header unit sends/receives signal to/from No. 1-2 and No. 1-3 follower units.
(It is not influenced by the line 2 or 3 address indoor unit.)

12-2-2. Automatic Address Example from Unset Address (No miswiring)

1. Standard (One outdoor unit)

1) Single

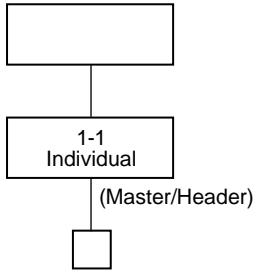

2) Twin

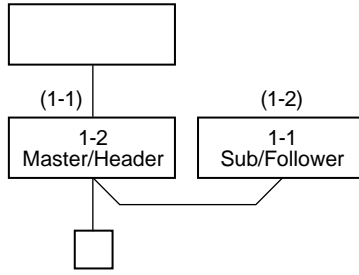

3) Triple

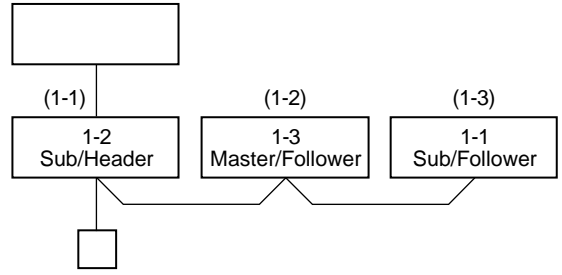

Only turning on source power supply (Automatic completion)

2. Group operation

(Multiple outdoor units = Multiple indoor units with serial communication only, without twin)

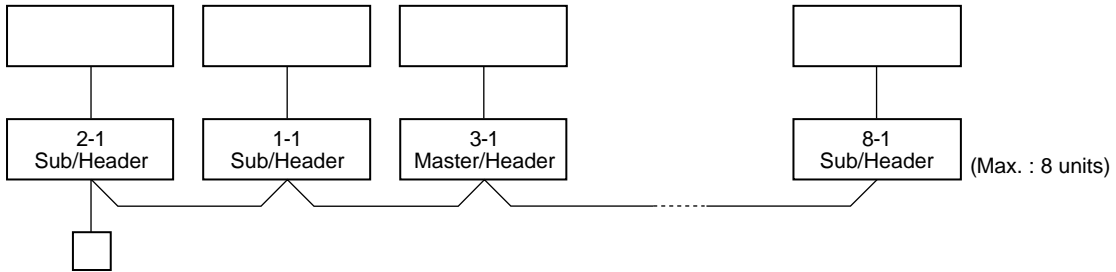

Only turning on source power supply (Automatic completion)

3. Multiple groups operation

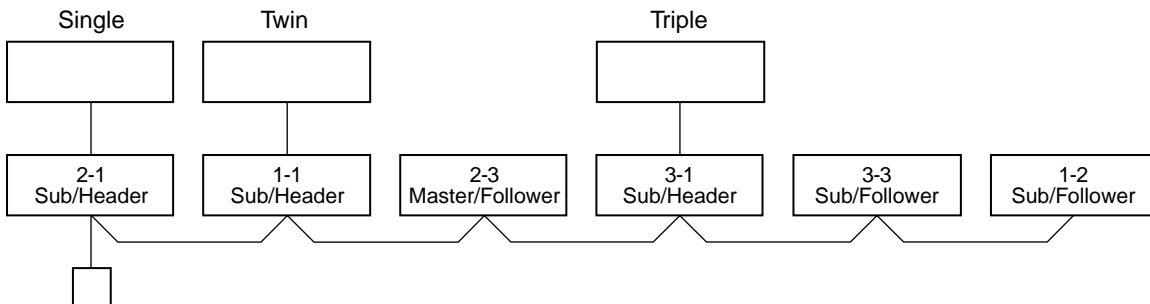

Change is necessary
Manually change addresses of the multiple follower units
simultaneously from the remote controller.

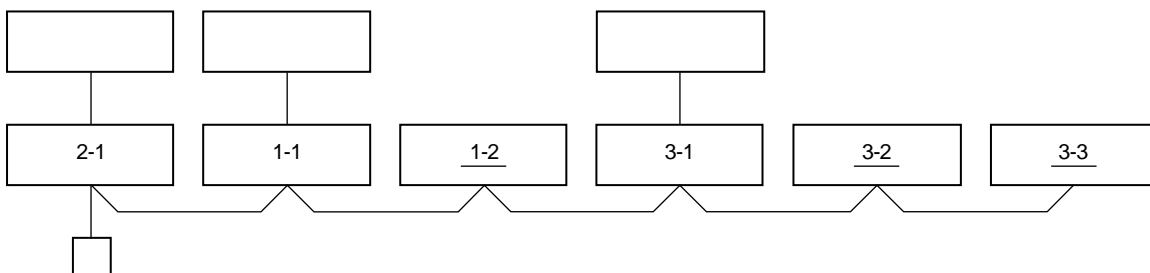

12-3. Address Setup (Manual Setting from Remote Controller)

In case that addresses of the indoor units will be determined prior to piping work after cabling work

- Set an indoor unit per a remote controller.
- Turn on power supply.

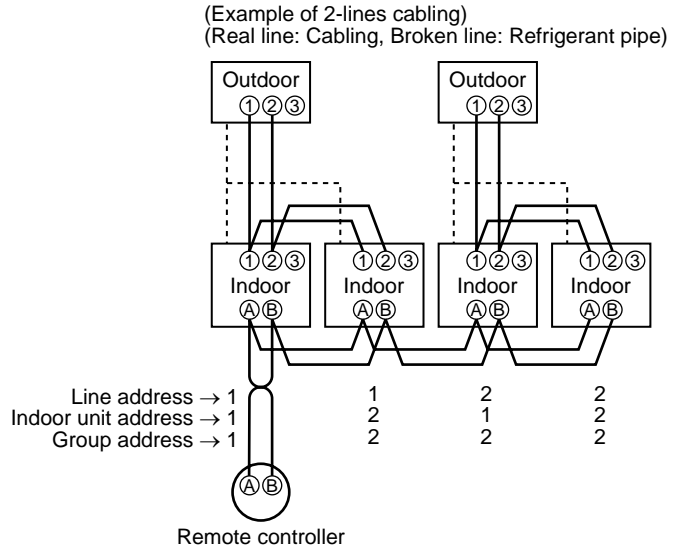

For the above example, perform setting by connecting singly the wired remote controller without remote controller inter-unit cable.

Group address
 Individual : 0000
 Master unit : 0001
 Sub unit : 0002 } In case of group control

- 1 Push **SET** + **CL** + **TEST** buttons simultaneously for 4 seconds or more.
- 2 (← Line address)
Using the temperature setup **▼** / **▲** buttons, set **1** to the item code.
- 3 Using timer time **▼** / **▲** buttons, set the line address.
- 4 Push **SET** button. (OK when display goes on.)
- 5 (← Indoor unit address)
Using the temperature setup **▼** / **▲** buttons, set **1** to the item code.
- 6 Using timer time **▼** / **▲** buttons, set 1 to the line address.
- 7 Push **SET** button. (OK when display goes on.)
- 8 (← Group address)
Using the temperature setup **▼** / **▲** buttons, set **1** to the item code.
- 9 Using timer time **▼** / **▲** buttons, set **0000** to Individual, **0001** to Master unit, and **0002** to sub unit.
- 10 Push **SET** button. (OK when display goes on.)
- 11 Push **TEST** button.
Setup completes. (The status returns to the usual stop status.)

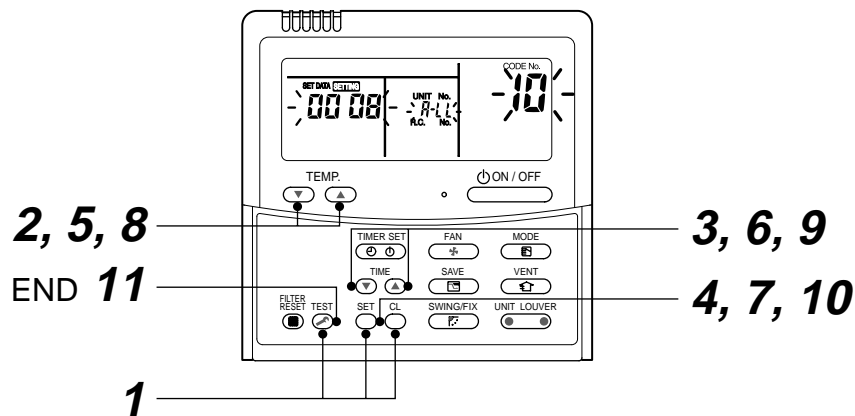

<Operation procedure>

1 → 2 → 3 → 4 → 5 → 6 → 7 → 8 → 9 → 10 → 11 END

12-4. Confirmation of Indoor Unit No. Position

1. To know the indoor unit addresses though position of the indoor unit body is recognized

- In case of individual operation (Wired remote controller : indoor unit = 1 : 1)
(Follow to the procedure during operation)

<Procedure>

1 Push  button if the unit stops.

2 Push  button.

Unit No. *1-1* is displayed on LCD.

(It disappears after several seconds.)

The displayed unit No. indicate line address and indoor unit address.

(When other indoor units are connected to the identical remote controller (Group control unit), other unit numbers are also displayed every pushing  button.

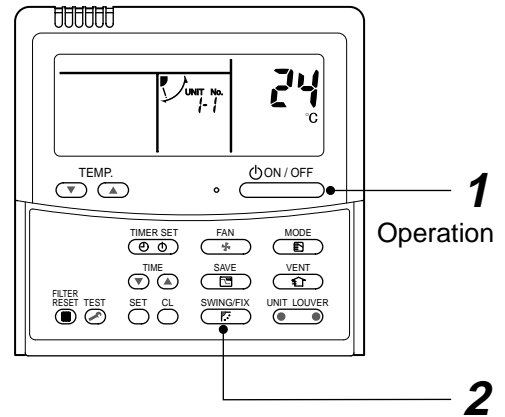

<Operation procedure>



1 → 2 END

2. To know the position of indoor unit body by address

- To confirm the unit No. in the group control
(Follow to the procedure during operation) (in this procedure, the indoor units in group control stop.)

<Procedure>

The indoor unit numbers in the group control are successively displayed, and fan, louver, and drain pump of the corresponding indoor unit are turned on.
(Follow to the procedure during operation)

1 Push  and  buttons simultaneously for 4 seconds or more.

- Unit No. *ALL* is displayed.
- Fans and louvers of all the indoor units in the group control operate.

2 Every pushing  button, the unit numbers in the group control are successively displayed.

- The unit No. displayed at the first time indicates the master unit address.
- Fan and louver of the selected indoor unit only operate.

3 Push  button to finish the procedure.
All the indoor units in the group control stop.

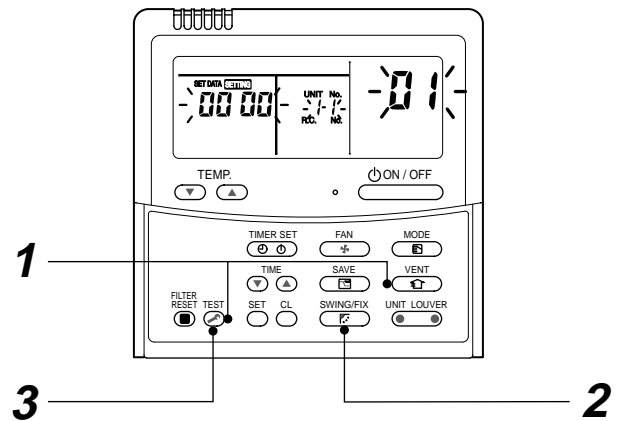

<Operation procedure>

1 → 2 → 3 END

13. DETACHMENTS

13-1. Indoor Unit

Ceiling panel: RBC-UM11PG(W)E

Preparing work:

1. Before work, be sure to stop the power supply of the air conditioner and turn off switch of the power supply breaker. (Otherwise an electric shock may be caused.)
2. Be sure to put on the gloves when working; otherwise an injury may be caused with parts sharp edges etc.

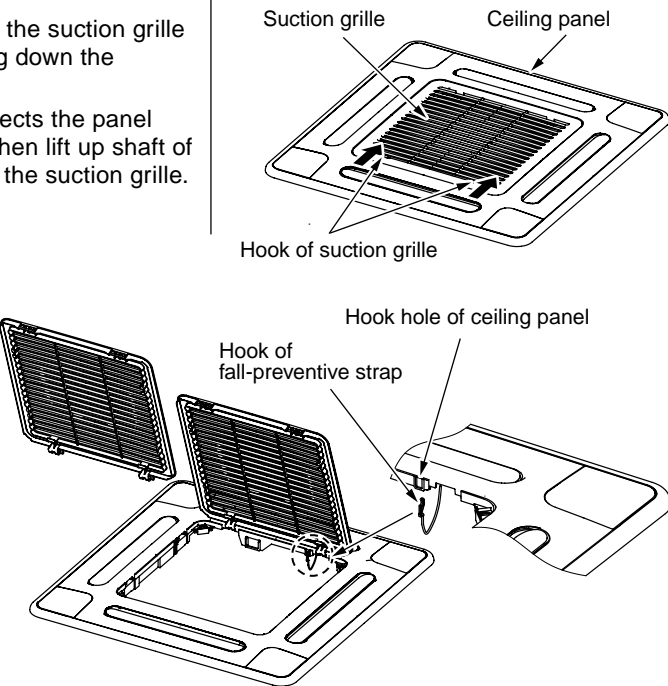
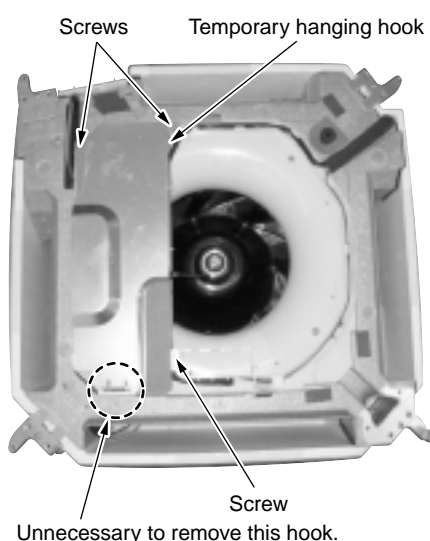
No.	Part name	Procedure	Remarks
①	Suction grille	<p>1. Detachment</p> <ol style="list-style-type: none"> 1) Slide hooks (2 positions) of the suction grille to inner side, and then hang down the suction grille. 2) Take off the strap that connects the panel and the suction grille, and then lift up shaft of the suction grille to remove the suction grille. <p>2. Attachment</p> <ol style="list-style-type: none"> 1) Hook shaft of the suction grille to the panel. 2) Hook strap of the suction grille to the original position of the panel. 3) Close the suction grille and slide the hooks outward to fix it. 	 <p>Suction grille Ceiling panel</p> <p>Hook of suction grille</p> <p>Hook hole of ceiling panel</p> <p>Hook of fall-preventive strap</p>
②	Electric parts cover	<p>1. Detachment</p> <ol style="list-style-type: none"> 1) Perform work of procedure ① -1. 2) Take off screws (Ø4 × 10, 3 pcs.) fixing the electric parts cover. 3) Remove the electric parts cover from the temporary hanging hook of the electric parts cover, and then open the cover. <p>2. Attachment</p> <ol style="list-style-type: none"> 1) Close the electric parts cover and hook the cover hole to the temporary hanging hook. 2) Tighten the fixing screws. (Ø4 × 10, 3 pcs.) 	 <p>Screws Temporary hanging hook</p> <p>Screw</p> <p>Unnecessary to remove this hook.</p>

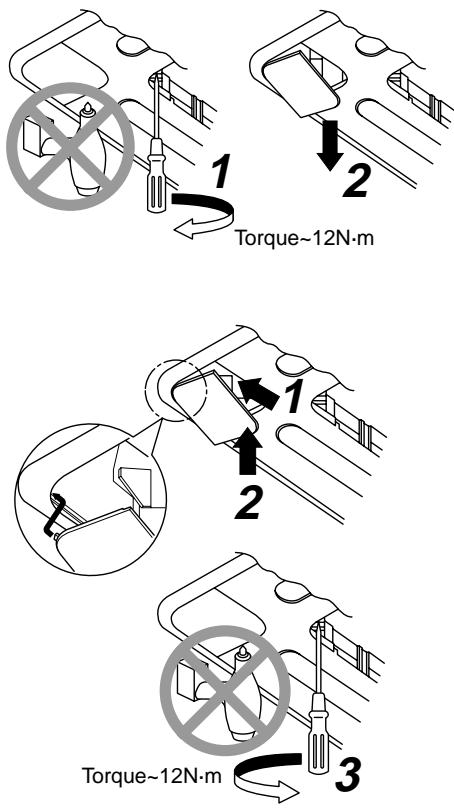
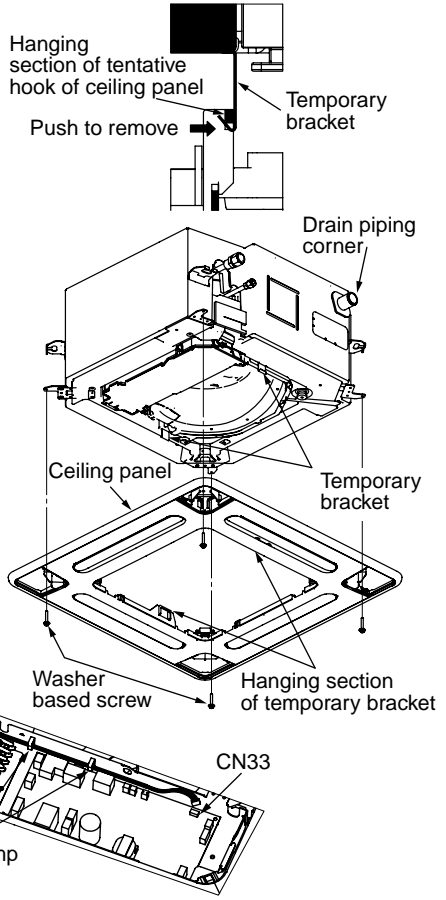
No.	Part name	Procedure	Remarks
③	Adjust corner cover	<p>1. Detachment</p> <ol style="list-style-type: none"> 1) Perform work of procedure of ① -1. 2) Turn clockwise screws (4 positions) at the suction port corner until adjust corner cover rises up. <p>NOTE) When you work, keep the torque at below 12N•m. Do not use an electric screwdriver; otherwise the mechanism of adjust corner cover may be damaged and not be removed.</p> <ol style="list-style-type: none"> 3) Pull downward the risen-up part of adjust corner cover and remove it. 4) Remove the strap of adjust corner cover. <p>2. Attachment</p> <ol style="list-style-type: none"> 1) Attach the strap of adjust corner cover to the panel, hook claws of adjust corner cover to the panel corner, and then push the opposite side into the panel. 2) Turn screws (4 positions) of the suction port corner counterclockwise until bump between adjust corner cover and panel disappears. <p>NOTE) When you work, keep the torque at below 12N•m. Do not use an electric screwdriver; otherwise the mechanism of adjust corner cover may be damaged and not be removed.</p>	
④	Ceiling panel	<p>1. Detachment</p> <ol style="list-style-type: none"> 1) Perform works of procedure ① -1-, ② -1-, and ③ -1. 2) Remove the flap connector (CN33, White, 5P) connected to the control P.C. board and then take off the lead wire from the clamp. <p>NOTE) Remove the connectors after unlocking the lock of the housing.</p> <ol style="list-style-type: none"> 3) Take off screws (M5, 4 pcs.) fixing the ceiling panel. 4) Push the temporary bracket to inner side to remove the ceiling panel. <p>2. Attachment</p> <ol style="list-style-type: none"> 1) Hook the panel to the temporary bracket of the drain pan of the main body. <p>NOTE) The panel has directionality. Therefore mount the panel according to the temporary bracket and the bracket mounting position.</p> <ol style="list-style-type: none"> 2) Tighten the fixing screws. (M5, 4 pcs.) 3) Connect flap connector of the ceiling panel to the connector (CN33, White, 5P) of the control P.C. board. 	

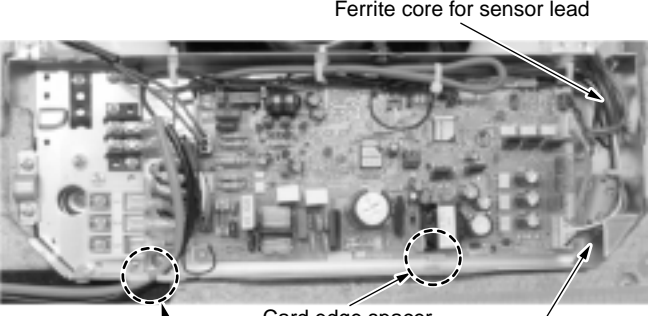
No.	Part name	Procedure	Remarks
⑤	Control P.C. board	<p>1. Detachment</p> <ol style="list-style-type: none"> 1) Perform works of procedure ① -1- and ② -1-. 2) Remove the connectors connected from the control P.C. board to other parts. CN33 : Flap motor (5P, White) CN34 : Float switch (3P, Red) CN41 : Terminal block of remote controller (3P, Blue) CN40 : Terminal block of crossover between inside and outside (5P, Black) CN68 : Drain pump (3P, Blue) CN67 : Terminal block of power supply (3P, Black) CN101 : TC sensor (2P, Black) CN102 : TCJ sensor (2P, Red) CN104 : Room temp sensor (2P, Yellow) CN333 : Fan motor power supply (5P, White) CN334 : Fan motor position detection (5P, White) <p>NOTE) Remove the connectors after unlocking the lock of the housing.</p> <ol style="list-style-type: none"> 3) Unlock the lock of the card edge spacer (6 positions) and then remove the control P.C. board. <p>2. Attachment</p> <ol style="list-style-type: none"> 1) Fix the control P.C. board to the card edge spacer. (6 positions) 2) Connect the connectors as original before being removed in item 1. <p>NOTE) For drawing of each wire and position of ferrite core, perform wiring same as those before removing. If there is incomplete drawing of wire, short or water leakage of the parts may be caused.</p> <p>Fix the sensor lead wires with cord clamps (2 positions) so that it does not slacken at P.C. board side and draw wires as shown in the figure.</p> <p>Tighten together the shield wires of the sensor lead wires and the remote controller. Be careful that other sensor does not fall out.</p> <p>Adhere on the transformer. Turn up the sensor lead wires and fix surely with the cord clamp.</p> <p>Arrow view E</p> <p>Please note the float SW lead wires are set at inner side of the fan motor lead wires.</p> <p><Details of sensor lead wire drawing></p> <p>As shown in the figure, hook the sensor lead wires to claw of the piping cover and then pass them so that they are stored in the groove.</p> <p>After mounting the piping cover, check each lead wire does not hit the liquid pipe.</p> <p><Details of piping cover assembly and mounting></p> <p><Details of fan motor lead wire drawing></p>	

No.	Part name	Procedure	Remarks
⑥	Electric parts box	<p>1. Detachment</p> <ol style="list-style-type: none"> 1) Perform works of procedure ① -1-and ② -1. 2) Remove connectors of the lead wire connected to the following connectors of the control P.C. board. CN33 : Flap motor (5P, White) CN34 : Float switch (3P, Red) CN68 : Drain pump (3P, Blue) CN101 : TC2 sensor (2P, Black) CN102 : TCJ sensor (2P, Red) CN333 : Fan motor power supply (5P, White) CN334 : Fan motor position detection (5P, White) <p>NOTE) Remove the connectors after unlocking the lock of the housing.</p> <ol style="list-style-type: none"> 3) Remove each lead wire from cord clamps in the electric parts box. 4) Remove the power supply wiring, remote controller wiring, and crossover wiring. 5) Take off screws (Ø4 × 10, 2 pcs.) <p>2. Attachment</p> <ol style="list-style-type: none"> 1) Tighten screws (Ø4 × 10, 2 pcs.) fixing the electric parts box. 2) Connect the connectors as original before being removed in item 1. 3) Perform power supply wiring, remote controller wiring, and crossover wiring between inside and outside. <p>NOTE) For drawing of each wire and position of ferrite core, perform wiring same as those before removing. If there is incomplete drawing of wire, short or water leakage of the parts may be caused.</p> <p>Fix the sensor lead wires with cord clamps (2 positions) so that it does not slacken at P.C. board side and draw wires as shown in the figure.</p> <p>Adhere on the transformer. Turn up the sensor lead wires and fix surely with the cord clamp.</p> <p>Tighten together the shield wires of the sensor lead wires and the remote controller. Be careful that other sensor does not fall out.</p> <p>Turn up the fan motor lead wires and fix surely with the cord clamp. (There should be no catching of lead wire by P.C. board.)</p> <p>Clamp (yellow, gray, black) lead wires of the fan motor and arrange them as shown in the figure.</p>	<p>Remarks</p> <p>Ferrite core for sensor lead</p> <p>Card edge spacer</p> <p>Drawing-out port of lead wire</p> <p>Ferrite core for fan motor</p> <p>Arrow view E</p> <p>Please note the float SW lead wires are set at inner side of the fan motor lead wires.</p>

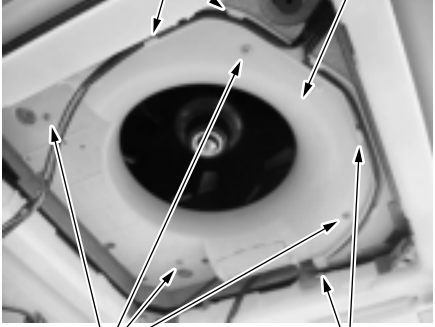
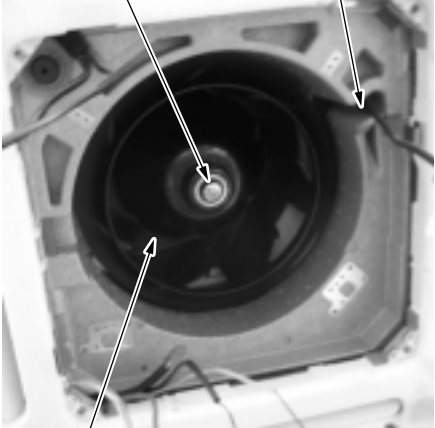
No.	Part name	Procedure	Remarks
⑦	Bell mouth	<p>1. Detachment</p> <ol style="list-style-type: none"> 1) Perform work of procedure ① -1. 2) Take off the lead wires of the drain pump, float switch, and fan motor from the bell mouth. 3) Take off fixing screws of the bell mouth. (Ø4 × 10, 4 pcs.) <p>2. Attachment</p> <ol style="list-style-type: none"> 1) Mount the bell mouth with screws. (Ø4 × 10, 4 pcs.) 2) Perform wiring as original before being removed. <p>NOTE) Pinch lead wire of the drain pump and float switch with lead wire fixing claws of the bell mouth and perform wiring along the guide.</p>	 <p>Fixing claws for lead wires</p> <p>Bell mouth</p> <p>4 screws</p> <p>Fixing claws for lead wires</p>
⑧	Turbo fan	<p>1. Detachment</p> <ol style="list-style-type: none"> 1) Perform work of procedure ⑦ -1. 2) Take off the nut (M6 nut 1 pc.) of the turbo fan. <p>NOTE) Use a box wrench for attachment and detachment of the turbo fan. If using a monkey wrench etc, the other parts may be damaged in work.</p> <p>2. Attachment</p> <ol style="list-style-type: none"> 1) Insert the turbo fan into the fan motor so that boss of the turbo fan matches with cut surface of the fan motor, and then tighten it with nut. <p>NOTE) Tightening torque of turbo fan: $5.9 \pm 0.6\text{N.m}$ Apply looseness-preventing agent to the nut after tightening.</p>	 <p>Fan motor fixing M6 nut</p> <p>Drawing-out port of fan motor lead wire</p> <p>Turbo fan</p>

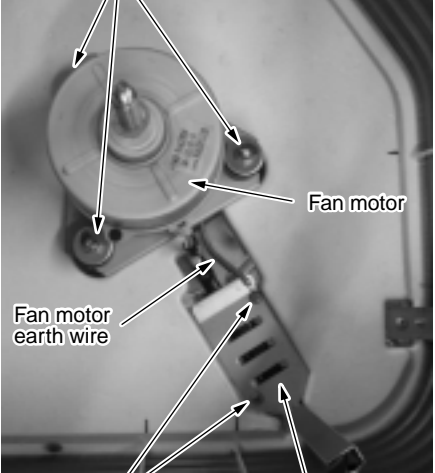
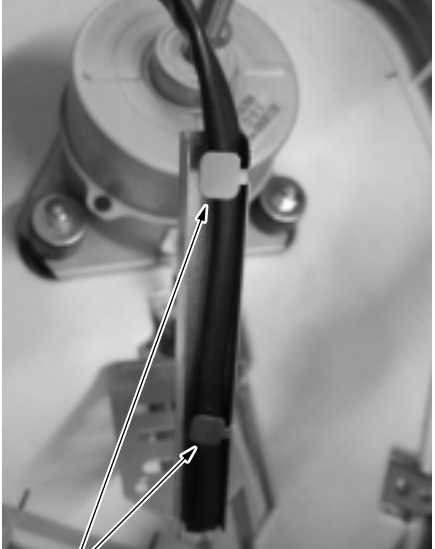
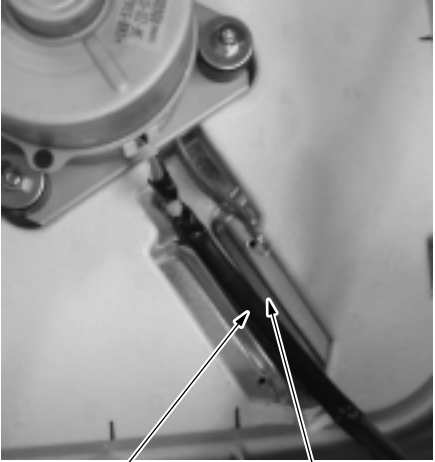
No.	Part name	Procedure	Remarks
⑨	Fan motor	<p>1. Detachment</p> <ol style="list-style-type: none"> 1) Perform work of procedure ⑧. 2) Take off screws fixed with lead holding bracket of the fan motor. (Ø4 × 10, 2 pcs.) 3) Open wiring holding part of the fan motor lead holding bracket and then take off the fan motor lead wire from the bracket. 4) Take off fixing nuts for the fan motor to remove the fan motor. (M 3 pcs.) <p>NOTE) Use a box wrench for attachment and detachment of the fan motor fixing nuts; otherwise contact or damage for other parts may be caused.</p> <p>2. Attachment</p> <ol style="list-style-type: none"> 1) Mount the fan motor with the fixing nuts. <p>NOTE) Tightening torque of turbo fan: $5.9 \pm 0.6\text{N.m}$ Apply looseness-preventing agent (as paints) to the nut after tightening. <ol style="list-style-type: none"> 2) Attach the fan motor lead wire holder. <p>NOTE)</p> <ul style="list-style-type: none"> • For the fan motor lead wire, fix the lead wire holding bracket along concave part of the ceiling panel. (There is no catch-in of lead wire and ceiling panel.) • When fixing the lead wire bracket, tighten fan motor earth together with the lead wire. • For this work, do not use an electric screwdriver. • Take note the damage of earth terminal. <ol style="list-style-type: none"> 3) Bend the lead wire holding part and fix the fan motor lead wire. <p>NOTE) Be sure that the lead wire does not come to contact with the heat exchanger.</p> </p>	<p>Fixing nut for fan motor</p>  <p>Fan motor</p> <p>Fan motor earth wire</p> <p>Fixing screw</p> <p>Holding metal fitting for fan motor lead wire</p>  <p>Wiring holding bracket</p>  <p>Fan motor lead wire</p> <p>Concave part of ceiling panel</p>

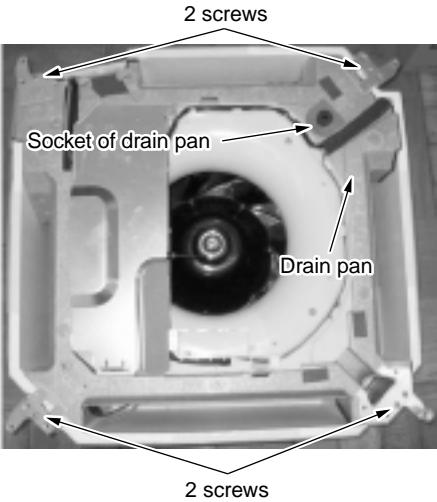
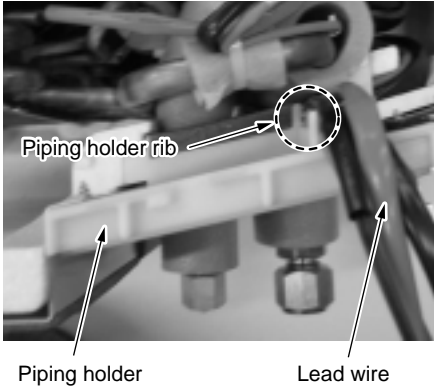
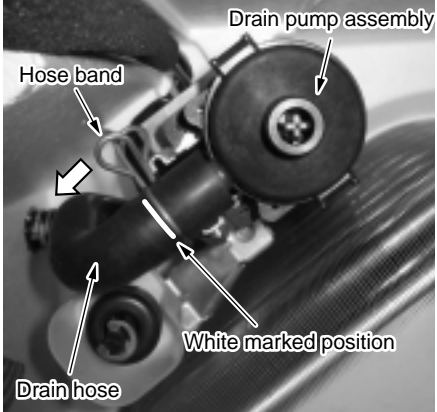
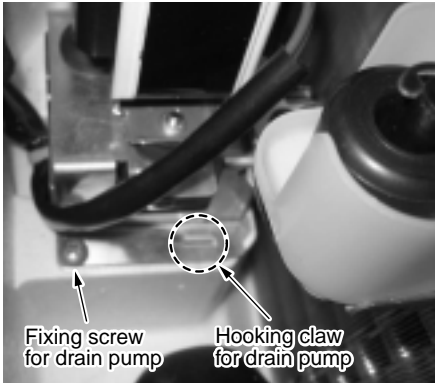
No.	Part name	Procedure	Remarks
⑩	Drain pan	<p>1. Detachment</p> <ol style="list-style-type: none"> 1) Perform works of procedure ④ -1 and ⑦ -1. 2) Remove the drain cap and extract drain water accumulated in the drain pan. <p>NOTE) When removing the drain cap, be sure to receive drain water with a bucket, etc.</p> <ol style="list-style-type: none"> 3) Take off screws fixing the drain pan to remove the drain pan. (Ø4×10, 4 pcs.) <p>2. Attachment</p> <ol style="list-style-type: none"> 1) Insert the drain cap into the drain pan. <p>NOTE) Put a stick or others into hole at center of the drain cap, and then insert the drain cap until it strikes on the socket of the drain pan.</p> <ol style="list-style-type: none"> 2) Draw each lead wire to the correct positions, and then insert the drain pan into the main unit. <p>NOTE) Draw lead wires of the drain pump and the float switch along the guide of the cabinet. Insert the drain pan along the guides of sensors (TC1, TC2, TCJ) and PMV lead wire. The drain pan and each lead wire are not caught in; otherwise water leakage may be caused.</p> <ol style="list-style-type: none"> 3) Fix the drain pan with screws. (Ø4 × 10, 4 pcs.) 	 
⑪	Drain pump assembly	<p>1. Detachment</p> <ol style="list-style-type: none"> 1) Perform work of procedure ⑩ -1. 2) Pick up the hose band and slide it from the pump connecting part to remove the drain hose. 3) Take off screws (Ø4 × 10, 3 pcs.) fixing the drain pump assembly, and then move hooking claw (1 position) of the main body from the drain pump assembly to remove the drain pump assembly. <p>2. Attachment</p> <ol style="list-style-type: none"> 1) Fix the drain pump assembly as original. <p>NOTE) For fixing, use a hooking claw (1 position) and screws (3 positions). When screwing, be sure not to run on the hooking claw at main body side.</p> <ol style="list-style-type: none"> 2) Mount the drain hose and the hose band as original. <p>NOTE) Insert the drain hose up to the end of pump connecting part, and then put the band at white marked position of the hose.</p>	 

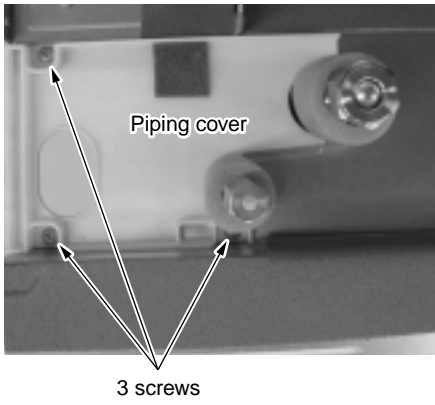
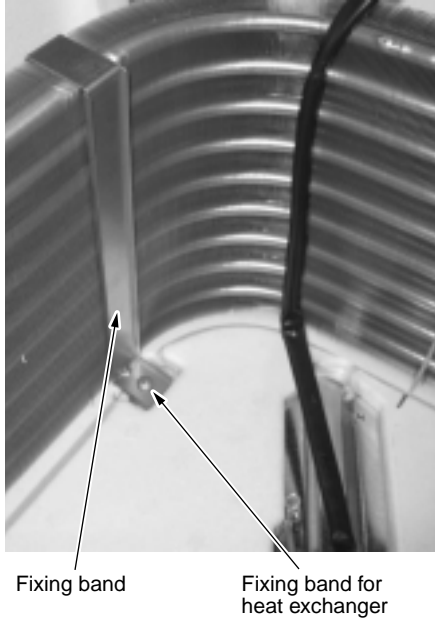
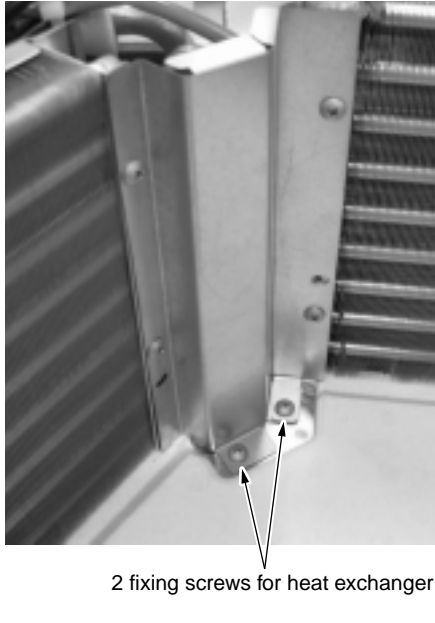
No.	Part name	Procedure	Remarks
⑫	Heat exchanger	<p>1. Detachment</p> <ol style="list-style-type: none"> 1) Recover refrigerant gas. 2) Remove the refrigerant pipe at indoor unit side. 3) Perform work of procedure ⑩ -1. 4) Take off screws (Ø4 × 10, 3 pcs.) fixing the piping cover to remove the piping cover. 5) While holding the heat exchanger, remove fixing band and fixing screws (Ø4 × 10, 3 pcs.) and then remove the heat exchanger. <p>2. Attachment</p> <ol style="list-style-type: none"> 1) Mount parts in order, heat exchanger → fixing band → piping cover → drain pan → bell mouth → electric parts box as original. <p>NOTE) Arrange wires as original.</p> <ol style="list-style-type: none"> 2) Attach the removed connectors and wires as original. 3) Connect the refrigerant pipe as original, and then perform vacuuming. 	  

<Details of sensor lead wire drawing>

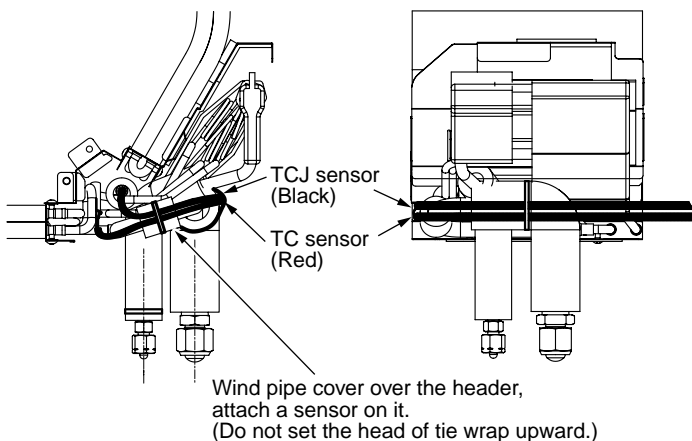

14. EXPLODED VIEWS AND PARTS LIST

14-1. Ceiling Panel

RBC-UM11PG(W)E

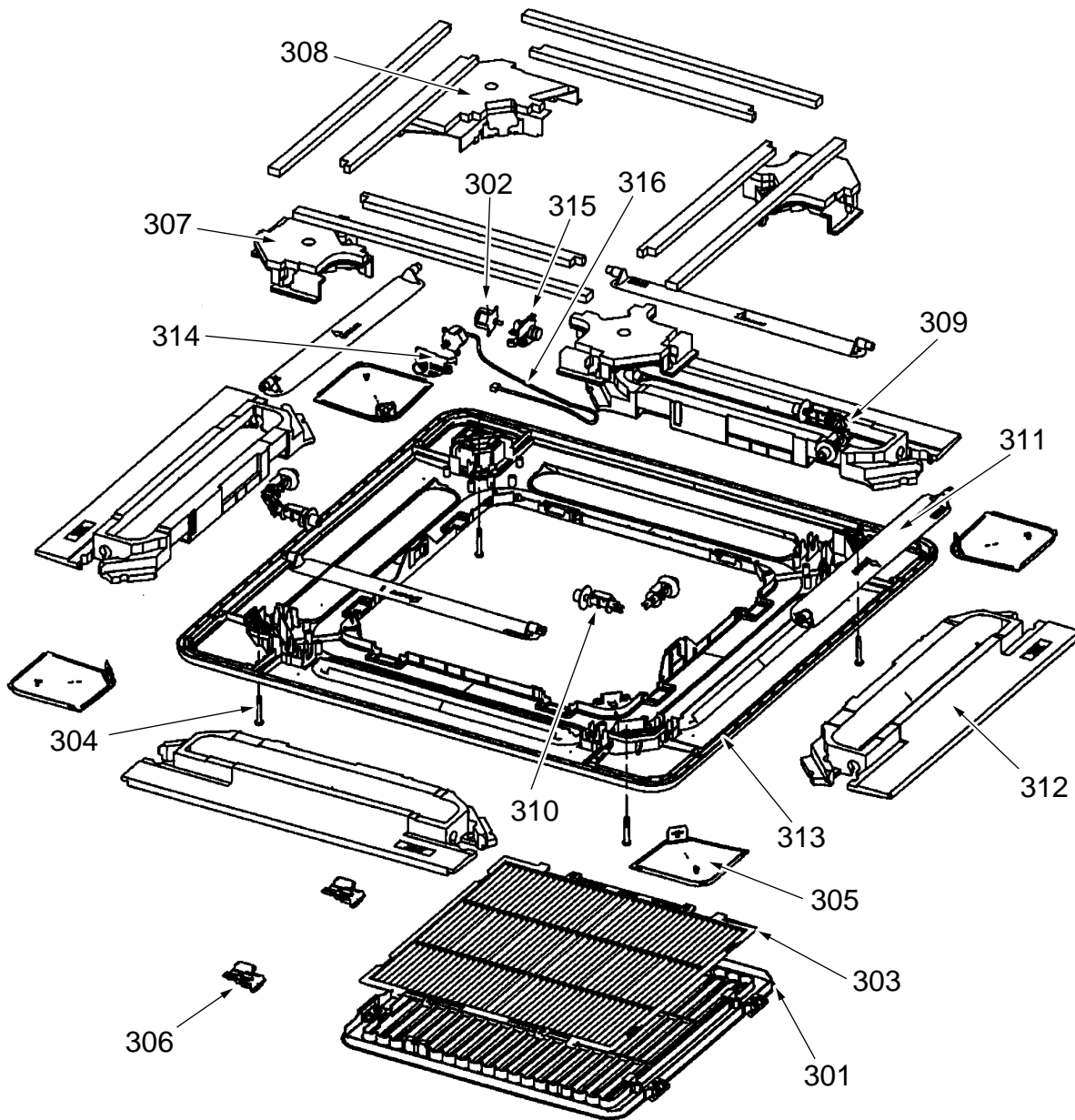

Location No.	Part No.	Description
301	43109414	Grille, Air Inlet
302	4302C059	Motor, Louver
303	43180332	Air Filter
304	43497012	Screw
305	43100322	Cover, Panel Ass'y
306	43107259	Grille, Catch
307	43122089	Cover, Joint (For Joint)
308	43122090	Cover, Joint (For Motor)

Location No.	Part No.	Description
309	43122091	Joint, Kit (A)
310	43122092	Joint, Kit (B)
311	43122093	Louver
312	43107261	Outlet, Air Form
313	43100369	Panel
314	43107262	Fix, Motor
315	43107263	Fix, Motor
316	43160580	Lead, Motor

14-2. Compact 4-way Air Discharge Cassette Type

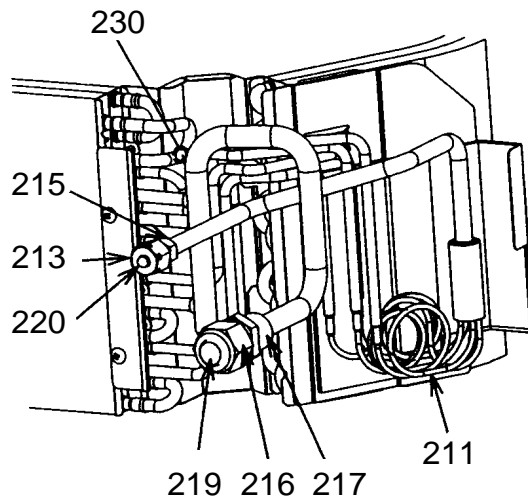
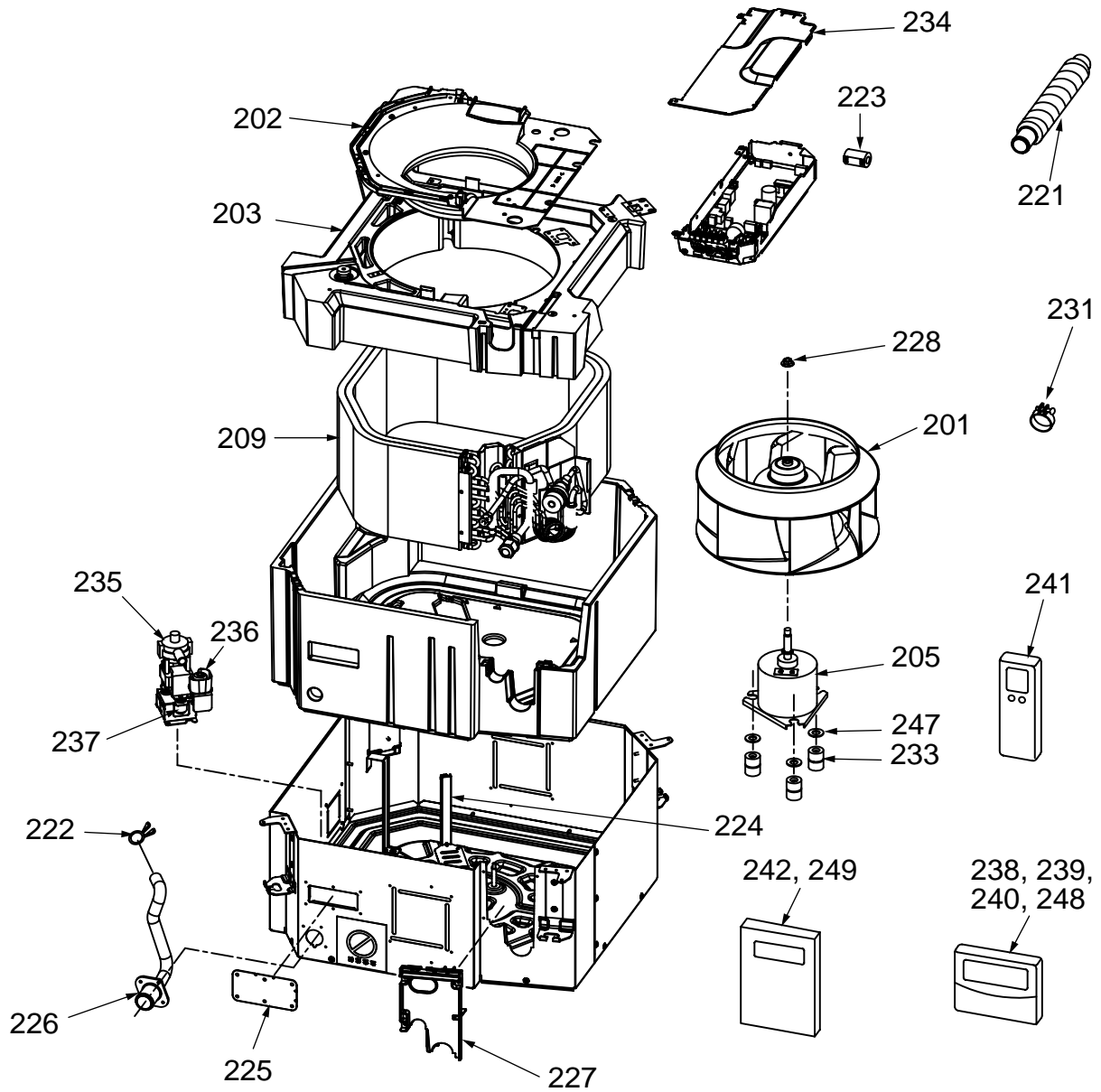

Location No.	Part No.	Description	Model name RAV-SM		
			402MUT-E	452MUT-E	562MUT-E
201	43120225	Fan Ass'y, Turbo	1	1	1
202	43122094	Bell Mouth	1	1	1
203	43172185	Pan Ass'y, Drain	1	1	1
205	43121738	Motor, Fan, SWF-230-60-1R	1	1	1
209	4314J329	Refrigeration, Cycle Ass'y	1	1	1
211	4314Q034	Distributor Ass'y	1	1	1
213	43047685	Nut, Flare, 1/4 IN	1	1	1
215	43149351	Socket, 1/4 IN	1	1	1
216	43047688	Nut, Flare, 1/2 IN	1	1	1
217	43149353	Socket, 1/2 IN	1	1	1
219	43147195	Bonnet, 1/2 IN	1	1	1
220	43049697	Bonnet	1	1	1
221	43170244	Hose, Drain	1	1	1
222	43079249	Band, Hose	1	1	1
223	43060029	Filter, Noise	1	1	1
224	43163052	Holder, Lead, Fan Motor	1	1	1
225	43119482	Cover Ass'y Body	1	1	1
226	43170248	Hose, Drain	1	1	1
227	43119483	Cover, Pipe	1	1	1
228	43097212	Nut	1	1	1
230	43019904	Holder, Sensor	2	2	2
231	43179135	Band, Hose	1	1	1
233	43139137	Rubber, Cushion	3	3	3
234	43162056	Cover, E-Box	1	1	1
235	43177001	Pump, Drain	1	1	1
236	43151289	Switch, Float	1	1	1
237	43179126	Rubber, Pump Drain	3	3	3
238	43166002	Remote Controller, SX-A1EE	—	—	1
239	43166004	Remote Controller, SX-A11JE2	1	1	1
240	43166005	Remote Controller, EX-W2JE2	1	1	1
241	43166006	Remote Controller, WH-H1JE2	1	1	1
242	4318T743	Owner's Manual	—	—	1
247	43197155	Washer	3	3	3
248	43166011	Remote Controller, SX-A4EE	1	1	—
249	431S8127	Owner's Manual	1	1	—

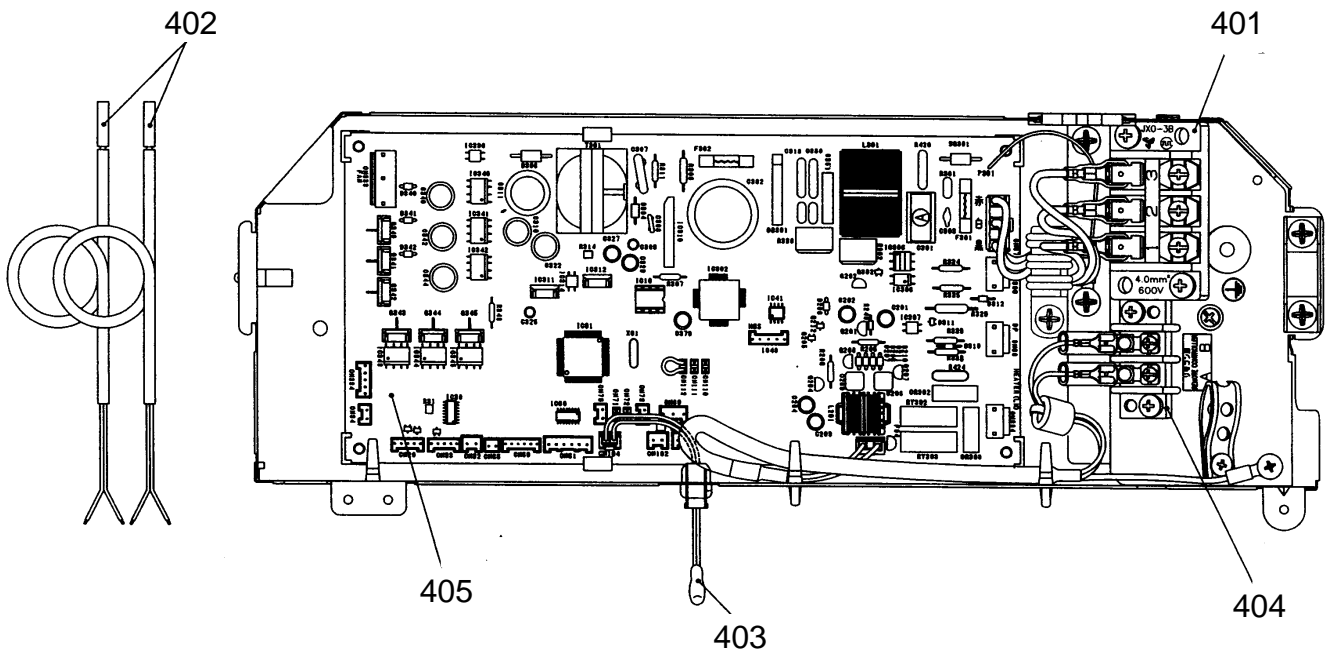

Location No.	Part No.	Description
401	43160565	Terminal Block, 3P, AC250V, 20A,
402	43050425	Sensor Ass'y, Service TC (F6)
403	43050426	Sensor, Service, TA
404	43160568	Terminal, 2P, AC30V/DC42V, 1A
405	4316V323	P.C. Board Ass'y, MMC-1402 (220V – 240V)

WARNINGS ON REFRIGERANT LEAKAGE

Check of Concentration Limit

The room in which the air conditioner is to be installed requires a design that in the event of refrigerant gas leaking out, its concentration will not exceed a set limit.

The refrigerant R410A which is used in the air conditioner is safe, without the toxicity or combustibility of ammonia, and is not restricted by laws to be imposed which protect the ozone layer. However, since it contains more than air, it poses the risk of suffocation if its concentration should rise excessively. Suffocation from leakage of R410A is almost non-existent. With the recent increase in the number of high concentration buildings, however, the installation of multi air conditioner systems is on the increase because of the need for effective use of floor space, individual control, energy conservation by curtailing heat and carrying power etc.

Most importantly, the multi air conditioner system is able to replenish a large amount of refrigerant compared with conventional individual air conditioners. If a single unit of the multi conditioner system is to be installed in a small room, select a suitable model and installation procedure so that if the refrigerant accidentally leaks out, its concentration does not reach the limit (and in the event of an emergency, measures can be made before injury can occur).

In a room where the concentration may exceed the limit, create an opening with adjacent rooms, or install mechanical ventilation combined with a gas leak detection device.

The concentration is as given below.

$$\frac{\text{Total amount of refrigerant (kg)}}{\text{Min. volume of the indoor unit installed room (m}^3\text{)}} \leq \text{Concentration limit (kg/m}^3\text{)}$$

The concentration limit of R410A which is used in multi air conditioners is 0.3kg/m³.

NOTE 1 :

If there are 2 or more refrigerating systems in a single refrigerating device, the amounts of refrigerant should be as charged in each independent device.

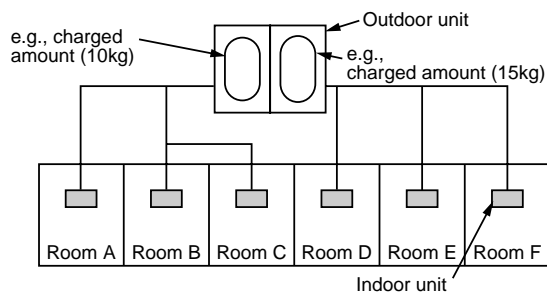

For the amount of charge in this example:

The possible amount of leaked refrigerant gas in rooms A, B and C is 10kg.

The possible amount of leaked refrigerant gas in rooms D, E and F is 15kg.

Important

NOTE 2 :

The standards for minimum room volume are as follows.

- (1) No partition (shaded portion)

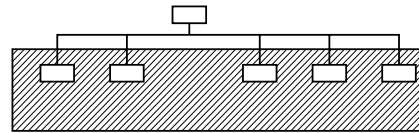

- (2) When there is an effective opening with the adjacent room for ventilation of leaking refrigerant gas (opening without a door, or an opening 0.15% or larger than the respective floor spaces at the top or bottom of the door).

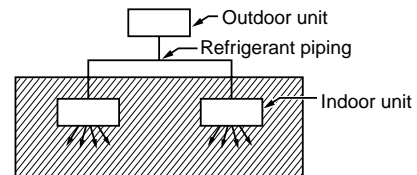

- (3) If an indoor unit is installed in each partitioned room and the refrigerant piping is interconnected, the smallest room of course becomes the object. But when a mechanical ventilation is installed interlocked with a gas leakage detector in the smallest room where the density limit is exceeded, the volume of the next smallest room becomes the object.

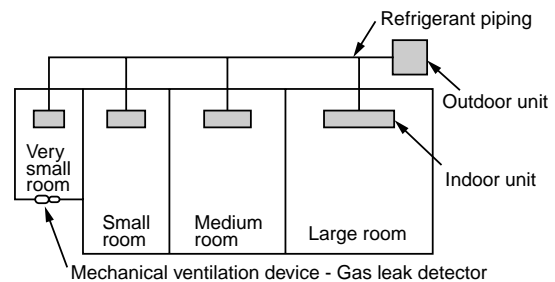

NOTE 3 :

The minimum indoor floor area compared with the amount of refrigerant is roughly as follows:
(When the ceiling is 2.7m high)

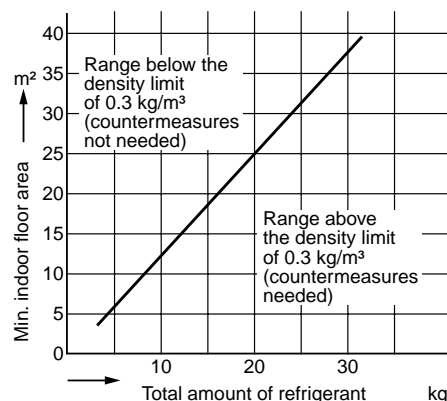

TOSHIBA CARRIER CORPORATION

23-17, TAKANAWA 3 CHOME, MINATOKU, TOKYO, 108-8580, JAPAN

Copyright © 1999 to 2007 TOSHIBA CARRIER CORPORATION, ALL Rights Reserved.