

▶ Static Pressure Fan Coil Units

VHF 01, 05+, 10 & 12

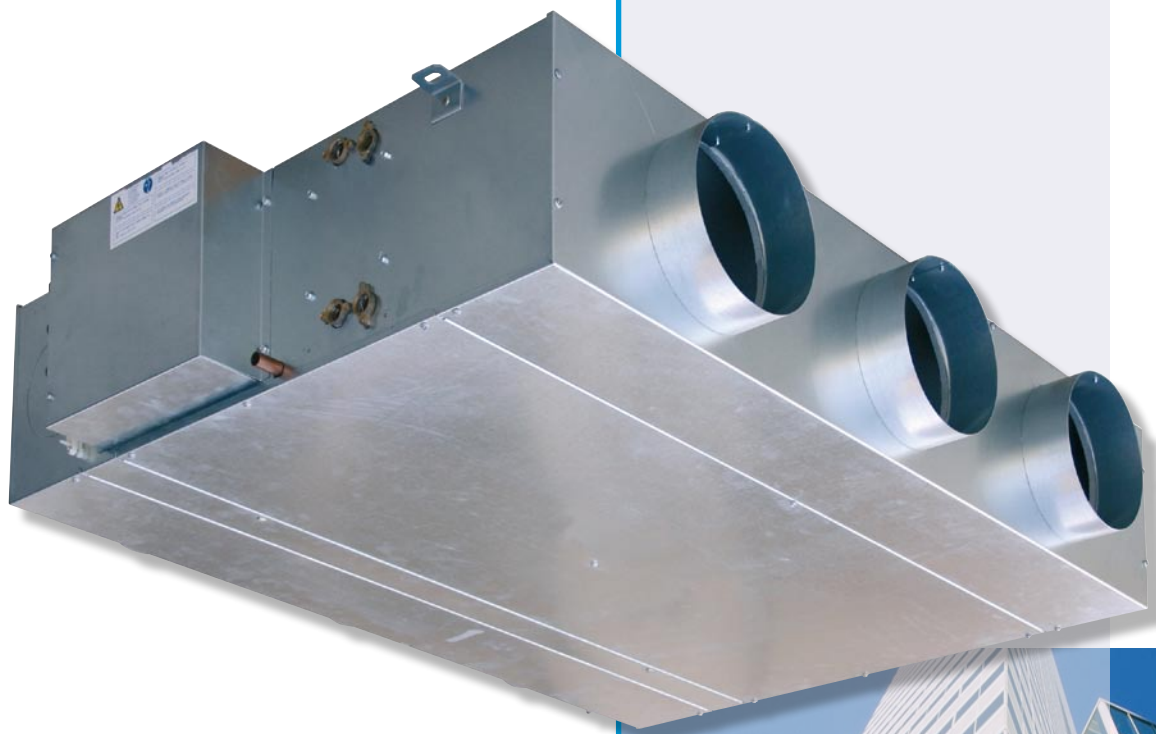

Engineering Data Manual

EDM VHF-W.5GB

Date : January 2008

Supersedes : TM VHF-W.4GB/12.07

Wesper®

Design Features

► Presentation

The VHF fan coil units has been specially designed to meet the job requirements that call for false-ceiling installations and for air distribution by ductwork.

To meet your applications, the VHF fan coil units, composed of 4 sizes, provide 3 types of air ducting configurations.

► Casing

Fabricated from 1.0 mm thick galvanized sheet steel with the fixing brackets located at the top part of the casing for installation to the ceiling.

The VHF fan coil units are available with 3 types of casing configurations :

- Without plenum (SP)
- With supply air plenum (APS)
- With return and supply air plenums (APSA)

The condensate drain pan is made from 1.0 mm thick galvanized sheet steel, painted and is externally insulated by 2 mm thick closed cell polyethylene foam, having M1 fire classification.

An optional auxiliary drain pan can be provided to collect condensates from coils headers.

Access to internal components (fan-motor assembly and coils) for service and maintenance works is facilitated by dismantling the central bottom panel of the fan coil unit, without removing the distribution ducts.

► Integrated plenums

Return and supply air plenums are equipped with 2 or 3 connecting duct collars (having diameter of 160, 200 or 250 mm), according to the unit models.

They are completely integrated into the unit casing.

The supply air plenum is insulated by 10 mm thick closed cell polyethylene foam, having M1 fire classification.

► Fixation

The unit is supplied with 4 slotted fixing brackets as standard.

► Coil compartment

It is lined with 10 mm thick closed cell polyethylene foam insulation, having M1 fire classification.

It incorporates water coils which are fitted with 1/2"Ø female threaded couplings.

The coils of models VHF 01, 05+ & 10 have 4 rows for 2-pipe systems and 3+1 rows for 4-pipe ones. Those of VHF 12 have 5 rows for 2-pipe systems and 4+1 rows for 4-pipe ones.

Coils are leak tested under water (21 bar) and are suitable for a maximum working pressure of 10 bar.

► Fan compartment

It incorporates a fan-motor assembly of which the fan is composed of double inlet forward curved type aluminium wheels and galvanized sheet steel scrolls.

Motor is of direct drive type having 5 or 6 speeds according to the models.

Motor is suitable for nominal voltage of 230 V / 1 Ph / 50 Hz and is equipped with a built-in thermal overload protection of automatic reset type.

► Air filter

Filter consists of cleanable synthetic media having G2 or G3 classification.

Filter is removable and is easily pulled out downward for cleaning or replacement, after removing the access metal plate.

► Options and accessories

→ Electric heater for 2-pipe/2-wire system

Electric heater consists of sheathed type heating elements equipped with a manual reset and an automatic reset high temperature cutout switches.

Standard voltage : Single phase 230 V and three-phase 400 V + Neutral for a capacity higher than 3000 W.

→ Fresh air intakes

The fresh air intake can be realized by using a pre-cut opening Ø100 mm or 125 mm (Ø 100 mm for VHF 01 only) located on the left or right side of the unit.

→ Regulation valves

On/Off (thermal type actuator), 2-way or 4-way type for 2-pipe or 4-pipe systems.

→ Controls

Electromechanical, electronic or digital type.

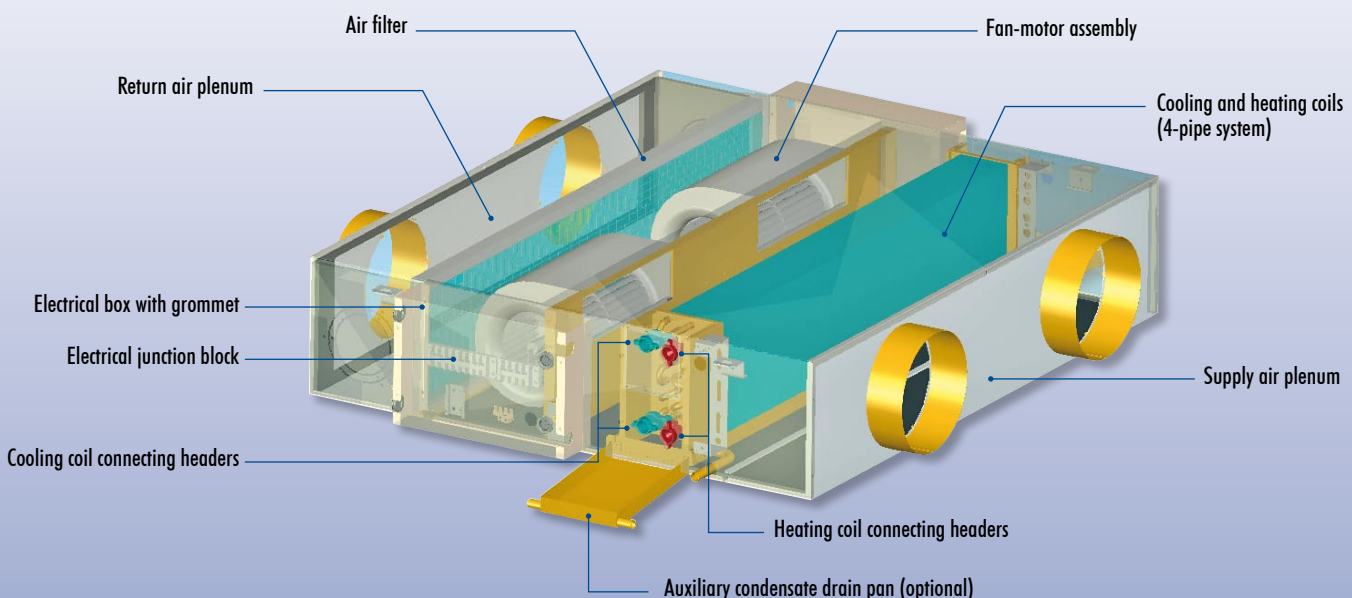

Configurations of VHF

SP Version (without plenum)

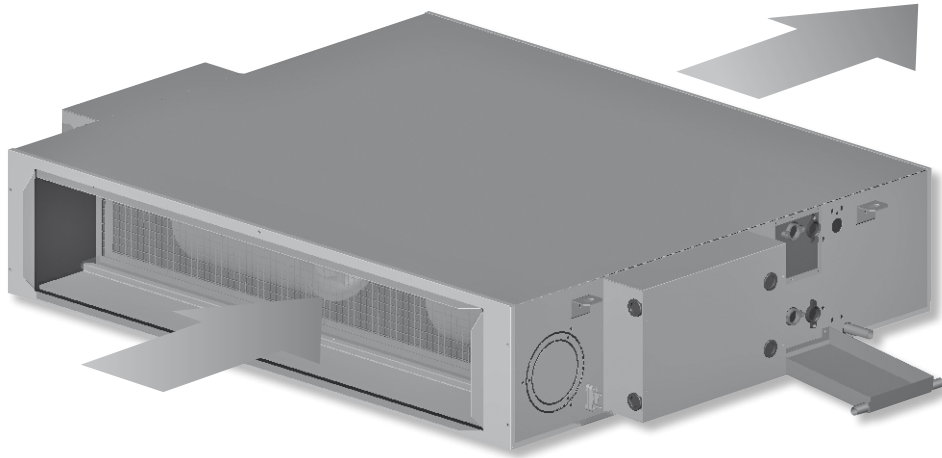

APS Version (with supply air plenum)

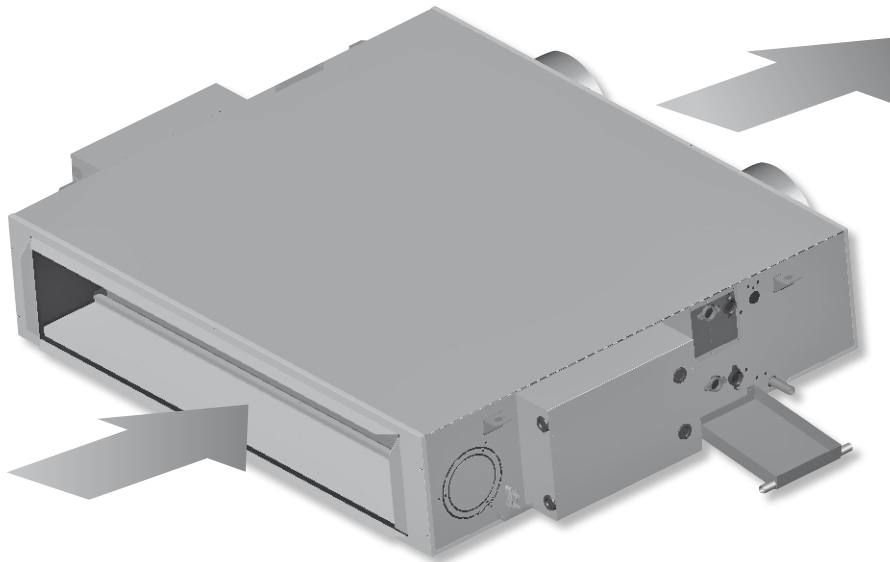

APSA Version (with return and supply air plenums)

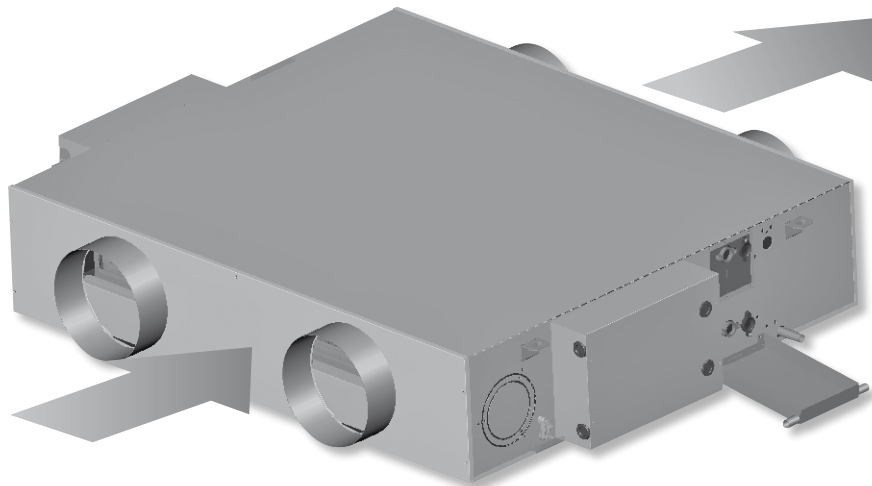

Air Flow Data

VHF 01 - Air Flow m³/h

External static pressure	Plenum	Duct collar	Filter	V1	V2	V3	V4	V5	V6
0 Pa	SP	2 x 160	Without	182	252	329	438	518	615
			G2	175	245	322	429	501	597
			G3	168	237	314	419	485	581
	APS		Without	177	246	325	432	507	604
			G2	172	240	318	424	493	590
			G3	167	234	311	415	476	572
	APSA		Without	162	234	318	436	512	621
			G2	155	225	305	416	486	590
			G3	148	216	293	400	466	570
15 Pa	SP	2 x 160	Without	137	228	314	425	499	599
			G2	166	222	308	417	484	580
			G3	150	216	300	406	469	564
	APS		Without	139	225	310	419	491	587
			G2	164	220	304	411	477	575
			G3	133	215	297	401	462	558
	APSA		Without	124	210	301	421	496	605
			G2	119	202	288	402	470	574
			G3	108	195	278	387	451	554
25 Pa	SP	2 x 160	Without	113	211	304	417	488	589
			G2	124	207	298	408	474	569
			G3	116	201	291	398	460	553
	APS		Without	114	211	300	411	481	577
			G2	123	207	294	402	468	565
			G3	110	202	287	392	453	549
	APSA		Without	95	193	289	412	486	593
			G2	91	185	278	392	460	563
			G3	93	179	268	378	441	544
40 Pa	SP	2 x 160	Without	-	187	289	404	472	573
			G2	-	184	283	396	460	553
			G3	-	180	277	385	446	538
	APS		Without	-	188	285	398	466	561
			G2	-	185	280	390	454	550
			G3	-	181	273	379	440	534
	APSA		Without	-	166	272	397	471	576
			G2	-	160	262	378	445	546
			G3	-	156	254	364	427	527

Air Flow Data (continued)

VHF 05+ - Air Flow m³/h

External static pressure	Plenum	Duct collar	Filter	V1	V2	V3	V4	V5	V6	
0 Pa	SP		Without	489	586	698	819	1015	1357	
			G2	440	528	622	728	897	1144	
			G3	406	483	565	656	799	995	
	APS		2 x 200	Without	434	533	668	781	967	1154
				G2	403	492	598	697	853	1028
				G3	379	456	545	629	762	922
	APSA		2 x 200	Without	418	515	600	678	828	953
				G2	399	486	561	642	774	890
				G3	382	460	530	609	723	836
15 Pa	SP		Without	400	504	617	739	934	1252	
			G2	364	455	551	656	823	1060	
			G3	337	418	500	590	727	912	
	APS		2 x 200	Without	364	461	583	696	874	1069
				G2	340	426	524	621	770	951
				G3	322	397	480	562	687	844
	APSA		2 x 200	Without	359	451	528	615	753	880
				G2	336	422	498	583	701	821
				G3	314	397	468	549	652	767
25 Pa	SP		Without	335	446	560	683	880	1186	
			G2	307	403	500	605	768	999	
			G3	285	370	455	543	674	851	
	APS		2 x 200	Without	315	411	525	637	812	1013
				G2	297	381	474	569	713	894
				G3	282	357	436	516	635	788
	APSA		2 x 200	Without	285	397	484	574	701	829
				G2	263	370	452	539	650	771
				G3	244	347	422	502	602	717
40 Pa	SP		Without	-	347	467	592	790	1082	
			G2	-	315	417	520	677	895	
			G3	-	291	380	466	588	753	
	APS		2 x 200	Without	-	334	436	546	715	923
				G2	-	312	397	489	624	801
				G3	-	295	368	447	555	697
	APSA		2 x 200	Without	-	293	395	497	615	748
				G2	-	272	361	455	565	689
				G3	-	255	332	419	520	635
50 Pa	SP		Without	-	270	397	524	719	1004	
			G2	-	247	355	458	607	817	
			G3	-	231	324	411	525	682	
	APS		2 x 200	Without	-	281	375	483	645	855
				G2	-	265	344	434	561	732
				G3	-	253	321	399	498	632
	APSA		2 x 200	Without	-	201	304	426	551	688
				G2	-	189	275	384	503	629
				G3	-	179	253	351	462	576

Air Flow Data (continued)

VHF 10 - Air Flow m³/h

External static pressure	Plenum	Duct collar	Filter	V1	V2	V3	V4	V5
0 Pa	SP	3 x 200	Without	870	1153	1425	1712	2022
			G2	850	1125	1390	1665	1950
			G3	840	1100	1360	1605	1850
	APS		Without	815	1120	1360	1620	1800
			G2	800	1085	1315	1560	1725
			G3	785	1050	1260	1485	1640
	APSA		Without	800	1050	1300	1475	1690
			G2	785	1025	1245	1405	1580
			G3	770	995	1210	1360	1525
15 Pa	SP	3 x 200	Without	814	1080	1325	1602	1901
			G2	793	1051	1296	1553	1831
			G3	781	1030	1268	1499	1735
	APS		Without	761	1054	1271	1515	1683
			G2	752	1024	1230	1458	1615
			G3	737	987	1175	1382	1536
	APSA		Without	750	986	1214	1383	1587
			G2	737	961	1161	1316	1486
			G3	721	936	1129	1275	1432
25 Pa	SP	3 x 200	Without	774	1033	1271	1538	1822
			G2	752	1005	1244	1488	1753
			G3	741	985	1216	1437	1662
	APS		Without	733	1012	1221	1451	1617
			G2	725	983	1180	1394	1550
			G3	709	945	1124	1317	1471
	APSA		Without	720	946	1162	1325	1519
			G2	707	922	1111	1260	1424
			G3	690	897	1079	1220	1371
40 Pa	SP	3 x 200	Without	710	962	1200	1448	1704
			G2	688	933	1172	1395	1634
			G3	676	915	1145	1350	1550
	APS		Without	694	946	1151	1360	1526
			G2	683	917	1107	1300	1457
			G3	665	876	1049	1220	1375
	APSA		Without	673	885	1087	1239	1418
			G2	659	861	1038	1178	1331
			G3	640	835	1005	1137	1278
50 Pa	SP	3 x 200	Without	664	912	1153	1387	1622
			G2	642	882	1123	1333	1552
			G3	630	864	1096	1289	1473
	APS		Without	662	898	1102	1297	1467
			G2	649	868	1056	1235	1395
			G3	628	826	997	1154	1310
	APSA		Without	637	842	1034	1179	1349
			G2	622	818	987	1121	1267
			G3	600	789	954	1079	1213

Air Flow Data (continued)

VHF 12 - Air Flow m³/h

External static pressure	Plenum	Duct collar	Filter	V1	V2	V3	V4	V5
0 Pa	SP	3 x 250	Without	900	1155	1460	1775	2240
			G2	884	1122	1400	1648	2050
			G3	835	1075	1325	1570	1905
	APS		Without	940	1170	1460	1755	2160
			G2	908	1145	1415	1664	2020
			G3	875	1095	1340	1580	1895
	APSA		Without	908	1160	1430	1670	1975
			G2	900	1142	1390	1602	1875
			G3	860	1090	1325	1535	1800
15 Pa	SP	3 x 250	Without	842	1092	1380	1681	2103
			G2	816	1050	1311	1555	1914
			G3	785	1012	1248	1478	1780
	APS		Without	870	1104	1378	1654	2025
			G2	833	1064	1318	1554	1871
			G3	809	1028	1261	1480	1766
	APSA		Without	857	1099	1350	1574	1854
			G2	835	1071	1303	1502	1750
			G3	807	1032	1253	1444	1677
25 Pa	SP	3 x 250	Without	803	1049	1326	1616	2011
			G2	773	1004	1253	1489	1822
			G3	750	969	1195	1414	1695
	APS		Without	823	1059	1323	1584	1934
			G2	786	1013	1255	1481	1775
			G3	767	983	1207	1411	1679
	APSA		Without	822	1058	1296	1509	1773
			G2	794	1024	1245	1435	1666
			G3	770	991	1201	1381	1595
40 Pa	SP	3 x 250	Without	744	985	1244	1512	1870
			G2	714	936	1166	1387	1685
			G3	696	904	1115	1315	1567
	APS		Without	754	989	1238	1475	1793
			G2	719	939	1163	1370	1632
			G3	704	914	1123	1307	1549
	APSA		Without	766	994	1214	1410	1648
			G2	734	954	1158	1334	1540
			G3	714	924	1119	1283	1471
50 Pa	SP	3 x 250	Without	704	940	1187	1439	1773
			G2	675	890	1109	1316	1593
			G3	659	859	1060	1245	1480
	APS		Without	708	941	1180	1399	1697
			G2	676	890	1103	1296	1539
			G3	662	867	1066	1236	1462
	APSA		Without	727	950	1158	1342	1563
			G2	695	906	1099	1265	1455
			G3	676	877	1061	1215	1388

Electric Heating Coil Data

Sizes		VHF 01	VHF 05+	VHF 10	VHF 12
Capacity (W)	BE1	600	500	1000	1000
	BE2	800	750	1200	1200
	BE3	1200	1000	1500	1500
	BE4	1400	1500	2000	2000
	BE5	1600	2000	2400	2400
	BE6	-	3000	3600*	3600*

(*) Supply voltage is three phase 400 V + Neutral + Earth (power contactor is included).

Fan Motor Electrical Data

Motors absorbed current - 230 V/1 Ph/50 Hz

Sizes		VHF 01		VHF 05+		VHF 10		VHF 12	
		Absorbed current (A)*	Absorbed power (W)*	Absorbed current (A)*	Absorbed power (W)*	Absorbed current (A)*	Absorbed power (W)*	Absorbed current (A)*	Absorbed power (W)*
Fan speed	V1	0.19	40	0.25	57	0.60	132	0.60	132
	V2	0.30	68	0.29	65	0.70	152	0.70	152
	V3	0.44	100	0.33	75	0.80	177	0.80	177
	V4	0.61	138	0.37	81	0.91	205	0.93	210
	V5	0.70	160	0.42	93	1.17	267	1.21	278
	V6	0.85	190	0.60	122	-	-	-	-

(*) Motor maximum absorbed current data given for operation with 230 V/1 Ph/50 Hz power supply and 0 Pa external static pressure for APSA version.

Coil Water Volume

Sizes		VHF 01	VHF 05+	VHF 10	VHF 12
Water volume (litres)	1 row	0.2	0.50	0.60	1.1
	3 rows	0.8	1.6	1.9	3.2
	4 rows	0.90	1.9	2.3	4.2

Note : The 2-pipe system is equipped with 4-row (5-row for VHF 12) coil whereas the 4-pipe system is fitted with 3-row (4-row for VHF 12) and 1 row coils.

Sound Power Levels Lw in dB(A) - VHF 01

Fan speed	Type	Sound power levels by octave band dB(A)						Global dB(A)
		125 Hz	250 Hz	500 Hz	1 kHz	2 kHz	4 kHz	
V1	Return *	23.6	30.9	30.7	30.8	21.4	5.7	36.0
	Discharge *	24.2	29	25.8	33.3	28.6	10.5	36.4
	Radiated **	29.6	27.7	25.0	23.3	17.5	5.7	33.2
V2	Return *	29.9	37.1	37.2	40.6	33.2	10.9	44.0
	Discharge *	31.0	35.4	34.3	38.6	38.6	25.0	43.5
	Radiated **	31.2	30.3	29.7	31.2	25.9	5.7	37.0
V3	Return *	35.1	42.6	42.4	47.5	41.7	27.3	50.4
	Discharge *	36.1	42.3	40.6	45.8	45.2	33.8	50.3
	Radiated **	34.3	34.7	34.3	37.9	32.7	19.0	42.2
V4	Return *	39.7	48.2	48.4	54.2	49.2	35.8	56.9
	Discharge *	41.4	48.3	46.4	52.4	52.1	43.8	56.8
	Radiated **	37.6	40.4	40.2	44.4	39.7	30.4	48.1
V5	Return *	42.1	50.6	51.0	56.9	52.7	40.0	59.8
	Discharge *	43.7	51.0	49.9	56.9	55.2	48.1	60.6
	Radiated **	39.3	43	43.3	47.9	43.1	34.1	51.3
V6	Return *	45.3	53.7	54.4	60.7	57.0	45.0	63.6
	Discharge *	47.6	54.6	54.3	60.5	60.5	53.1	64.9
	Radiated **	42.4	45.8	46.5	50.7	47.6	39.3	54.5

(*) Data given for APSA version and 0 Pa external static pressure.

(**) Data given for APSA version and 50 Pa external static pressure at High Speed.

Sound Power Levels Lw in dB(A) - VHF 05+

Fan speed	Type	Sound power levels by octave band dB(A)						Global dB(A)
		125 Hz	250 Hz	500 Hz	1 kHz	2 kHz	4 kHz	
V1	Return *	35.7	33.7	36.2	32.9	25.2	5.7	41.0
	Discharge *	35.1	31.9	33.9	32.5	26.4	16.3	39.8
	Radiated **	28.0	28.1	29.4	27.0	21.7	5.7	34.5
V2	Return *	38.3	38.3	38.2	36.9	30.8	17.5	44.2
	Discharge *	37.7	34.6	37.6	36.4	30.8	14.5	43.1
	Radiated **	32.1	31.5	33.3	31.5	29.7	12.6	38.8
V3	Return *	39.6	38.2	39.3	39.2	34.6	25.3	45.5
	Discharge *	39.2	38	39.6	39.6	35.9	25.2	45.7
	Radiated **	34.8	34.9	37.9	35.2	29.3	24.9	42.3
V4	Return *	42.7	42.5	44.4	44.1	41.5	30.4	50.2
	Discharge *	41.4	41.3	43.0	43.9	39.7	26.1	49.1
	Radiated **	37.1	38.6	39.4	38.0	35.0	26.0	44.9
V5	Return *	45.6	45.1	46.9	46.9	43.6	34.7	52.8
	Discharge *	44.6	44.7	46.3	47.6	44.4	31.4	52.7
	Radiated **	39.6	39.8	41.9	40.8	35.7	27.2	47.1
V6	Return *	49.1	50.0	50.4	51.1	47.6	39.5	56.9
	Discharge *	46.9	48.8	50.0	52.3	47.2	35.2	56.5
	Radiated **	42.6	43.1	44.1	44.9	40.5	31.4	50.3

(*) Data given for APSA version and 0 Pa external static pressure.

(**) Data given for APSA version and 50 Pa external static pressure at High Speed.

Sound Power Levels Lw in dB(A) - VHF 10

Fan speed	Type	Sound power levels by octave band dB(A)						Global dB(A)
		125 Hz	250 Hz	500 Hz	1 kHz	2 kHz	4 kHz	
V1	Return *	38.2	42.3	41.1	37.6	36.8	26.1	46.8
	Discharge *	38.4	41.7	41.9	42.5	38.0	24.6	47.9
	Radiated **	35.5	36.1	38.2	38.0	33.1	24.9	43.6
V2	Return *	46.7	50.4	49.3	47.9	46.9	38.2	55.6
	Discharge *	44.7	47.7	47.7	48.8	45.8	36.6	54.2
	Radiated **	41.6	42.0	43.8	41.6	34.8	27.8	48.6
V3	Return *	51.3	54.7	53.6	52.8	52.1	45.0	60.2
	Discharge *	50.0	53.3	53.4	54.7	50.9	41.3	59.9
	Radiated **	45.1	45.3	47.3	45.4	39.9	33.5	52.2
V4	Return *	54.6	58.4	56.4	56.3	55.0	48.2	63.5
	Discharge *	52.9	56.1	56.6	58.2	53.5	43.9	62.9
	Radiated **	46.6	47.3	49.4	47.4	42.2	37.6	54.2
V5	Return *	56.6	60.5	58.4	58.8	57.4	51.8	65.7
	Discharge *	55.3	58.4	58.7	61.1	55.8	46.4	65.4
	Radiated **	47.7	48.9	51.0	49.1	44.1	38.0	55.8

(*) Data given for APSA version and 0 Pa external static pressure.

(**) Data given for APSA version and 50 Pa external static pressure at High Speed.

Sound Power Levels Lw in dB(A) - VHF 12

Fan speed	Type	Sound power levels by octave band dB(A)						Global dB(A)
		125 Hz	250 Hz	500 Hz	1 kHz	2 kHz	4 kHz	
V1	Return *	37.8	43.4	44.9	43.2	39.8	29.6	49.5
	Discharge *	36.2	39.5	45.4	43.5	42.5	28.1	49.5
	Radiated **	31.9	37.6	41.1	40.2	37.1	35.3	46
V2	Return *	42.3	47.2	49.7	47.4	45.1	36.9	54.1
	Discharge *	40.8	44.2	46.2	48.3	48.3	40.4	53.6
	Radiated **	35.2	39.9	44.6	43.8	41.5	32.1	49.1
V3	Return *	46.1	50.9	51.4	50.9	49.6	42.3	57.3
	Discharge *	44.9	48.6	49.6	52.6	51.4	42.3	57.2
	Radiated **	37.6	42.9	46.8	46.6	44.1	36.5	51.7
V4	Return *	49.1	53.9	54.0	53.4	52.6	46.0	60.1
	Discharge *	47.5	51.4	52.4	55.3	54.0	45.8	60.0
	Radiated **	40.2	45.4	48.7	48.5	46.4	27.5	53.8
V5	Return *	51.5	57.1	55.6	56.9	54.4	46.5	62.6
	Discharge *	50.1	54.6	55.2	59.2	56.4	49	63.2
	Radiated **	41.9	47.1	50.2	50.9	48.0	40.7	55.7

(*) Data given for APSA version and 0 Pa external static pressure.

(**) Data given for APSA version and 50 Pa external static pressure at High Speed.

Cooling Capacities - VHF 01 - 2-pipe system

Fan speed				V1	V2	V3	V4	V5	V6
Air flow (m ³ /h)				76	177	272	388	455	557
5/10 °C	27 °C	Pt	W	650	1430	2199	2875	3217	3886
	50%	Ps	W	415	922	1433	1866	2079	2537
	25 °C	Pt	W	535	1112	1730	2250	2518	3051
	50%	Ps	W	364	780	1226	1593	1773	2177
	23 °C	Pt	W	433	874	1348	1744	1945	2367
	50%	Ps	W	319	674	1057	1371	1522	1875
6/11 °C	27 °C	Pt	W	597	1289	1993	2598	2904	3514
	50%	Ps	W	387	850	1328	1727	1924	2351
	25 °C	Pt	W	483	994	1555	2012	2245	2727
	50%	Ps	W	338	722	1144	1480	1645	2021
	23 °C	Pt	W	391	788	1185	1534	1711	2086
	50%	Ps	W	298	633	981	1272	1412	1742
7/12 °C	27 °C	Pt	W	543	1151	1782	2320	2592	3142
	50%	Ps	W	359	782	1230	1596	1778	2180
	25 °C	Pt	W	438	879	1380	1783	1987	2417
	50%	Ps	W	315	668	1062	1376	1526	1880
	23 °C	Pt	W	349	706	1030	1338	1494	1824
	50%	Ps	W	277	595	910	1184	1314	1625
8/13 °C	27 °C	Pt	W	490	1026	1598	2065	2303	2795
	50%	Ps	W	334	725	1146	1483	1647	2026
	25 °C	Pt	W	393	790	1209	1562	1741	2120
	50%	Ps	W	295	629	985	1277	1416	1749
	23 °C	Pt	W	310	630	890	1163	1300	1590
	50%	Ps	W	259	560	849	1107	1227	1522
10/15 °C	27 °C	Pt	W	396	791	1231	1588	1768	2151
	50%	Ps	W	292	624	989	1281	1420	1755
	25 °C	Pt	W	309	627	903	1177	1314	1606
	50%	Ps	W	257	559	857	1115	1237	1536
	23 °C	Pt	W	241	500	713	892	1002	1228
	50%	Ps	W	228	448	713	892	1002	1228

Note : Cooling capacities are given for APSA version with G2 air filter and 30 Pa external static pressure. Airflows given for dry coil.

Cooling Capacities - VHF 01 - 4-pipe system

Fan speed				V1	V2	V3	V4	V5	V6
Air flow (m ³ /h)				76	177	272	388	455	557
5/10 °C	27 °C	Pt	W	562	1215	1870	2468	2877	3314
	50%	Ps	W	367	803	1239	1650	1941	2253
	25 °C	Pt	W	457	929	1447	1913	2239	2582
	50%	Ps	W	323	680	1058	1417	1672	1949
	23 °C	Pt	W	366	761	1103	1463	1718	1980
	50%	Ps	W	283	609	909	1222	1449	1687
6/11 °C	27 °C	Pt	W	513	1085	1678	2217	2589	2984
	50%	Ps	W	343	741	1149	1534	1806	2100
	25 °C	Pt	W	412	845	1287	1701	1993	2297
	50%	Ps	W	301	642	984	1320	1559	1817
	23 °C	Pt	W	329	685	963	1281	1507	1738
	50%	Ps	W	265	574	846	1139	1352	1579
7/12 °C	27 °C	Pt	W	464	961	1494	1973	2307	2661
	50%	Ps	W	320	685	1065	1423	1680	1958
	25 °C	Pt	W	369	764	1131	1497	1756	2022
	50%	Ps	W	282	605	916	1230	1458	1699
	23 °C	Pt	W	293	614	852	1116	1316	1519
	50%	Ps	W	249	542	796	1066	1269	1484
8/13 °C	27 °C	Pt	W	416	852	1324	1747	2045	2355
	50%	Ps	W	299	637	989	1326	1568	1831
	25 °C	Pt	W	331	686	984	1305	1534	1768
	50%	Ps	W	264	571	852	1148	1364	1594
	23 °C	Pt	W	260	548	765	954	1126	1304
	50%	Ps	W	234	512	759	954	1126	1304
10/15 °C	27 °C	Pt	W	332	686	1004	1328	1559	1795
	50%	Ps	W	263	569	860	1156	1373	1607
	25 °C	Pt	W	259	546	763	968	1138	1319
	50%	Ps	W	233	513	762	968	1138	1319
	23 °C	Pt	W	200	438	623	773	893	1038
	50%	Ps	W	200	438	623	773	893	1038

Note : Cooling capacities are given for APSA version with G2 air filter and 30 Pa external static pressure. Airflows given for dry coil.

Cooling Capacities - VHF 05+ - 2-pipe system

Fan speed				V1	V2	V3	V4	V5	V6
Air flow (m ³ /h)				-	189	275	384	503	629
5/10 °C	27 °C	Pt	W	-	1797	2581	3500	4414	5283
	50%	Ps	W	-	1168	1679	2284	2885	3469
	25 °C	Pt	W	-	1432	2057	2798	3516	4209
	50%	Ps	W	-	1007	1450	1977	2503	3002
	23 °C	Pt	W	-	1181	1615	2194	2747	3274
	50%	Ps	W	-	898	1249	1708	2161	2591
6/11 °C	27 °C	Pt	W	-	1642	2362	3197	4021	4813
	50%	Ps	W	-	1087	1567	2132	2694	3232
	25 °C	Pt	W	-	1310	1864	2513	3143	3748
	50%	Ps	W	-	946	1352	1837	2317	2782
	23 °C	Pt	W	-	1071	1414	1939	2436	2902
	50%	Ps	W	-	843	1152	1588	2009	2415
7/12 °C	27 °C	Pt	W	-	1490	2132	2885	3626	4336
	50%	Ps	W	-	1013	1453	1981	2503	3001
	25 °C	Pt	W	-	1193	1664	2250	2811	3349
	50%	Ps	W	-	890	1256	1713	2165	2595
	23 °C	Pt	W	-	961	1253	1688	2129	2542
	50%	Ps	W	-	790	1079	1469	1868	2247
8/13 °C	27 °C	Pt	W	-	1339	1922	2583	3227	3846
	50%	Ps	W	-	943	1356	1840	2321	2786
	25 °C	Pt	W	-	1076	1455	1982	2482	2955
	50%	Ps	W	-	836	1164	1592	2016	2420
	23 °C	Pt	W	-	853	1116	1448	1841	2206
	50%	Ps	W	-	741	1017	1362	1740	2097
10/15 °C	27 °C	Pt	W	-	1082	1494	2022	2526	3005
	50%	Ps	W	-	829	1168	1597	2021	2424
	25 °C	Pt	W	-	852	1112	1472	1862	2226
	50%	Ps	W	-	736	1014	1374	1753	2112
	23 °C	Pt	W	-	665	872	1110	1369	1655
	50%	Ps	W	-	656	872	1110	1369	1655

Note : Cooling capacities are given for APSA version with G2 air filter and 50 Pa external static pressure. Airflows given for dry coil.

Cooling Capacities - VHF 05+ - 4-pipe system

Fan speed				V1	V2	V3	V4	V5	V6
Air flow (m ³ /h)				-	189	275	384	503	629
5/10 °C	27 °C	Pt	W	-	1723	2451	3299	4130	4925
	50%	Ps	W	-	1125	1593	2133	2674	3192
	25 °C	Pt	W	-	1375	1939	2613	3272	3896
	50%	Ps	W	-	975	1369	1830	2285	2739
	23 °C	Pt	W	-	1138	1517	2045	2550	3028
	50%	Ps	W	-	872	1179	1576	1967	2359
6/11 °C	27 °C	Pt	W	-	1566	2232	3003	3756	4467
	50%	Ps	W	-	1046	1482	1981	2473	2965
	25 °C	Pt	W	-	1263	1752	2350	2928	3476
	50%	Ps	W	-	919	1277	1699	2116	2533
	23 °C	Pt	W	-	1030	1341	1803	2253	2677
	50%	Ps	W	-	819	1096	1462	1824	2188
7/12 °C	27 °C	Pt	W	-	1418	2005	2697	3369	4010
	50%	Ps	W	-	975	1371	1832	2289	2743
	25 °C	Pt	W	-	1148	1560	2095	2609	3096
	50%	Ps	W	-	866	1186	1580	1968	2359
	23 °C	Pt	W	-	923	1203	1569	1968	2340
	50%	Ps	W	-	769	1030	1354	1691	2035
8/13 °C	27 °C	Pt	W	-	1280	1806	2415	3006	3568
	50%	Ps	W	-	911	1280	1701	2118	2538
	25 °C	Pt	W	-	1035	1364	1840	2295	2722
	50%	Ps	W	-	813	1097	1467	1827	2195
	23 °C	Pt	W	-	820	1071	1352	1705	2033
	50%	Ps	W	-	722	972	1256	1574	1900
10/15 °C	27 °C	Pt	W	-	1039	1396	1875	2335	2765
	50%	Ps	W	-	807	1103	1470	1828	2200
	25 °C	Pt	W	-	818	1067	1372	1724	2052
	50%	Ps	W	-	718	970	1265	1584	1912
	23 °C	Pt	W	-	641	839	1066	1287	1546
	50%	Ps	W	-	641	839	1066	1287	1546

Note : Cooling capacities are given for APSA version with G2 air filter and 50 Pa external static pressure. Airflows given for dry coil.

Cooling Capacities - VHF 10 - 2-pipe system

Fan speed				V1	V2	V3	V4	V5
Air flow (m ³ /h)				622	818	987	1121	1267
5/10 °C	27 °C	Pt	W	4405	5863	7123	8136	9103
	50%	Ps	W	2768	3719	4636	5270	5917
	25 °C	Pt	W	3420	4590	5601	6418	7236
	50%	Ps	W	2313	3146	3979	4522	5123
	23 °C	Pt	W	2583	3508	4309	4957	5606
	50%	Ps	W	1927	2663	3408	3877	4402
6/11 °C	27 °C	Pt	W	3963	5293	6444	7364	8276
	50%	Ps	W	2533	3421	4295	4890	5515
	25 °C	Pt	W	3015	4062	4973	5702	6442
	50%	Ps	W	2103	2892	3675	4184	4736
	23 °C	Pt	W	2252	3081	3797	4374	4953
	50%	Ps	W	1766	2457	3167	3601	4089
7/12 °C	27 °C	Pt	W	3421	4597	5643	6502	7361
	50%	Ps	W	2253	3007	3887	4437	5035
	25 °C	Pt	W	2651	3589	4403	5061	5724
	50%	Ps	W	1931	2665	3419	3886	4406
	23 °C	Pt	W	1940	2680	3314	3824	4334
	50%	Ps	W	1621	2271	2947	3349	3811
8/13 °C	27 °C	Pt	W	3103	4172	5102	5848	6605
	50%	Ps	W	2106	2889	3680	4186	4740
	25 °C	Pt	W	2303	3138	3862	4446	5031
	50%	Ps	W	1773	2463	3177	3609	4100
	23 °C	Pt	W	1685	2318	2878	3325	3774
	50%	Ps	W	1507	2109	2721	3135	3564
10/15 °C	27 °C	Pt	W	2350	3192	3923	4513	5105
	50%	Ps	W	1775	2464	3186	3617	4108
	25 °C	Pt	W	1696	2347	2905	3354	3804
	50%	Ps	W	1512	2123	2779	3154	3586
	23 °C	Pt	W	1359	1755	2193	2537	2886
	50%	Ps	W	1332	1755	2193	2537	2886

Note : Cooling capacities are given for APSA version with G2 air filter and 50 Pa external static pressure. Airflows given for dry coil.

Cooling Capacities - VHF 10 - 4-pipe system

Fan speed				V1	V2	V3	V4	V5
Air flow (m ³ /h)				622	818	987	1121	1267
5/10 °C	27 °C	Pt	W	4174	5362	6400	7244	8123
	50%	Ps	W	2690	3481	4169	4694	5292
	25 °C	Pt	W	3269	4218	5060	5778	6503
	50%	Ps	W	2292	2985	3600	4065	4609
	23 °C	Pt	W	2493	3241	3904	4470	5061
	50%	Ps	W	1952	2555	3090	3489	3977
6/11 °C	27 °C	Pt	W	3764	4844	5800	6582	7381
	50%	Ps	W	2485	3224	3879	4360	4932
	25 °C	Pt	W	2898	3751	4508	5153	5824
	50%	Ps	W	2117	2765	3334	3766	4290
	23 °C	Pt	W	2188	2852	3441	3942	4469
	50%	Ps	W	1808	2374	2872	3244	3696
7/12 °C	27 °C	Pt	W	3269	4276	5156	5897	6627
	50%	Ps	W	2210	2938	3544	3987	4529
	25 °C	Pt	W	2551	3309	3984	4560	5160
	50%	Ps	W	1954	2564	3098	3494	3985
	23 °C	Pt	W	1902	2488	3007	3450	3913
	50%	Ps	W	1678	2211	2679	3019	3448
8/13 °C	27 °C	Pt	W	2973	3843	4617	5279	5946
	50%	Ps	W	2117	2767	3338	3762	4283
	25 °C	Pt	W	2228	2898	3493	4002	4533
	50%	Ps	W	1813	2382	2883	3248	3707
	23 °C	Pt	W	1646	2161	2617	3006	3412
	50%	Ps	W	1565	2070	2505	2824	3229
10/15 °C	27 °C	Pt	W	2264	2941	3544	4059	4596
	50%	Ps	W	1820	2390	2888	3251	3712
	25 °C	Pt	W	1665	2180	2636	3026	3433
	50%	Ps	W	1580	2084	2527	2840	3248
	23 °C	Pt	W	1246	1643	1998	2295	2606
	50%	Ps	W	1246	1643	1998	2295	2606

Note : Cooling capacities are given for APSA version with G2 air filter and 50 Pa external static pressure. Airflows given for dry coil.

Cooling Capacities - VHF 12 - 2-pipe system

Fan speed				V1	V2	V3	V4	V5
Air flow (m ³ /h)				695	906	1099	1265	1455
5/10 °C	27 °C	Pt	W	6178	7877	9285	10419	11627
	50%	Ps	W	3963	5081	5999	6752	7555
	25 °C	Pt	W	4911	6277	7385	8282	9240
	50%	Ps	W	3392	4369	5170	5825	6513
	23 °C	Pt	W	3790	4861	5714	6405	7147
	50%	Ps	W	2884	3732	4425	4992	5581
6/11 °C	27 °C	Pt	W	5636	7182	8451	9470	10573
	50%	Ps	W	3673	4719	5575	6282	7018
	25 °C	Pt	W	4359	5589	6572	7372	8229
	50%	Ps	W	3119	4027	4780	5391	6030
	23 °C	Pt	W	3339	4302	5063	5675	6330
	50%	Ps	W	2664	3464	4113	4647	5199
7/12 °C	27 °C	Pt	W	5061	6468	7593	8518	9498
	50%	Ps	W	3398	4366	5173	5823	6512
	25 °C	Pt	W	3890	4972	5843	6547	7297
	50%	Ps	W	2891	3741	4432	4999	5595
	23 °C	Pt	W	2890	3755	4427	4967	5544
	50%	Ps	W	2456	3211	3822	4326	4844
8/13 °C	27 °C	Pt	W	4493	5739	6743	7566	8435
	50%	Ps	W	3118	4031	4780	5387	6031
	25 °C	Pt	W	3417	4388	5153	5773	6432
	50%	Ps	W	2674	3469	4122	4656	5214
	23 °C	Pt	W	2507	3240	3836	4312	4818
	50%	Ps	W	2283	2978	3557	4032	4520
10/15 °C	27 °C	Pt	W	3488	4468	5239	5866	6538
	50%	Ps	W	2682	3474	4129	4664	5214
	25 °C	Pt	W	2512	3280	3873	4350	4858
	50%	Ps	W	2286	2998	3577	4054	4541
	23 °C	Pt	W	1975	2417	2862	3232	3627
	50%	Ps	W	1975	2417	2862	3232	3627

Note : Cooling capacities are given for APSA version with G2 air filter and 50 Pa external static pressure. Airflows given for dry coil.

Cooling Capacities - VHF 12 - 4-pipe system

Fan speed				V1	V2	V3	V4	V5
Air flow (m ³ /h)				695	906	1099	1265	1455
5/10 °C	27 °C	Pt	W	5395	6819	7963	8872	9866
	50%	Ps	W	3539	4499	5280	5903	6600
	25 °C	Pt	W	4174	5310	6213	6933	7721
	50%	Ps	W	3013	3858	4544	5091	5705
	23 °C	Pt	W	3147	4043	4743	5299	5913
	50%	Ps	W	2558	3299	3897	4378	4912
6/11 °C	27 °C	Pt	W	4859	6153	7181	8002	8901
	50%	Ps	W	3281	4176	4913	5496	6148
	25 °C	Pt	W	3691	4697	5497	6135	6844
	50%	Ps	W	2782	3567	4205	4725	5300
	23 °C	Pt	W	2729	3534	4157	4649	5190
	50%	Ps	W	2365	3060	3629	4083	4586
7/12 °C	27 °C	Pt	W	4321	5484	6405	7143	7953
	50%	Ps	W	3030	3868	4563	5107	5717
	25 °C	Pt	W	3245	4148	4856	5422	6043
	50%	Ps	W	2580	3321	3928	4407	4948
	23 °C	Pt	W	2444	3051	3606	4041	4518
	50%	Ps	W	2240	2846	3389	3814	4296
8/13 °C	27 °C	Pt	W	3807	4834	5648	6303	7024
	50%	Ps	W	2800	3583	4229	4746	5329
	25 °C	Pt	W	2805	3614	4240	4736	5283
	50%	Ps	W	2391	3091	3659	4110	4621
	23 °C	Pt	W	2182	2528	3106	3329	3724
	50%	Ps	W	2127	2528	2051	3329	3724
10/15 °C	27 °C	Pt	W	2877	3687	4318	4818	5369
	50%	Ps	W	2412	3111	3679	4135	4653
	25 °C	Pt	W	2175	2542	2999	3359	3760
	50%	Ps	W	2130	2542	2999	3359	3760
	23 °C	Pt	W	1745	2108	2384	2657	2990
	50%	Ps	W	1745	2108	2384	2657	2990

Note : Cooling capacities are given for APSA version with G2 air filter and 50 Pa external static pressure. Airflows given for dry coil.

Heating Capacities - VHF 01 - 2-pipe system

Fan speed				V1	V2	V3	V4	V5	V6
Air flow (m³/h)				76	177	272	388	455	557
80/60 °C	19 °C	PC	W	1131	2596	3954	5119	5852	6858
	20 °C	PC	W	1107	2542	3872	5013	5731	6714
	21 °C	PC	W	1083	2488	3790	4908	5609	6571
70/50 °C	19 °C	PC	W	920	2066	3154	4068	4659	5466
	20 °C	PC	W	898	2010	3070	3959	4533	5318
	21 °C	PC	W	875	1954	2985	3848	4406	5169
50/40 °C	19 °C	PC	W	586	1315	2008	2592	2969	3485
	20 °C	PC	W	563	1260	1924	2484	2845	3340
	21 °C	PC	W	541	1204	1842	2375	2720	3192

Heating Capacities - VHF 01 - 4-pipe system

Fan speed				V1	V2	V3	V4	V5	V6
Air flow (m³/h)				76	177	272	388	455	557
80/60 °C	19 °C	PC	W	862	1778	2460	3109	3453	3877
	20 °C	PC	W	842	1737	2405	3037	3374	3787
	21 °C	PC	W	823	1695	2349	2966	3294	3699
70/50 °C	19 °C	PC	W	657	1348	1862	2366	2635	2956
	20 °C	PC	W	636	1306	1804	2291	2553	2866
	21 °C	PC	W	617	1264	1745	2216	2470	2777
50/40 °C	19 °C	PC	W	422	868	1199	1525	1700	1908
	20 °C	PC	W	402	827	1142	1452	1619	1818
	21 °C	PC	W	385	785	1084	1378	1536	1730

Heating Capacities - VHF 05+ - 2-pipe system

Fan speed				V1	V2	V3	V4	V5	V6
Air flow (m³/h)				-	189	273	384	503	629
80/60 °C	19 °C	PC	W	-	3273	4629	6271	7970	9716
	20 °C	PC	W	-	3209	4538	6147	7813	9523
	21 °C	PC	W	-	3146	4447	6024	7656	9331
70/50 °C	19 °C	PC	W	-	2673	3775	5103	6480	7906
	20 °C	PC	W	-	2605	3681	4974	6318	7707
	21 °C	PC	W	-	2538	3587	4847	6155	7508
50/40 °C	19 °C	PC	W	-	1693	2393	3236	4111	5018
	20 °C	PC	W	-	1626	2300	3110	3950	4821
	21 °C	PC	W	-	1560	2206	2983	3789	4623

Heating Capacities - VHF 05+ - 4-pipe system

Fan speed				V1	V2	V3	V4	V5	V6
Air flow (m³/h)				-	189	273	384	503	629
80/60 °C	19 °C	PC	W	-	2720	3675	4716	5642	6394
	20 °C	PC	W	-	2665	3600	4619	5523	6259
	21 °C	PC	W	-	2610	3524	4520	5406	6124
70/50 °C	19 °C	PC	W	-	2188	2953	3769	4488	5068
	20 °C	PC	W	-	2130	2876	3671	4370	4933
	21 °C	PC	W	-	2074	2800	3571	4250	4797
50/40 °C	19 °C	PC	W	-	1391	1879	2401	2862	3234
	20 °C	PC	W	-	1335	1804	2304	2745	3101
	21 °C	PC	W	-	1278	1729	2207	2628	2968

Heating Capacities - VHF 10 - 2-pipe system

Fan speed				V1	V2	V3	V4	V5
Air flow (m³/h)				622	818	987	1121	1267
80/60 °C	19 °C	PC	W	5990	8102	9787	11355	12847
	20 °C	PC	W	5862	7929	9584	11119	12576
	21 °C	PC	W	5733	7757	9378	10881	12311
70/50 °C	19 °C	PC	W	4695	6378	7721	8993	10204
	20 °C	PC	W	4564	6201	7510	8750	9926
	21 °C	PC	W	4433	6026	7300	8505	9648
50/40 °C	19 °C	PC	W	2997	4070	4925	5736	6506
	20 °C	PC	W	2868	3895	4718	5496	6235
	21 °C	PC	W	2738	3723	4508	5255	5962

Heating Capacities - VHF 10 - 4-pipe system

Fan speed				V1	V2	V3	V4	V5
Air flow (m³/h)				622	818	987	1121	1267
80/60 °C	19 °C	PC	W	4982	6701	7719	8812	9827
	20 °C	PC	W	4877	6560	7556	8625	9618
	21 °C	PC	W	4772	6418	7393	8441	9410
70/50 °C	19 °C	PC	W	3946	5303	6100	6963	7758
	20 °C	PC	W	3841	5162	5938	6775	7551
	21 °C	PC	W	3736	5022	5774	6588	7341
50/40 °C	19 °C	PC	W	2519	3387	3898	4449	4958
	20 °C	PC	W	2415	3247	3736	4263	4751
	21 °C	PC	W	2313	3108	3575	4080	4546

Heating Capacities - VHF 12 - 2-pipe system

Fan speed				V1	V2	V3	V4	V5
Air flow (m³/h)				695	906	1099	1265	1455
80/60 °C	19 °C	PC	W	11625	14952	17779	20126	22790
	20 °C	PC	W	11397	14662	17431	19732	22342
	21 °C	PC	W	11170	14372	17084	19337	21892
70/50 °C	19 °C	PC	W	9504	12223	14537	16452	18596
	20 °C	PC	W	9270	11922	14178	16048	18137
	21 °C	PC	W	9035	11623	13816	15641	17682
50/40 °C	19 °C	PC	W	6021	7747	9216	10434	11797
	20 °C	PC	W	5790	7449	8861	10030	11346
	21 °C	PC	W	5558	7150	8505	9625	10893

Heating Capacities - VHF 12 - 4-pipe system

Fan speed				V1	V2	V3	V4	V5
Air flow (m³/h)				695	906	1099	1265	1455
80/60 °C	19 °C	PC	W	5006	6224	7240	8084	8995
	20 °C	PC	W	4902	6092	7086	7913	8804
	21 °C	PC	W	4796	5961	6933	7742	8612
70/50 °C	19 °C	PC	W	3926	4903	5711	6372	7083
	20 °C	PC	W	3817	4767	5557	6199	6893
	21 °C	PC	W	3708	4631	5402	6029	6699
50/40 °C	19 °C	PC	W	2508	3134	3650	4074	4530
	20 °C	PC	W	2402	3001	3499	3906	4341
	21 °C	PC	W	2294	2867	3344	3735	4153

Water Pressure Drops - Cooling Mode - 2-pipe system

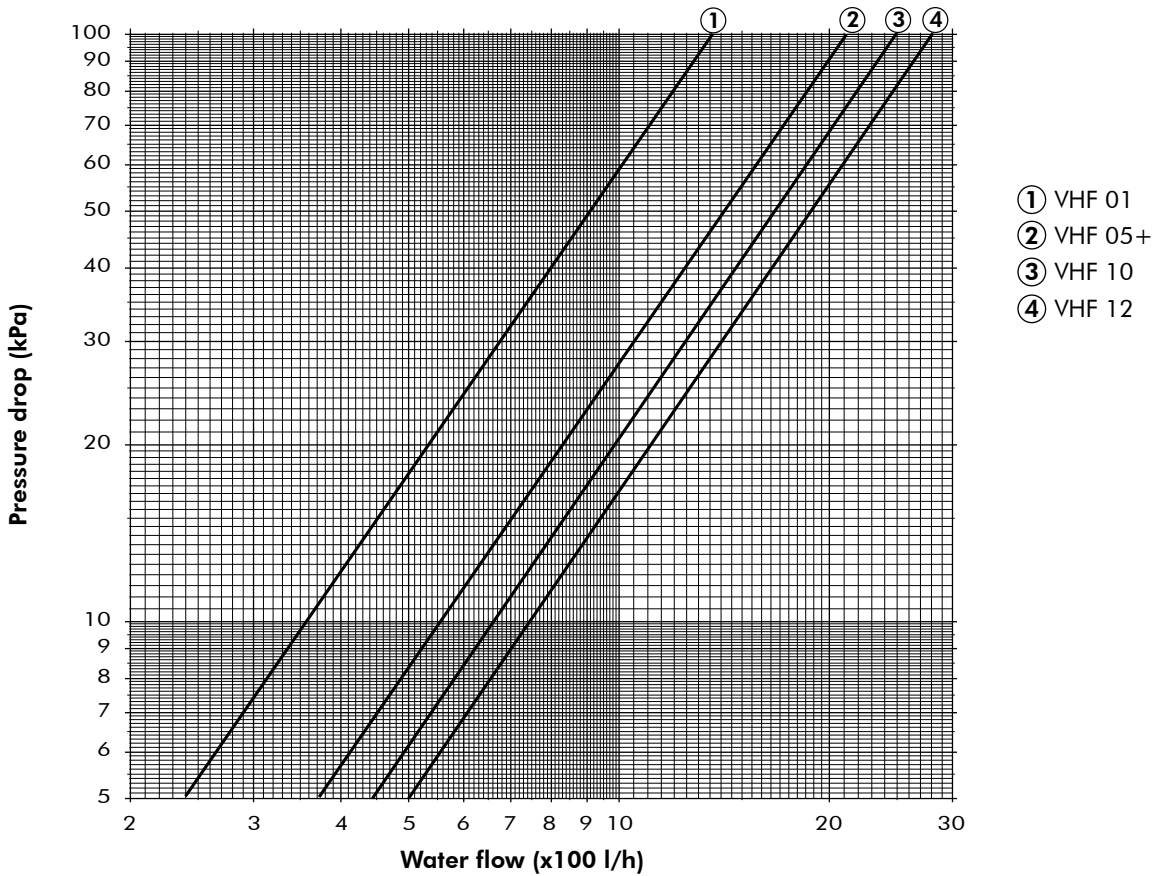

Water Pressure Drops - Heating Mode - 2-pipe system

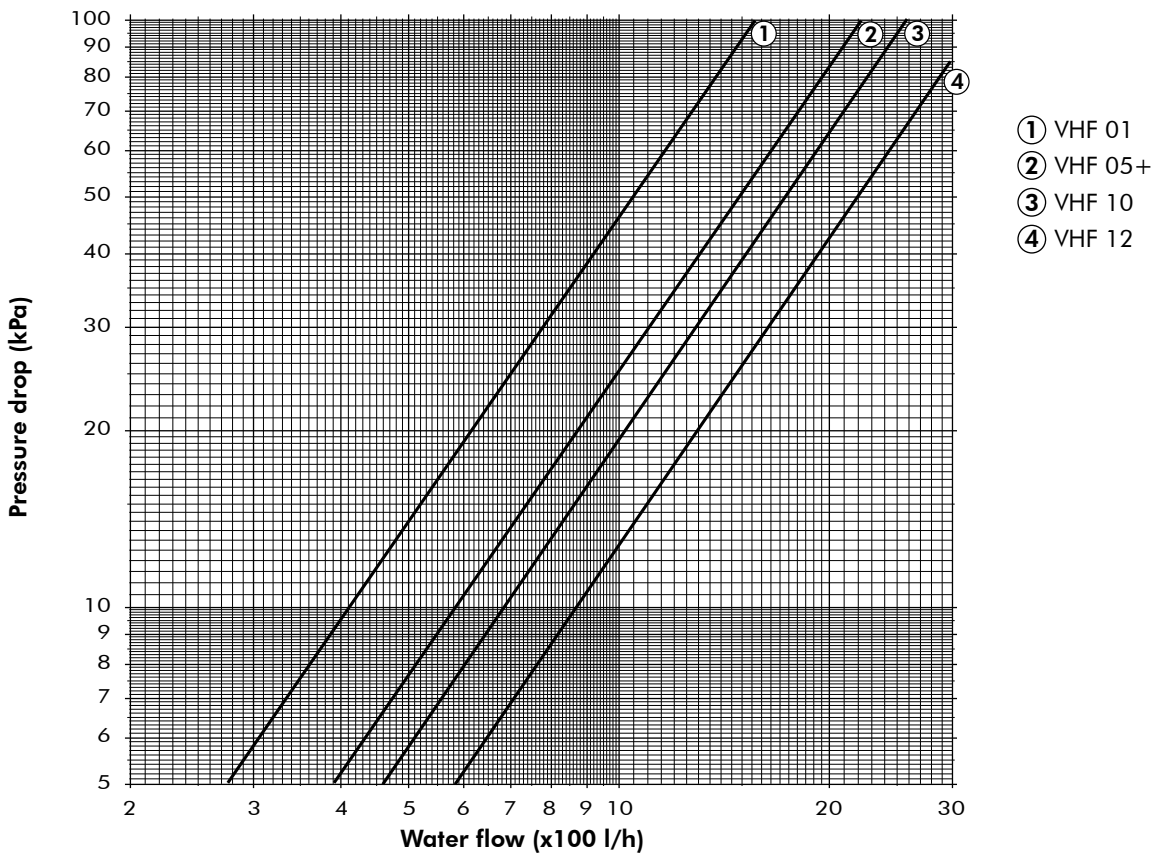

Water Pressure Drops - Cooling Mode - 4-pipe system

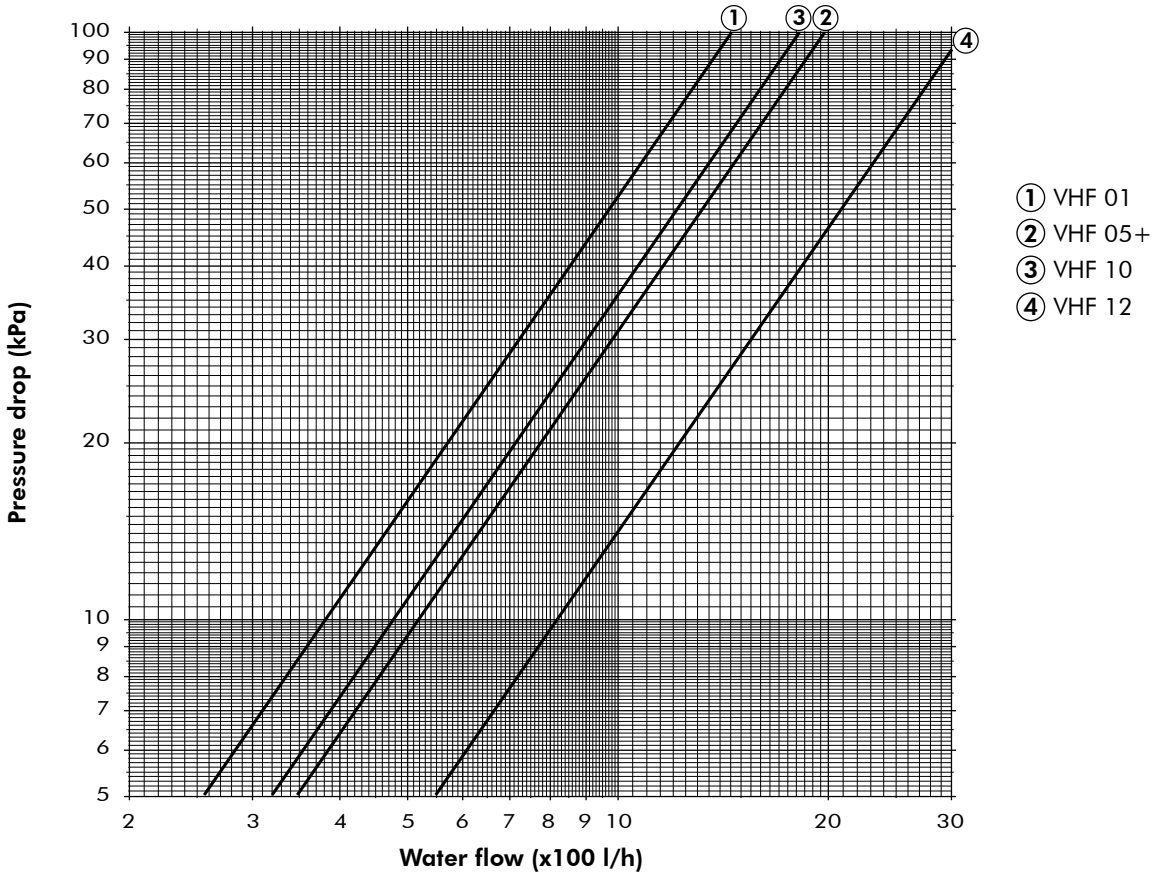

Water Pressure Drops - Heating Mode - 4-pipe system

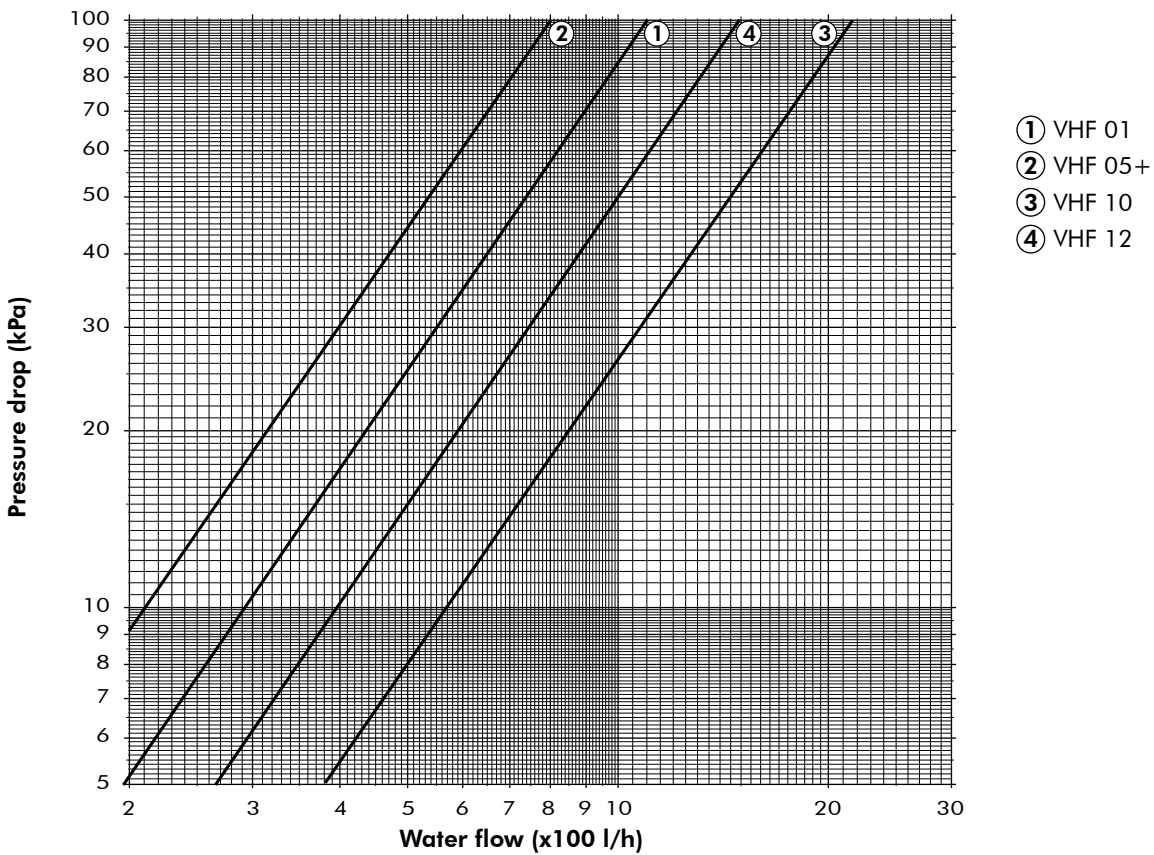

Dimensional Data - VHF 01

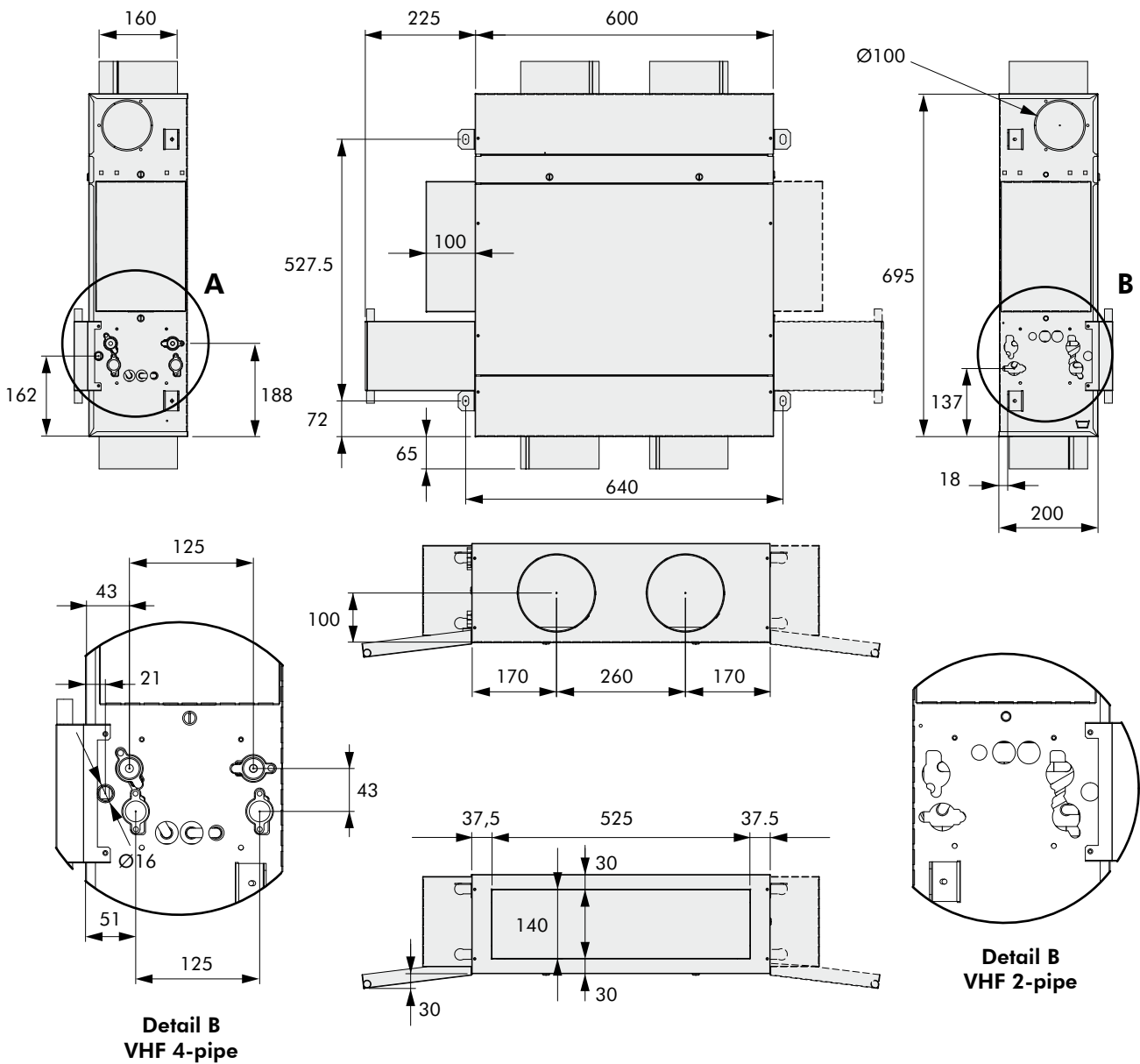
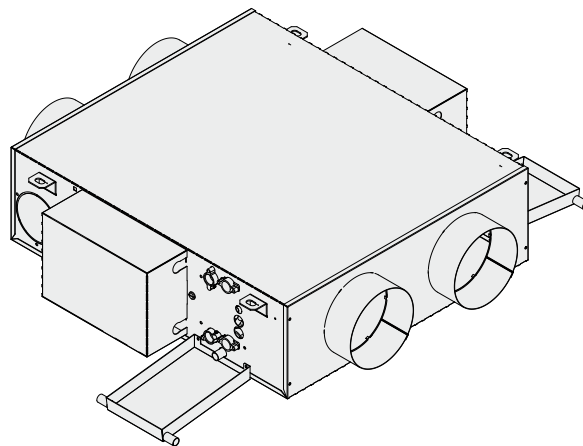
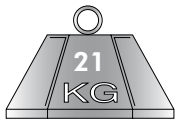

Nota : The weight is given for APSA version in operation without accessory, nor option.

Dimensional Data - VHF 05+

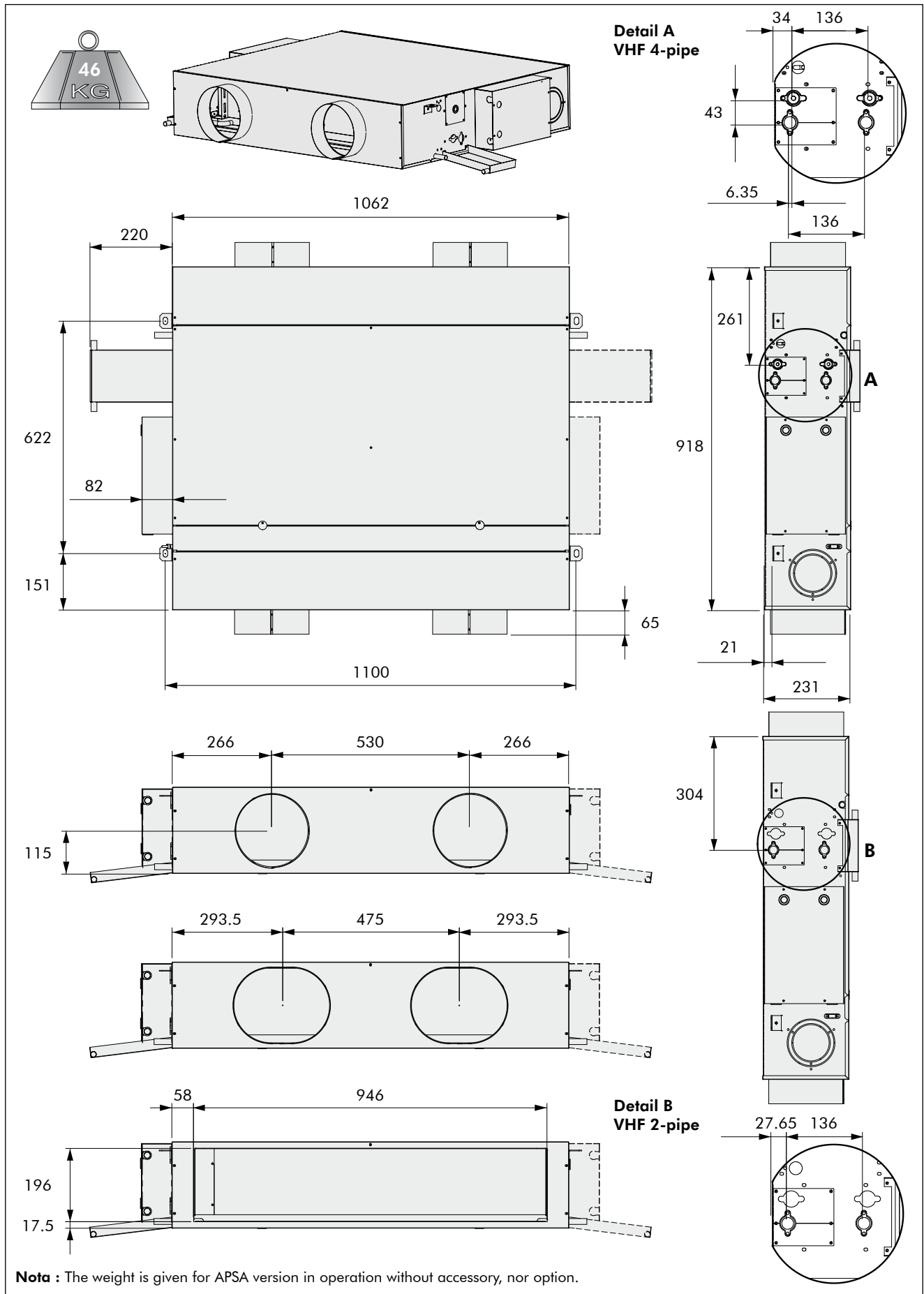

Dimensional Data - VHF 10

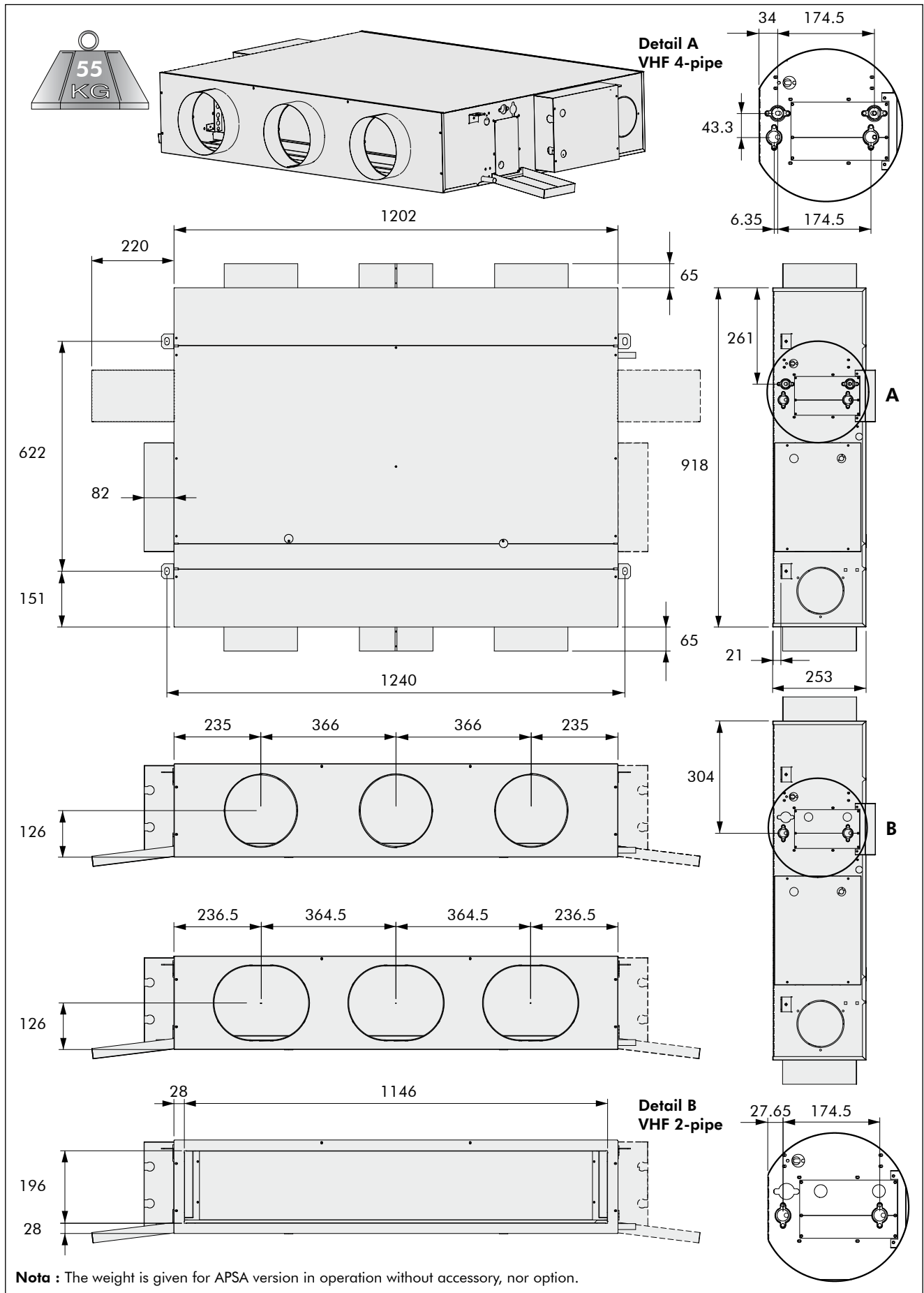

Dimensional Data - VHF 12

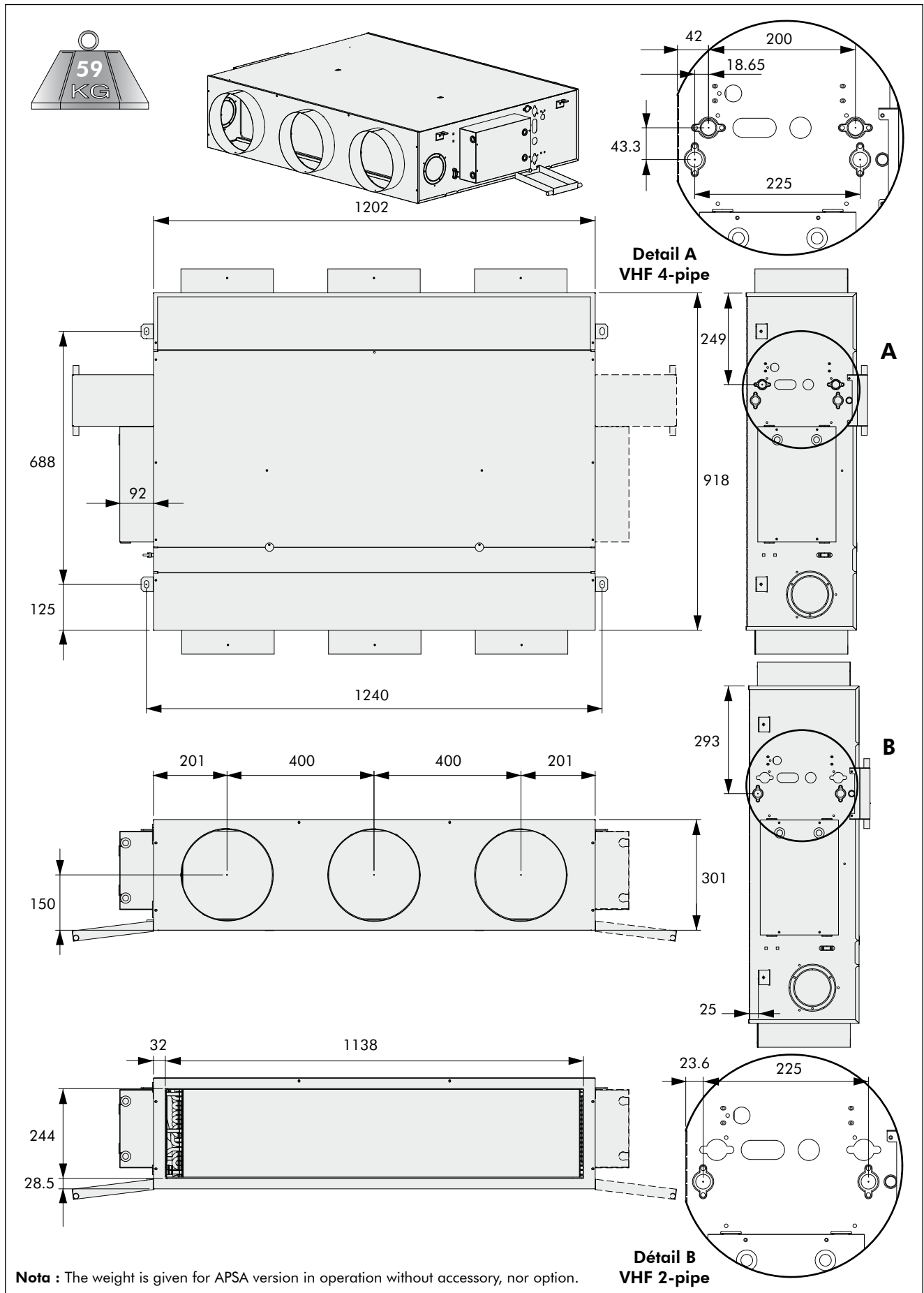

Definition of the Service Sides

The service side is determined by coil connection side when observer is looking at the unit from the discharge side.

LEFT-HAND service side

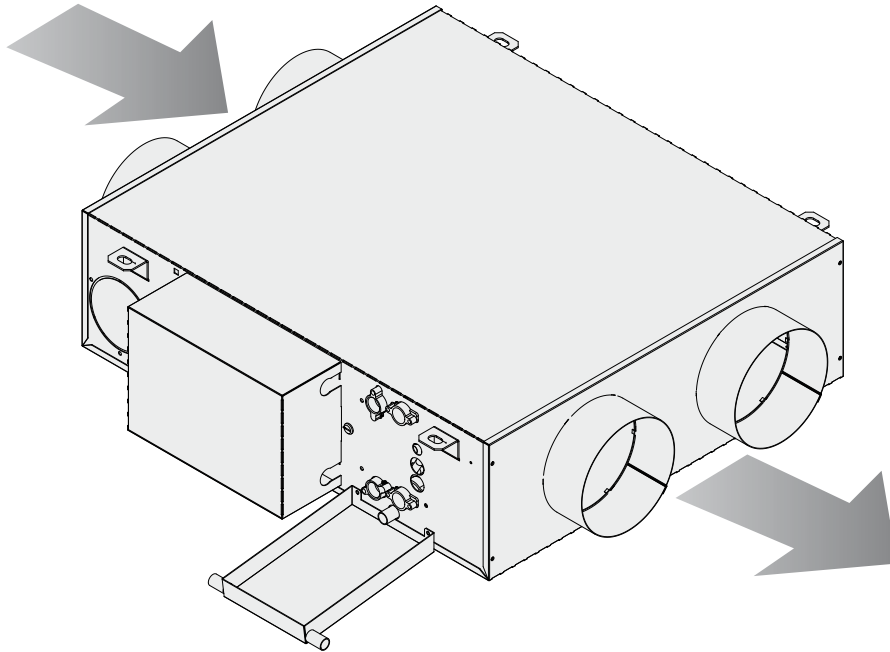

RIGHT-HAND service side

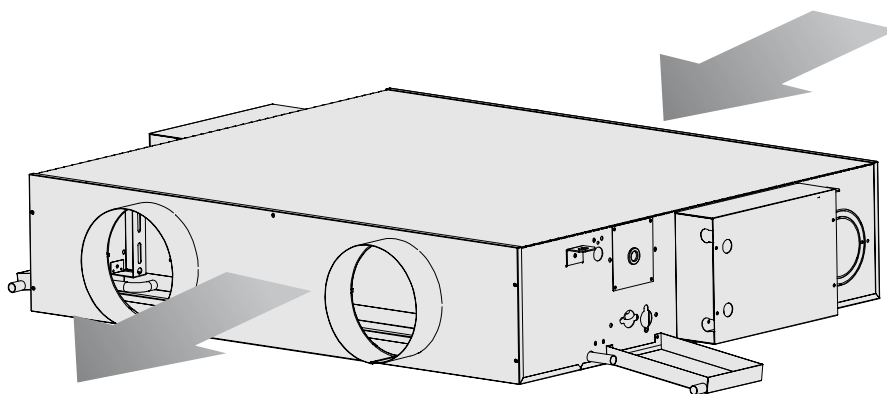

Wesper®

Airwell France S.A.S.

CAC Export Department

42 cours Jean-Jaurès

17800 Pons - France

Tel. : +33 (0)5 46 92 33 33 - Fax : +33 (0)5 46 91 26 44

www.wesper.com

Your distributor :

As part of our ongoing product improvement programme, our products are subject to change without prior notice. Non contractual photos.