

## ▶ Air Cooled Water Chillers

# AQCL 25 to 130 with centrifugal fans



25 to 125 kW



**Technical Catalogue**

**TM AQCL-N.3GB**

Date : December 2006

Supersedes : TM AQCL-N.2GB/09.05

# Aqu@Logic Centrifugal Fan Air Cooled Water Chillers

---

The new range of **AQCL** air cooled water chillers with **centrifugal fans** is composed of **11 models** covering a nominal cooling capacity range from 25 to 125 kW.

**AQCL** represents a new generation of innovative air cooled water chillers, integrating components using the very latest technological advances.

These components provide **AQCL** water chillers with considerable advantages in terms of compact design and improved efficiency and reliability.

All **AQCL** water chillers are equipped with **ILTC (Intelligent Liquid Technology Chiller)** control providing optimised control across the unit's entire operating range.

As standard equipment, each unit has two compressors, fitted in tandem, for adapting to partial system loads.

Pressure and temperature sensors provide data to the electronic control system for taking account of the prevailing operating parameters in order to optimise system performance.

This intelligent control system enables water temperature to be maintained within the required range, whilst only using a small volume of water (**2.5 l/kW**) and thus eliminating, for the majority of comfort air conditioning applications, the need for a buffer water tank.

## Features and Benefits

---

### A maximum of technology

The new generation of **AQCL** air cooled water chillers integrates high technology components :

- Scroll compressors.
- Brazed stainless steel plate heat exchangers.
- Microprocessor based **ILTC control**.
- HFC 407C refrigerant.

### Quick and easy installation at minimal cost

- Compact units taking up the strict minimum of ground surface area, for easy installation.
- "Plug and Play" design with an integrated hydraulic module for minimising installation costs.
- Perfect accessibility : easy access to all components, thanks to panels removable by screws, thus significantly reducing unit maintenance times.

### Increased performance

- Optimal efficiency, thanks to the use of Scroll compressors with

a high Coefficient Of Performance (COP), fitted in tandem on all models in the range.

### Built to last

- **ILTC control** automatically manages the balancing of the compressors' running times, thus enabling their service life to be extended.
- Sealed refrigerant circuit : all the refrigerant components and pipe work are brazed, thus eliminating any risks of leakage. Pressure transducers replace the HP and LP pressostats, along with their capillary tubes (principal source of leaks).

### Energy savings all year round

Thanks to **ILTC control** :

- Providing intelligent management of the compressors' running times.
- In the majority of cases, obviating the need for a buffer tank for comfort air conditioning applications (2.5 l/kW).
- Continuously monitoring and managing all the machine's operating parameters.

## General Specifications

---

### Cabinet and structure

- Made of galvanised steel panels coated with oven-baked epoxy paint. Colour : RAL 9001.
- For access to all components, the panels are removable by just removing the fixing screws.

### Compressors

- Hermetically sealed, high output Scroll type compressors with a high Coefficient Of Performance (COP).
- All models in the range equipped with compressors fitted in tandem for reducing both starting current draw and power

absorbed under partial load conditions.

- Excellent acoustic performance with extremely quiet operation and minimal vibration.
- Robust and reliable Scroll compressor technology :  
Few moving parts (only 3), high tolerance to liquid pressure shocks, low starting torque, protection against excessive discharge temperatures.
- Compressor motor cooled by intake gasses and equipped with automatic reset internal high temperature protection.
- All compressors are mounted on anti-vibration pads in order to minimise noise and vibration transmission.

# General Specifications (continued)

---

## Evaporator

---

- Direct expansion type, made of brazed stainless steel plates.
- The evaporator is surrounded by an electrical heating resistance and insulated with cellular polyurethane foam to provide anti-freeze protection.

## Air cooled condenser coil

---

Condenser coil consists of seamless copper tubes arranged in staggered row pattern.

The coil is mechanically expanded into aluminium fins with full fin collars.

Condensate drain pan, with two outlet pipes on both ends, is supplied underneath the condenser coil.

## Condenser fans and motor

---

Fans are of belt driven centrifugal type capable of providing external static pressures (standard and high pressures) to overcome the ductwork air resistance.

Variable pitch pulley is supplied as standard to allow air flow to be adjusted.

Electrical motor is of IP55 type and mounted on sliding plate allowing belt tension adjustment to be performed, by way of a single screw, without having to slacken the motor mounting.

Motor is protected by a circuit breaker. **Optional high static motor** can be supplied for high external static pressure applications.

## Fan discharge arrangement

---

The fan discharge of each unit can be configured in 3 different arrangements compared with horizontal return air :

- **Standard horizontal discharge (same side as return),**
- **Optional vertical discharge,**
- **Optional opposite horizontal discharge.**

At the discharge side, a duct collar is supplied as standard.

## Refrigerant circuit

---

The refrigerant circuit comprises all the required components such as filter-dryer, sight glass with moisture indicator and thermostatic expansion valve. It also comprises high and low pressure sensors, as well as sensors for inlet and outlet water temperatures and a discharge temperature sensor.

To facilitate maintenance operations, the low and high pressure sections of the refrigerant circuit are equipped with pressure tapping points.

All the refrigerant components and pipe work are brazed, thus eliminating any risks of leakage and ensuring total, long lasting circuit tightness.

Pressure transducers replace the HP (High Pressure) and LP (Low Pressure) pressostats, along with their capillary tubes (principal source of leaks).

The refrigerant circuit is optimised to operate with HFC 407C refrigerant.

## Electrical panel

---

Access to the electrical panel is possible after having taken off the panel, removable by just releasing the fixing screws.

The following equipment is mounted on the power circuit side of the electrical panel : a power supply connection terminal block - 400 V / 3 Ph / 50 Hz + Neutral, a main switch, a phase controller (allowing the presence and the order of the phases to be detected), contactors and magneto-thermal circuit breakers for the compressors, fans and hydraulic pump (if fitted). On the control circuit side of the panel, the ILTC control electronic circuit board with its 230 V single phase power supply is mounted.

## Integrated hydraulic module

---

An integrated hydraulic module is available for all **AQCL** units, offering savings in installation times and reducing installation costs. Each hydraulic module comprises the following components :

On models 25 to 35 : Automatic air bleed valve, differential pressostat, drain cock, expansion tank, safety valve, pressure gauge, hydraulic pump and water filter (supplied loose).

On models 40 to 130 : Automatic air bleed valve, water flow adjustment valve, water flow switch, drain cock, expansion tank, safety valve, pressure gauge, hydraulic pump and water filter (supplied fitted).

As standard, all pumps produce available pressure higher than 100 kPa.

## Other standard equipment

---

**Water flow switch or differential pressostat** : For **AQCL** units without an integrated hydraulic module, a factory-fitted differential pressostat (for models 25 to 35) and a factory-installed paddle type water flow switch (for models 40 to 130) are supplied as standard.

**Water filter** : Supplied loose on units without integrated hydraulic module.

## Accessories and options

---

→ **Anti-vibration pads** : Rubber anti-vibration pads, to be fitted on site by the installer.

→ **Anti-vibration mounts** : Visible spring anti-vibration mounts, for on site fitting by the installer.

→ **Compressor jacket** : Supplied fitted.

→ **Condenser coil protective coating** :

- aluminium fins with hydrophilic coating.
- aluminium fins with polyurethane coating.

→ **High static motor.**

→ **Remote control terminal** : Hard-wired control enabling the unit's Start / Stop functions to be controlled remotely.

→ **Low ambient kit (-7 °C)** : Factory-fitted option consists of frequency inverter acting on the motor in order to keep fan speed under control.

→ **Chiller sequencer** : Supplied loose, it allows a control up to 4 units.

→ **Water isolating valves** : Supplied loose.

→ **Water flow switch** : Factory-installed option for models 25 to 35.

→ **Double water pump.**

→ **Inlet air duct collar.**

# ILTC Control System

---

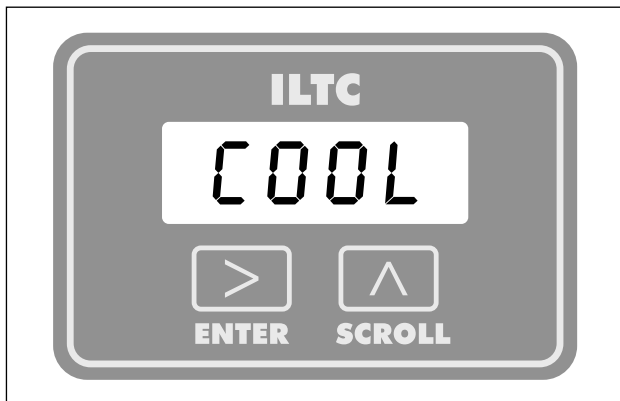

The ILTC control system is an intelligent digital control system designed especially for optimising the operation of AQCL units and maintaining conditions of maximum comfort.

Before each start-up, the ILTC control system runs through a complete machine checklist. It continuously monitors and manages all the machine's operating parameters and safety devices. It precisely manages the running of the compressors and fans in order to optimise energy consumption. It also controls the operation of the water circulation pump.

## User interface :

The ILTC control system has an easy-to-use user interface comprising a 4 character, 7 segment red colour LED display, 2 keys below the display for access to the different menus : the right key is reserved for scrolling up and down the menus, and the left key for selecting a parameter and displaying its value.

**Six main menus** are available for accessing all the machine's controls :

- Parameters.
- Temperature sensors and pressure transducers.
- Active safety alarms.
- Compressors' operating times.
- Safety alarms history (last 10 alarms).
- Machine operating status.

Using these 6 menus enables a machine status diagnosis to be performed as well as checking all the AQCL unit's parameter settings.

## ILTC control system description

---

- Intelligent control with return water temperature control and outlet water temperature measurement.
- The selection and operating time duration of each compressor is automatically managed by the ILTC control system, with the possibility of balancing the compressors' operating times. When they are operating, the compressors are monitored constantly to improve their operating cycle and to avoid any excessive cycling. Thus, these AQCL units can operate in complete safety with a low volume of water in the installation, enabling the buffer tank to be dispensed with in the majority of comfort air conditioning applications.
- The ILTC control system is intelligent, i.e. it continuously adapts to changes in the installation's thermal load by optimising running times with the selection of one or both compressors, in relation to actual demand.

- Water pump control with 2 possible operating modes: Continuous operation in ON / OFF mode or operating only in ON mode.
- As standard, the ILTC control system offers the possibility of selecting a "Night-time running mode" function.

When the "**Night-time Running**" mode is activated, four operating modes are available :

**1st mode** : Selected to change the set temperature for energy savings when the building is unoccupied.

**2nd mode** : Selected to enable the set temperature to be lowered.

**3rd mode** : Selected to change the set condensing pressure values.

**4th mode** : Selected for applying a combination of modes 1 and 3.

- In addition, as a standard feature, the ILTC control system offers the possibility of automatically compensating the set temperature value in relation to changes in the outdoor air temperature.

## Safety

---

The system measures changes in parameters (temperatures, pressures,...) and reacts to keep the compressor within its operating range.

If, despite everything, a parameter exceeds its limit, a warning message is generated and the machine is shut down.

The following faults cause the machine to shut down :

- Suction pressure too low.
- Discharge pressure too high.
- Outlet water temperature below authorised limits.
- Discharge temperature too high.
- Compressor(s), fan(s), water pump overload.
- Compressor direction of rotation reversed.
- Temperature sensors and pressure transducers fault.
- Evaporator anti-freeze protection.

The ILTC control system has **33 alarm codes** enabling the origin of breakdowns to be determined.

The following safety devices protect the units :

- Water flow switch or differential pressostat.
- Fan thermal relays.
- N° 1 and N° 2 compressor internal thermal protection.
- Hydraulic pump thermal relay.
- HP safety pressostat.

## Remote unit management

---

The system enables the following functions to be operated, by means of dry contacts :

- Remote ON / OFF switch.
- Remote Day / Night running mode switch.
- Loadshedding mode.
- Remote alarm reading.

# Refrigerant Flow Diagrams

## AQCL 20 to 80

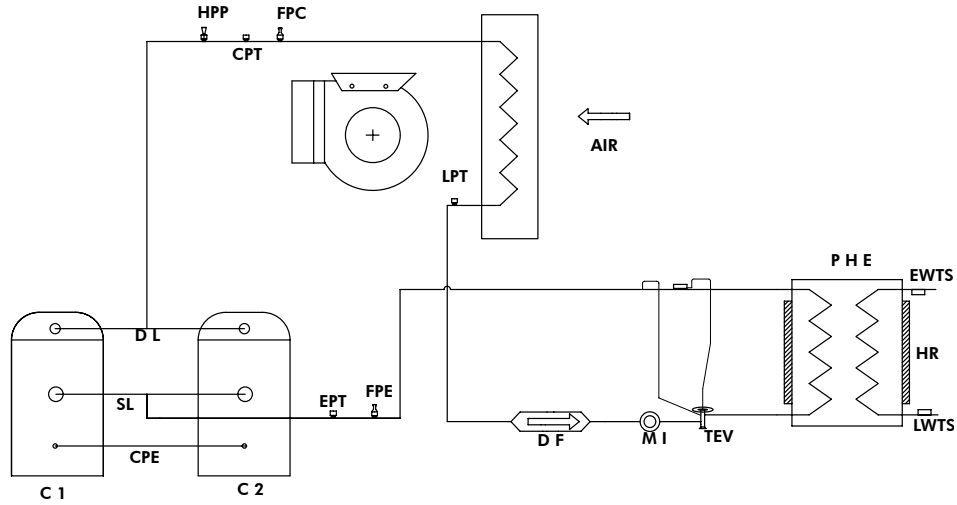

## AQCL 100 to 130

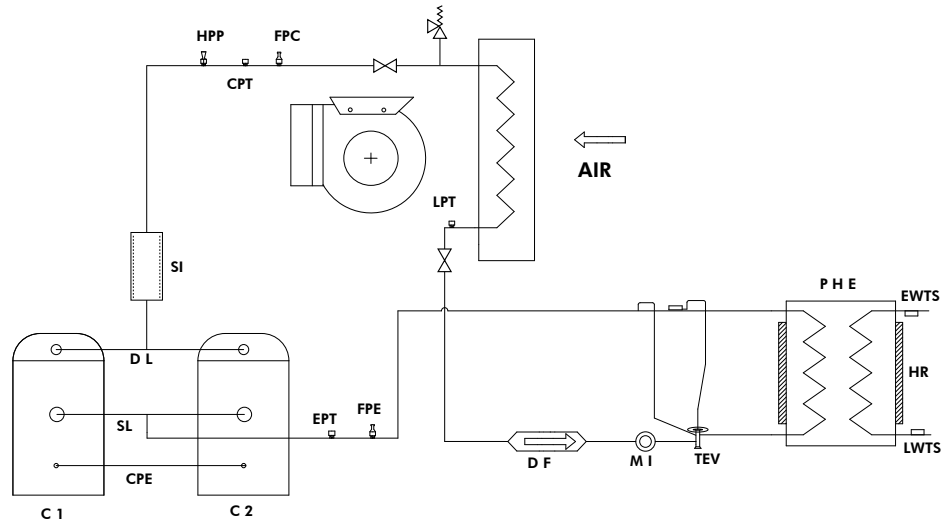

### COMPONENTS

<b>C1</b>	Compressor 1	<b>FPC</b>	Condensation pressure transducer	<b>CPE</b>	Oil level equalization
<b>C2</b>	Compressor 2	<b>FPE</b>	Evaporator pressure transducer	<b>PHE</b>	Plate heat exchanger
<b>CPT</b>	Condensing pressure tap	<b>HPP</b>	High pressure switch	<b>SI</b>	Silencer
<b>DF</b>	Filter drier	<b>HR</b>	Evaporator safety heater	<b>SL</b>	Suction line
<b>DL</b>	Discharge line	<b>LPT</b>	Liquid pressure tap	<b>TEV</b>	Thermostatic expansion valve
<b>EPT</b>	Evaporator pressure tap	<b>LWTS</b>	Leaving water temperature sensor		
<b>EWTS</b>	Entering water temperature sensor	<b>MI</b>	Moisture indicator		

## Protection devices

AQCL SIZES	25	30	35	40	50	60	70	80	100	120	130
Fan thermal protection						<b>YES</b>					
Compressors thermal protection								<b>YES</b>			
Ancillaries / Fan circuit breakers								<b>YES</b>			
Compressors circuit breakers		<b>YES</b>									
Water pressure differential pressostat		<b>YES</b>									
Water flow switch								<b>YES</b>			
HP pressostat						<b>YES</b>					
Evaporator anti-freeze protection						<b>YES</b>					
HP transducer						<b>YES</b>					
LP transducer						<b>YES</b>					

# Operating Limits

## Operating temperature ranges

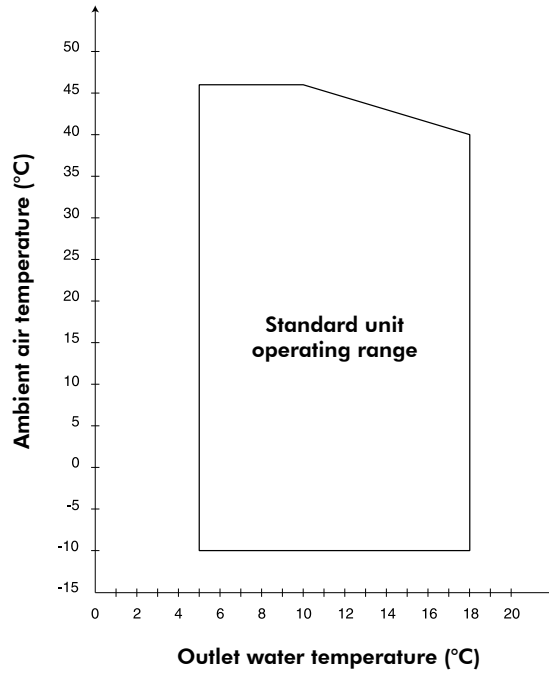

## Operating limit data (\*)

TEMPERATURE		MINI.	MAXI.
Inlet water at start-up	°C	10	30
Inlet water during running	°C	10	23
Outlet water during running (without glycol)	°C	5	18
Water temperature difference	K	3	7
Working pressure	bars	-	3
Air (standard unit)	°C	15	46
Air (unit with optional fan speed controller)	°C	-7	46

(\*) For chilled  $\Delta T = 5K$ .

## Correction Factors

### Altitude correction factors

Altitude (m)	Cooling capacity correction factors	Power consumption correction factors
0	1.000	1.000
600	0.987	1.010
1200	0.973	1.020
1800	0.958	1.029
2400	0.943	1.038

### Evaporator fouling factors

Fouling factors ( $m^2 \cdot ^\circ C / kW$ )	Cooling capacity correction factors	Power consumption correction factors
0.044	1.000	1.000
0.088	0.987	0.995
0.176	0.964	0.985
0.352	0.915	0.962

### Condenser fouling factors

Fouling factors ( $m^2 \cdot ^\circ C / kW$ )	Cooling capacity correction factors	Power consumption correction factors
0.044	1.000	1.000
0.088	0.987	1.023
0.176	0.955	1.068
0.352	0.910	1.135

# Hydraulic Circuit Diagrams

## Basic version

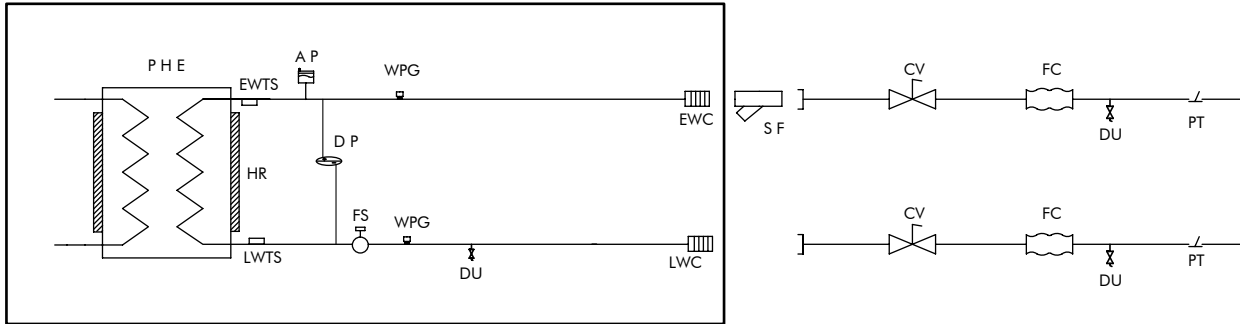

## Pack version

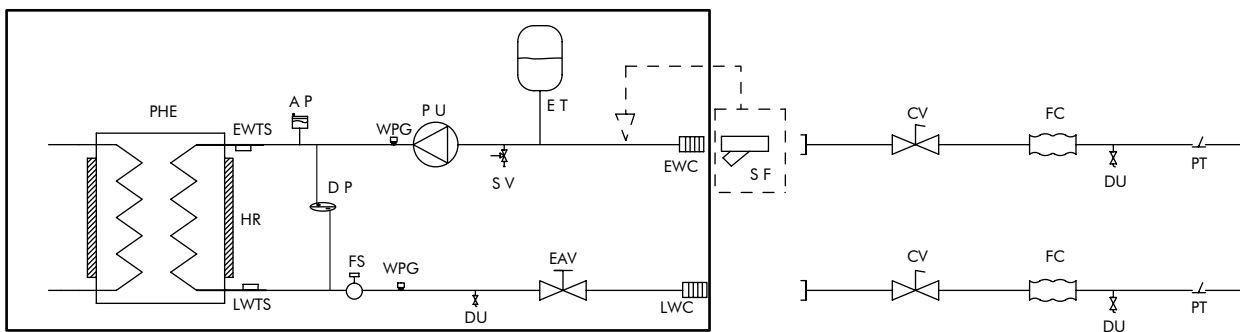

COMPONENTS			
<b>AP</b>	Automatic air purge valve	<b>HR</b>	Evaporator safety heater
<b>CV</b>	Isolating valve	<b>LWC</b>	Leaving water connection
<b>DP</b>	Differential pressure switch (only on models 25/30/35)	<b>LWTS</b>	Leaving water temperature sensor
<b>DU</b>	Drain off valve	<b>PHE</b>	Plate heat exchanger
<b>EAV</b>	Manual adjustment valve	<b>PT</b>	Temperature sensor
<b>ET</b>	Expansion tank	<b>PU</b>	Water pump
<b>EWC</b>	Entering water connection	<b>SF</b>	Screen filter (supplied loose for models 25/30/35)
<b>EWTS</b>	Entering water temperature sensor	<b>SV</b>	Safety valve
<b>FC</b>	Flexible joint	<b>WPG</b>	Water pressure tap
<b>FS</b>	Flow switch (only on models 40 to 130)		

## Hydraulic Circuit Water Volume

### Minimum volume for comfort air conditioning applications

SIZES	25	30	35	40	50	60	70	80	100	120	130
Volume * (litres)	65	75	85	105	120	145	170	200	251	300	325

(\*) Volumes calculated for Eurovent operating conditions (air : 35 °C, water 12/7 °C) with a 2.5 l/kW ratio. For other nominal operating conditions, recalculate the minimum volume by multiplying the corresponding cooling capacity by the 2.5l/kW ratio. If the minimum volume requirement can not be met, an additional buffer tank must be included in the installation.

### Maximum volume (\*) in litres for comfort air conditioning applications

SIZES	25 to 35	40 to 80	100 to 130
Water	300	600	1500
10% glycol solution	225	450	1200
15% glycol solution	215	425	1100
20% glycol solution	200	400	1000
25% glycol solution	185	375	930
30% glycol solution	175	350	860
35% glycol solution	150	300	800

(\*) Limit linked to the unit's expansion tank volume. In the case of an installation with a water volume greater than the values stated in the above table, an additional buffer tank must be included in the installation.

# Physical Data

AQCL SIZES		25	30	35	40	50	60	70	80	100	120	130
Power supply (V / Ph / Hz)		400/3+N/50										
Cooling capacity (1)	kW	24.9	28.8	33.7	39.6	46.2	56.3	67.5	76.5	99.1	113.7	124.8
Total power consumption with pump	kW	12.3	13.7	15.0	16.8	22.7	26.6	29.6	33.1	42.8	46.1	49.8
Total power consumption	kW	11.5	12.9	14.2	16.1	22.0	25.5	28.5	32.0	40.95	44.25	47.95
Refrigerant charge	kg	6.5	7.05	8.5	10	13.76	16	16.31	16.31	23	25	29
<b>COMPRESSORS</b>												
Type	Scroll											
Quantity		2	2	2	2	2	2	2	2	2	2	2
Capacity reduction stages		2	2	2	2	2	2	2	2	2	2	2
Minimum capacity	%	50	50	50	45	36	36	45	50	40	45	50
Safety pressostat	HP (fixed set point)											
	LP transducer											
	HP transducer											
<b>EVAPORATOR</b>												
Type	Braze stainless steel plates											
Maximum pressure refrigerant side	bar	30										
Maximum pressure water side	bar	10										
Safety	Pressure differential switch				Water flow switch							
Anti-freeze protection heating resistance		1	1	1	1	1	1	1	1	1	1	1
Water volume	litres	2.2	2.44	2.44	3.44	4.33	5.33	6.33	7.10	8.4	10.3	13.9
<b>CONDENSER</b>												
Type	3/8" copper tube - Smooth aluminium fins											
<b>FANS</b>												
Type	Centrifugal											
Number of fans		2	2	2	2	2	2	2	2	2	2	2
Nominal airflow* (standard motor)	m <sup>3</sup> /h	13500	14000	14000	15000	19500	20000	26000	27000	28500	29500	30000
External static pressure (standard motor)	Pa	130	130	130	130	130	130	230	200	165	120	100
Motor power (standard motor)	kW	3.0	3.0	3.0	4.0	5.5	5.5	7.5	7.5	7.5	7.5	7.5
External static pressure (high static option)	Pa	200	200	200	200	200	200	400	400	320	235	175
Motor power (high static option)	kW	4.0	4.0	4.0	5.5	7.5	7.5	11	11	11	11	11
<b>WATER CONNECTIONS</b>												
Type	Gas - Threaded											
Diameter	inches	1"1/2	1"1/2	1"1/2	2"	2"	2"	2"	2"	2"	2"	2"
Expansion tank	litres	5				12						
Filter		1" 1/2, supplied loose				2", supplied loose						
Safety valve calibration	bar	3	3	3	3	3	3	3	3	3	3	3
<b>WEIGHT</b>												
With pump	kg	387	405	415	575	630	660	865	920	1010	1080	1130
Without pump	kg	377	395	405	565	620	650	855	910	988	1058	1108
<b>DIMENSIONS</b>												
Length	mm	1750	1750	1750	2206	2206	2206	2464	2464	2464	2464	2464
Width	mm	890	890	890	890	890	890	1100	1100	1100	1100	1100
Height	mm	1505	1505	1505	1773	1773	1773	2313	2313	2313	2313	2313

(1) Values are based on chilled water inlet/outlet temperature of 12/7 °C and an outdoor temperature of 35 °C.



# Electrical Data

## Unit with standard fan motors

AQCL sizes	Fuse aM type - (A)	Full load current (max.) 400V - (A)	Starting current (max.) - (A)
25	32	25	80
30	32	27	82
35	40	31	122
40	50	44	140
50	50	47	186
60	63	53	232
70	80	68.8	230
80	80	71	233
100	125	102	322
120	175	110	330
130	175	120	340

## Unit with high static fan motors (optional)

AQCL sizes	Fuse aM type - (A)	Full load current (max.) 400V - (A)	Starting current (max.) - (A)
25	32	27	82
30	32	29	92
35	40	33	124
40	63	47	142
50	63	51	188
60	63	56	236
70	80	71.8	233
80	80	74	236
100	125	105	325
120	175	113	333
130	175	123	343

## Compressors

AQCL SIZES		25	30	35	40	50	60	70	80	100	120	130
Nominal power consumption	kW	4.3+4.3	5.0+5.0	6.1+6.1	7.9+6.4	11.2+6.4	13.8+7.6	13.8+11.2	13.8+13.8	12.3+20.2	16.5+20.2	20.2+20.2
Maximum power consumption	kW	6+6	7+7	8+8	10+8	15+8	18+10	18+15	18+18	17.3+29	23.8+29	29+29
Nominal current	A	8.1+8.1	8.8+8.8	11.2+11.2	14.3+12.2	19.3+12.2	23.1+14.3	23.1+19.3	23.1+23.1	22.3+35.1	28.6+35.1	35.1+35.1
Maximum current	A	10+10	11.4+11.4	13.3+13.3	18+14.6	25.6+14.6	27.8+18	27.8+25.6	27.8+27.8	29.2+47	38.5+47	47+47
Crankcase heater	W	70+70	70+70	70+70	70+70	70+70	70+70	70+70	70+70	75+130	130+130	130+130

## Standard fan motors

AQCL SIZES		25	30	35	40	50	60	70	80	100	120	130
Supply voltage (V / Ph / Hz)		400 / 3 / 50										
Nominal power input	kW	3.0	3.0	3.0	4.0	5.5	5.5	7.5	7.5	7.5	7.5	7.5
Nominal current input	A	6.3	6.3	6.3	8.1	11.0	11.0	14.7	14.7	14.7	14.7	14.7

## High static fan motors (optional)

AQCL SIZES		25	30	35	40	50	60	70	80	100	120	130
Supply voltage (V / Ph / Hz)		400 / 3 / 50										
Nominal power input	kW	4.0	4.0	4.0	5.5	7.5	7.5	11	11	11	11	11
Nominal current input	A	8.1	8.1	8.1	11.0	14.7	14.7	21	21	21	21	21

## Standard pumps

AQCL SIZES		25	30	35	40	50	60	70	80	100	120	130
Supply voltage (V / Ph / Hz)		400 / 3 / 50										
Nominal power input	kW	0.55	0.55	0.55	0.75	0.75	1.1	1.1	1.1	1.85	1.85	1.85
Nominal current input	A	1.7	1.7	1.7	2.1	2.1	3.1	3.1	3.1	4.6	4.6	4.6

## Evaporator heating resistance

AQCL SIZES		25	30	35	40	50	60	70	80	100	120	130
Supply voltage (V / Ph / Hz)		230 / 1 / 50										
Maximum power input	W	35	35	35	35	35	35	35	35	35	35	35

# Sound Data

## In-duct sound power levels at discharge side Units with standard fan motors and completely closed pulley

Sizes	Frequencies (Hz)								Lw global dB(A)
	63	125	250	500	1000	2000	4000	8000	
25	57.8	65.6	67.6	72.9	76.7	74.9	71.5	66.3	<b>81.0</b>
30	57.8	65.6	67.6	72.9	76.7	74.9	71.5	66.3	<b>81.0</b>
35	57.8	65.6	67.6	72.9	76.7	74.9	71.5	66.3	<b>81.0</b>
40	56.3	65.8	66.7	72.9	76.3	75.1	71.3	65.4	<b>80.8</b>
50	61.5	71.0	71.9	77.9	81.3	80.3	76.5	70.6	<b>86.1</b>
60	61.5	71.0	71.9	77.9	81.3	80.3	76.5	70.6	<b>86.1</b>
70	58.7	68.5	69.1	75.1	78.5	77.5	73.7	67.8	<b>83.3</b>
80	58.7	68.5	69.1	75.1	78.5	77.5	73.7	67.8	<b>83.3</b>
100	74.5	76.5	79.7	82.0	80.1	80.7	78.2	71.9	<b>87.8</b>
120	74.5	76.5	79.7	82.0	80.1	80.7	78.2	71.9	<b>87.8</b>
130	74.5	76.5	79.7	82.0	80.1	80.7	78.2	71.9	<b>87.8</b>

## In-duct sound power levels at discharge side Units with standard fan motors and pulley open 4 turns

Sizes	Frequencies (Hz)								Lw global dB(A)
	63	125	250	500	1000	2000	4000	8000	
25	51.8	62.1	63.0	69.0	72.5	71.5	67.5	61.2	<b>77.1</b>
30	51.9	62.1	63.0	69.0	72.6	71.5	67.6	61.5	<b>77.1</b>
35	51.9	62.1	63.0	69.0	72.6	71.5	67.6	61.5	<b>77.1</b>
40	52.8	62.3	63.2	69.2	72.6	71.6	67.8	61.9	<b>77.4</b>
50	58.0	67.5	68.4	74.4	77.8	76.8	73.0	67.1	<b>82.6</b>
60	58.0	67.5	68.4	74.4	77.8	76.8	73.0	67.1	<b>82.6</b>
70	54.8	64.3	65.2	71.2	74.6	73.6	69.8	63.9	<b>79.2</b>
80	54.8	64.3	65.2	71.2	74.6	73.6	69.8	63.9	<b>79.2</b>
100	71.4	73.4	76.6	78.9	77.0	77.6	75.1	68.8	<b>84.7</b>
120	71.4	73.4	76.6	78.9	77.0	77.6	75.1	68.8	<b>84.7</b>
130	71.4	73.4	76.6	78.9	77.0	77.6	75.1	68.8	<b>84.7</b>

## In-duct sound power levels at discharge side Units with high static fan motors and completely closed pulley

Sizes	Frequencies (Hz)								Lw global dB(A)
	63	125	250	500	1000	2000	4000	8000	
25	59.1	68.5	69.4	74.5	77.9	76.8	72.7	67.1	<b>82.5</b>
30	59.1	68.5	69.4	74.5	77.9	76.8	72.7	67.1	<b>82.5</b>
35	59.1	68.5	69.4	74.5	77.9	76.8	72.7	67.1	<b>82.5</b>
40	58.0	67.4	63.0	74.8	78.1	76.8	73.0	66.4	<b>82.5</b>
50	64.5	74.0	74.9	80.9	84.3	83.3	79.5	73.6	<b>89.1</b>
60	64.5	74.0	74.9	80.9	84.3	83.3	79.5	73.6	<b>89.1</b>
70	61.5	71.0	71.9	77.9	81.3	80.3	76.5	70.6	<b>86.1</b>
80	61.5	71.0	71.7	77.9	81.3	80.3	76.5	70.6	<b>86.1</b>
100	78.1	77.3	79.7	80.6	79.8	80.1	78.3	72.1	<b>87.4</b>
120	78.1	77.3	79.7	80.6	79.8	80.1	78.3	72.1	<b>87.4</b>
130	78.1	77.3	79.7	80.6	79.8	80.1	78.3	72.1	<b>87.4</b>

## In-duct sound power levels at discharge side Units with high static fan motors and pulley open 4 turns

Sizes	Frequencies (Hz)								Lw global dB(A)
	63	125	250	500	1000	2000	4000	8000	
25	57.5	65.6	67.6	72.9	76.7	74.9	71.5	66.3	<b>80.9</b>
30	57.5	65.6	67.6	72.9	76.7	74.9	71.5	66.3	<b>80.9</b>
35	57.5	65.6	67.6	72.9	76.7	74.9	71.5	66.3	<b>80.9</b>
40	56.3	65.8	66.7	72.9	76.3	75.1	71.3	65.4	<b>80.8</b>
50	61.9	71.4	72.3	78.3	81.7	80.7	76.9	71.0	<b>86.5</b>
60	61.9	71.4	72.3	78.3	81.7	80.7	76.9	71.0	<b>86.5</b>
70	59.1	65.8	66.8	72.9	76.3	75.1	71.3	65.4	<b>80.8</b>
80	59.7	65.5	66.8	72.7	76.3	75.1	71.3	65.4	<b>80.6</b>
100	75.0	74.2	76.6	77.5	76.7	77.0	75.2	69.0	<b>84.3</b>
120	75.0	74.2	76.6	77.5	76.7	77.0	75.2	69.0	<b>84.3</b>
130	75.0	74.2	76.6	77.5	76.7	77.0	75.2	69.0	<b>84.3</b>

# Performance Data

AQCL SIZES	OUTDOOR AIR TEMPERATURE (°C)														
	LWT (°C)	25		30		32		35		40		43		46	
		Cool. Cap. (kW)	Input Power (kW)	Cool. Cap. (kW)	Input Power (kW)	Cool. Cap. (kW)	Input Power (kW)	Cool. Cap. (kW)	Input Power (kW)	Cool. Cap. (kW)	Input Power (kW)	Cool. Cap. (kW)	Input Power (kW)	Cool. Cap. (kW)	Input Power (kW)
25	5	25.0	9.4	24.2	10.2	23.9	10.7	23.3	11.2	21.4	12.4	21.2	12.4	20.2	13.0
	6	25.7	9.5	25.0	10.4	24.6	10.7	24.1	11.4	22.2	12.5	22.0	12.5	20.8	13.1
	7	26.6	9.6	25.9	10.5	25.5	10.9	<b>24.9</b>	<b>11.5</b>	22.9	12.6	22.7	12.6	21.5	13.3
	8	27.4	9.6	26.7	10.6	26.3	11.0	25.8	11.6	23.7	12.6	23.5	12.6	22.3	13.4
	9	28.3	9.7	27.5	10.6	27.2	11.1	26.6	11.8	24.5	12.8	24.3	12.8	23.0	13.5
	10	29.2	9.9	28.4	10.7	28.0	11.1	27.4	11.8	25.3	12.9	25.1	12.9	23.7	13.6
30	5	29.0	10.4	28.1	11.5	27.8	12.0	27.2	12.7	25.1	13.8	23.8	14.7	22.5	15.5
	6	29.8	10.5	29.0	11.6	28.6	12.1	28.0	12.8	25.9	14.0	24.6	14.8	23.3	15.6
	7	30.7	10.7	29.8	11.7	29.5	12.2	<b>28.8</b>	<b>12.9</b>	26.7	14.2	25.3	14.9	24.1	15.7
	8	31.7	10.8	30.8	11.8	30.4	12.3	29.7	13.0	27.4	14.3	26.1	15.0	24.8	15.9
	9	32.5	10.9	31.7	12.0	31.2	12.4	30.6	13.1	28.3	14.3	26.9	15.1	25.6	16.1
	10	33.5	11.0	32.6	12.1	32.1	12.5	31.4	13.3	29.1	14.6	27.7	15.3	26.3	16.2
35	5	34.3	11.8	33.1	12.9	32.5	13.3	31.6	14.0	29.0	15.5	27.4	16.6	25.8	17.6
	6	35.4	12.0	34.1	13.1	33.5	13.4	32.7	14.1	30.0	15.7	28.4	16.7	26.7	17.7
	7	36.4	12.2	35.2	13.2	34.5	13.7	<b>33.7</b>	<b>14.2</b>	31.0	15.8	29.4	16.8	27.7	17.9
	8	37.5	12.3	36.2	13.3	35.7	13.8	34.7	14.3	32.0	16.0	30.4	16.9	28.7	17.9
	9	38.7	12.5	37.4	13.5	36.8	13.9	35.9	14.4	33.2	16.1	31.5	17.1	29.8	18.0
	10	39.8	12.6	38.5	13.7	38.0	14.0	37.1	14.6	34.4	16.1	32.7	17.1	31.1	18.0
40	5	39.5	13.2	38.5	14.5	38.0	15.0	37.2	15.9	34.5	17.4	32.8	18.3	31.1	19.4
	6	40.7	13.3	39.6	14.6	39.1	15.1	38.4	16.0	35.6	17.6	33.9	18.5	32.2	19.5
	7	42.1	13.3	40.9	14.7	40.4	15.3	<b>39.6</b>	<b>16.1</b>	36.7	17.7	34.9	18.6	33.2	19.6
	8	43.3	13.5	42.1	14.8	41.7	15.4	40.9	16.2	37.9	17.8	36.1	18.7	34.3	19.8
	9	44.6	13.6	43.4	14.9	42.9	15.5	42.1	16.3	39.1	17.9	37.1	18.9	35.3	19.9
	10	45.9	13.7	44.8	15.0	44.2	15.6	43.4	16.5	40.2	18.0	38.3	19.1	36.5	20.0
50	5	46.5	18.1	45.1	19.8	44.6	20.5	43.6	21.6	40.1	23.5	38.1	24.8	36.1	26.0
	6	47.9	18.2	46.4	20.0	45.8	20.7	44.8	21.8	41.4	23.8	39.3	25.0	37.2	26.2
	7	49.2	18.5	47.7	20.2	47.2	20.9	<b>46.2</b>	<b>22.0</b>	42.6	24.0	40.5	25.2	38.3	26.5
	8	50.6	18.7	49.2	20.3	48.5	21.1	47.5	22.2	43.8	24.3	41.7	25.5	39.5	26.9
	9	51.9	18.8	50.5	20.6	49.8	21.3	48.8	22.4	45.1	24.5	42.8	25.8	40.7	27.1
	10	53.3	19.0	51.8	20.8	51.2	21.6	50.2	22.7	46.3	24.8	44.1	26.1	41.8	27.4
60	5	56.3	21.0	54.8	22.9	54.1	23.7	53.1	25.0	49.0	27.3	46.6	28.7	44.2	30.1
	6	58.0	21.1	56.4	23.2	55.7	24.0	54.6	25.2	50.5	27.6	48.0	29.0	45.6	30.4
	7	59.8	21.4	58.1	23.4	57.5	24.2	<b>56.3</b>	<b>25.5</b>	52.1	27.8	49.5	29.2	47.0	30.8
	8	61.5	21.7	59.8	23.6	59.1	24.5	58.1	25.8	53.6	28.2	51.0	29.6	48.4	31.1
	9	63.3	21.8	61.6	23.8	60.8	24.7	59.7	26.0	55.3	28.4	52.5	29.9	49.8	31.4
	10	65.1	22.0	63.4	24.1	62.7	25.0	61.5	26.3	56.8	28.7	54.0	30.2	51.2	31.8
70	5	67.5	23.5	65.7	25.6	64.9	26.5	63.6	27.9	58.8	30.5	55.9	32.1	53.0	33.7
	6	69.5	23.6	67.6	25.9	66.8	26.8	65.5	28.2	60.6	30.8	57.6	32.4	54.7	33.9
	7	71.6	23.9	69.7	26.2	68.9	27.1	<b>67.5</b>	<b>28.5</b>	62.4	31.1	59.4	32.7	56.3	34.4
	8	73.8	24.2	71.7	26.4	70.9	27.4	69.6	28.8	64.3	31.5	61.1	33.1	58.0	34.8
	9	75.9	24.3	73.9	26.6	72.9	27.6	71.6	29.1	66.2	31.8	62.9	33.4	59.7	35.1
	10	78.1	24.6	76.0	26.9	75.1	27.9	73.7	29.4	68.1	32.1	64.8	33.8	61.4	35.5
80	5	77.0	26.4	74.7	28.8	73.9	29.7	72.3	31.4	66.5	34.3	63.2	36.0	59.9	37.8
	6	79.3	26.5	76.9	29.1	75.9	30.1	74.4	31.7	68.6	34.6	65.2	36.3	61.7	38.1
	7	81.4	26.9	79.1	29.4	78.1	30.4	<b>76.6</b>	<b>32.0</b>	70.6	34.9	67.1	36.7	63.6	38.6
	8	83.7	27.2	81.4	29.6	80.3	30.7	78.7	32.3	72.7	35.4	69.1	37.1	65.4	39.1
	9	86.0	27.3	83.6	29.9	82.4	31.0	80.9	32.6	74.7	35.7	70.9	37.5	67.4	39.4
	10	88.3	27.7	85.8	30.2	84.8	31.4	83.2	33.0	76.7	36.0	73.1	37.9	69.3	39.9
100	5	99.1	33.7	96.4	36.8	95.2	38.1	93.4	40.1	86.2	43.8	82.0	46.1	77.8	48.4
	6	102.0	34.4	99.2	37.2	98.1	38.5	96.1	40.5	88.9	44.2	84.5	46.5	80.3	48.8
	7	105.1	34.8	102.3	37.7	101.1	38.9	<b>99.1</b>	<b>41.0</b>	91.6	44.7	87.2	46.9	82.6	49.4
	8	108.2	35.0	105.3	37.9	104.0	39.3	102.2	41.4	94.3	45.3	89.7	47.5	85.1	50.0
	9	111.4	35.4	108.5	38.3	107.0	39.7	105.1	41.8	97.2	45.7	92.4	47.9	87.6	50.4
	10	114.6	33.7	111.5	38.7	110.3	40.1	108.2	42.2	99.9	46.1	95.0	48.6	90.1	51.0
120	5	113.8	36.4	110.6	39.8	109.3	41.1	107.2	43.3	99.0	47.3	94.1	49.8	89.3	52.2
	6	117.1	37.1	113.9	40.2	112.6	41.5	110.3	43.8	102.1	47.8	97.0	50.2	92.2	52.6
	7	120.7	37.5	117.4	40.6	116.1	42.0	<b>113.7</b>	<b>44.2</b>	105.2	48.2	100.1	50.6	94.8	53.3
	8	124.2	37.8	120.8	40.9	119.4	42.4	117.3	44.6	108.3	48.9	102.9	51.3	97.7	54.0
	9	127.8	38.2	124.5	41.3	122.9	42.9	120.6	45.1	111.6	49.3	106.0	51.8	100.5	54.4
	10	131.6	36.4	127.9	41.8	126.6	43.3	124.2	45.5	114.7	49.8	109.1	52.4	103.4	55.1
130	5	124.9	39.5	121.4	43.1	119.9	44.6	117.7	47.0	108.6	51.3	103.3	54.0	98.1	56.6
	6	128.6	40.2	125.0	43.6	123.5	45.1	121.1	47.5	112.0	51.8	106.5	54.5	101.2	57.1
	7	132.5	40.7	128.8	44.1	127.4	45.5	<b>124.8</b>	<b>48.0</b>	115.5	52.3	109.8	54.9	104.1	57.8
	8	136.4	41.0	132.6	44.3	131.0	46.0	128.7	48.4	118.9	53.0	113.0	55.7	107.2	58.6
	9	140.3	41.4	136.6	44.8	134.9	46.5	132.4	48.9	122.5	53.5	116.4	56.1	110.4	59.0
	10	144.4	0.0	140.4	45.3	138.9	47.0	136.3	49.4	125.9	54.0	119.7	56.9	113.5	59.8

LWT : leaving water temperature.

Power input values are given for compressors and fan motor.

# Hydraulic Pump External Static Pressure

## Models 25 & 30

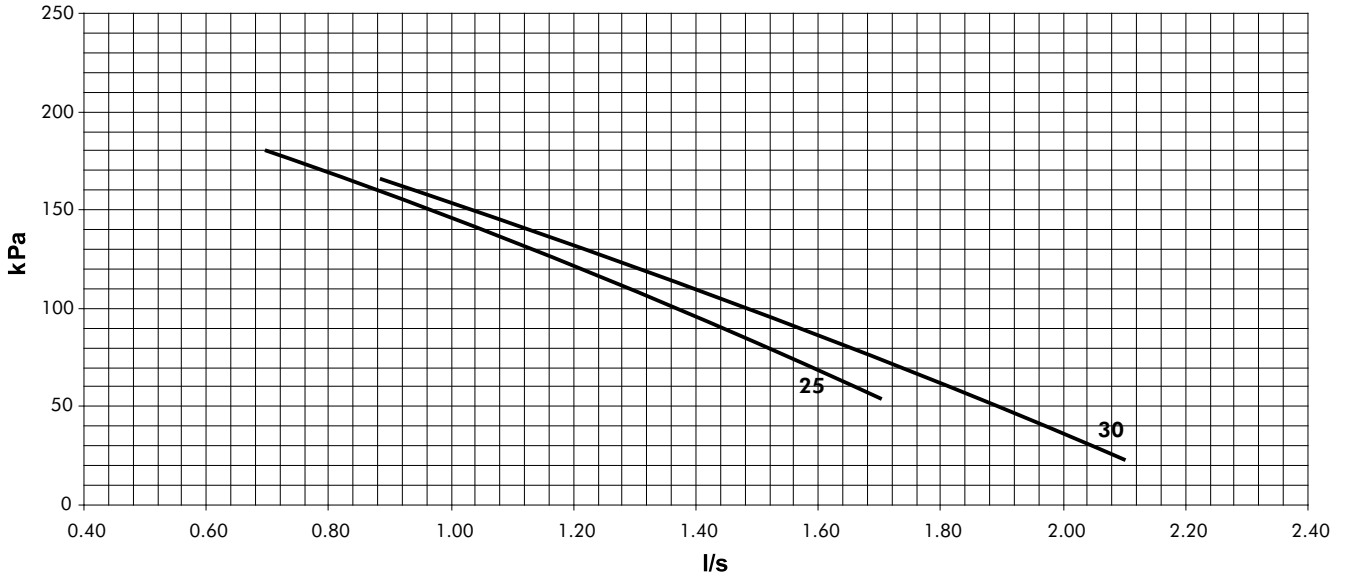

WATER FLOW (l/s)	MODEL 25	MODEL 30
Nominal (1)	1.04	1.29
Minimum (2)	0.7	0.86
Maximum (3)	1.73	2.15

(1) Eurovent conditions, Water : 12/7 °C, Air : 35 °C.

(2) With water  $\Delta T$  : 7.5 K at nominal capacity.

(3) With water  $\Delta T$  : 3 K at nominal capacity.

## Models 35, 40, 50, 60, 70 & 80

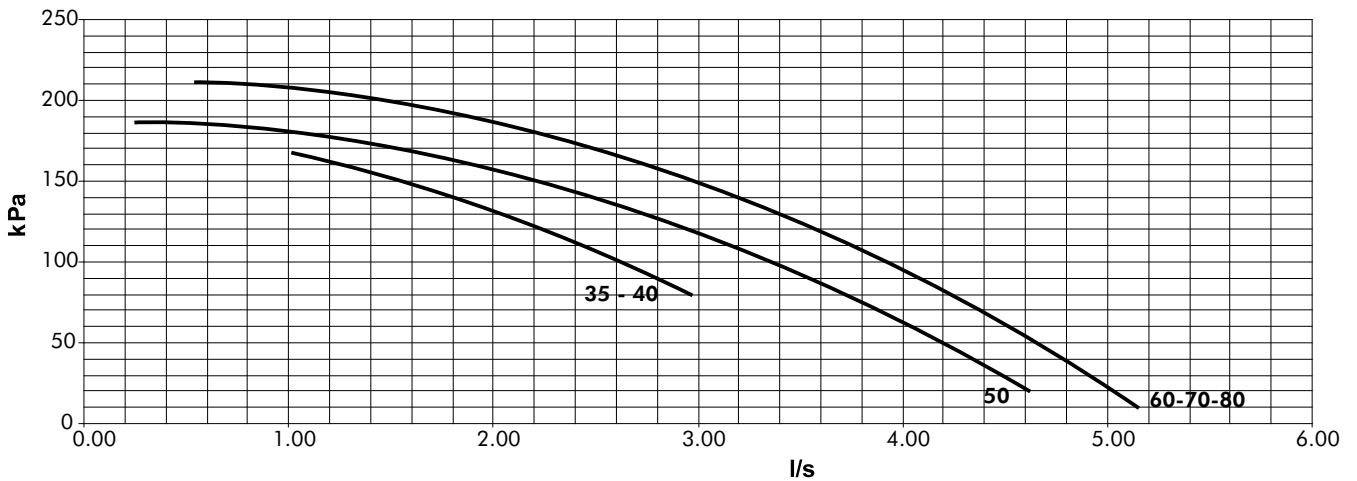

WATER FLOW (l/s)	MODEL 35	MODEL 40	MODEL 50	MODEL 60	MODEL 70	MODEL 80
Nominal (1)	1.60	1.75	2.16	2.75	3.08	3.2
Minimum (2)	1.07	1.16	1.45	1.80	2.1	2.3
Maximum (3)	2.68	2.92	3.58	4.56	5.09	5.3

(1) Eurovent conditions, Water : 12/7 °C, Air : 35 °C.

(2) With water  $\Delta T$  : 7.5 K at nominal capacity.

(3) With water  $\Delta T$  : 3 K at nominal capacity.

# Hydraulic Pump External Static Pressure (continued)

## Models 100, 1200 & 130

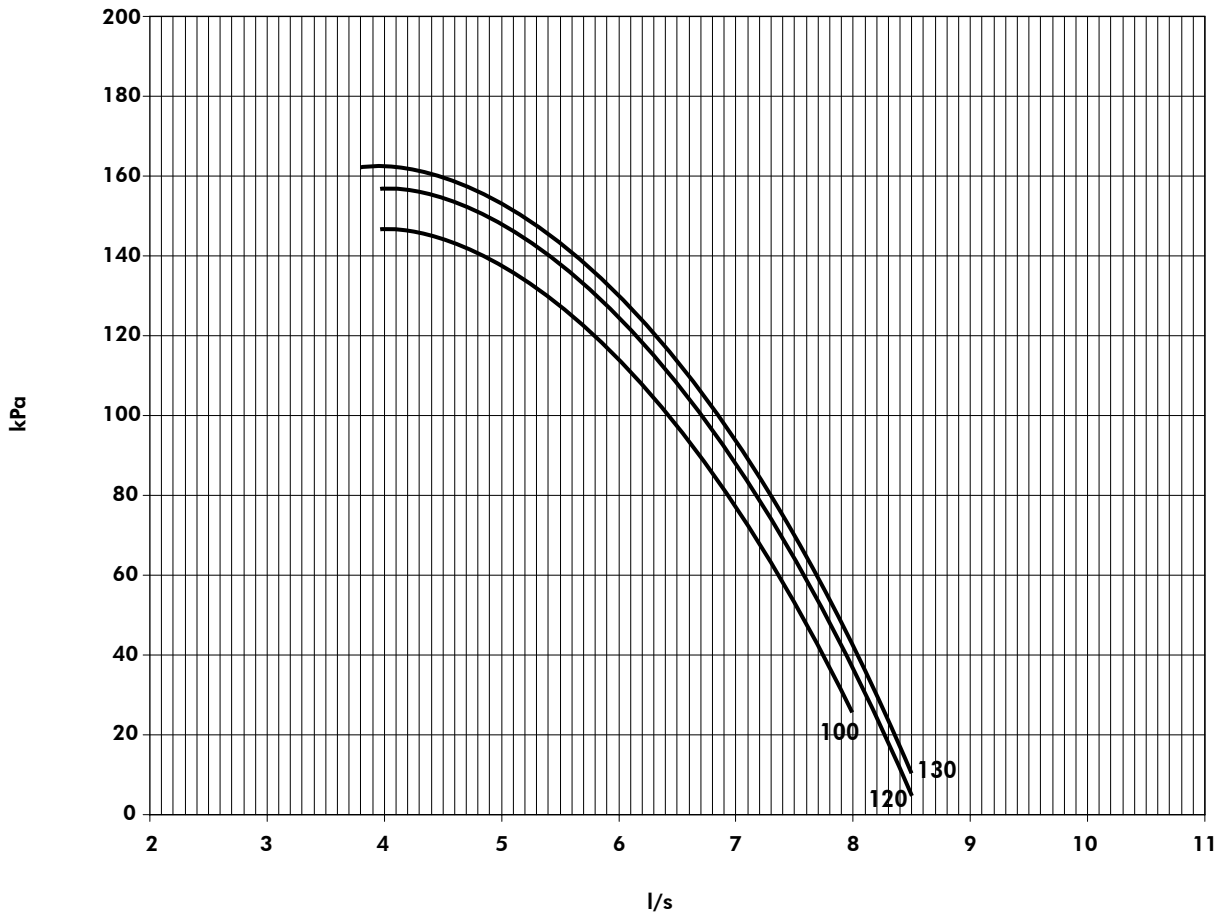

WATER FLOW (l/s)	MODEL 100	MODEL 120	MODEL 130
Nominal <b>(1)</b>	4.74	5.44	5.97
Minimum <b>(2)</b>	3.16	3.63	3.98
Maximum <b>(3)</b>	7.90	9.07	9.95

**(1)** Eurovent conditions, Water : 12/7 °C, Air : 35 °C.

**(2)** With water  $\Delta T$  : 7.5 K at nominal capacity.

**(3)** With water  $\Delta T$  : 3 K at nominal capacity.

# Heat Exchanger Water Pressure Drop

## Models 25, 30 & 35

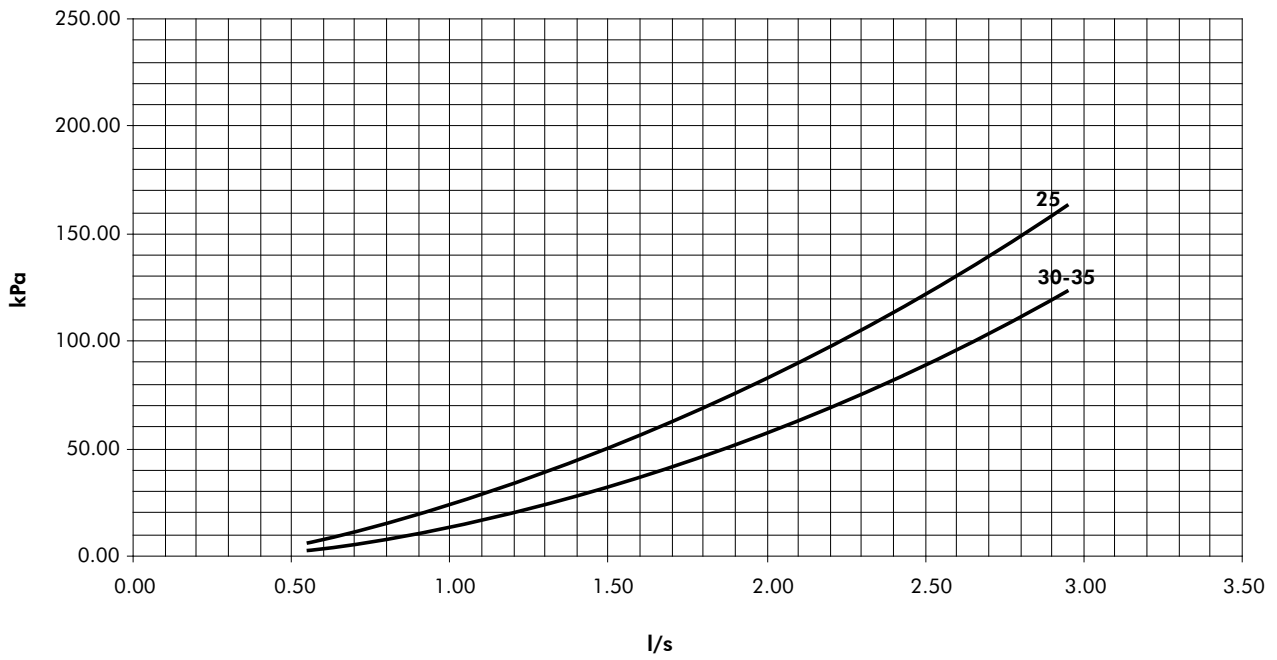

## Models 40, 50, 60, 70 & 80

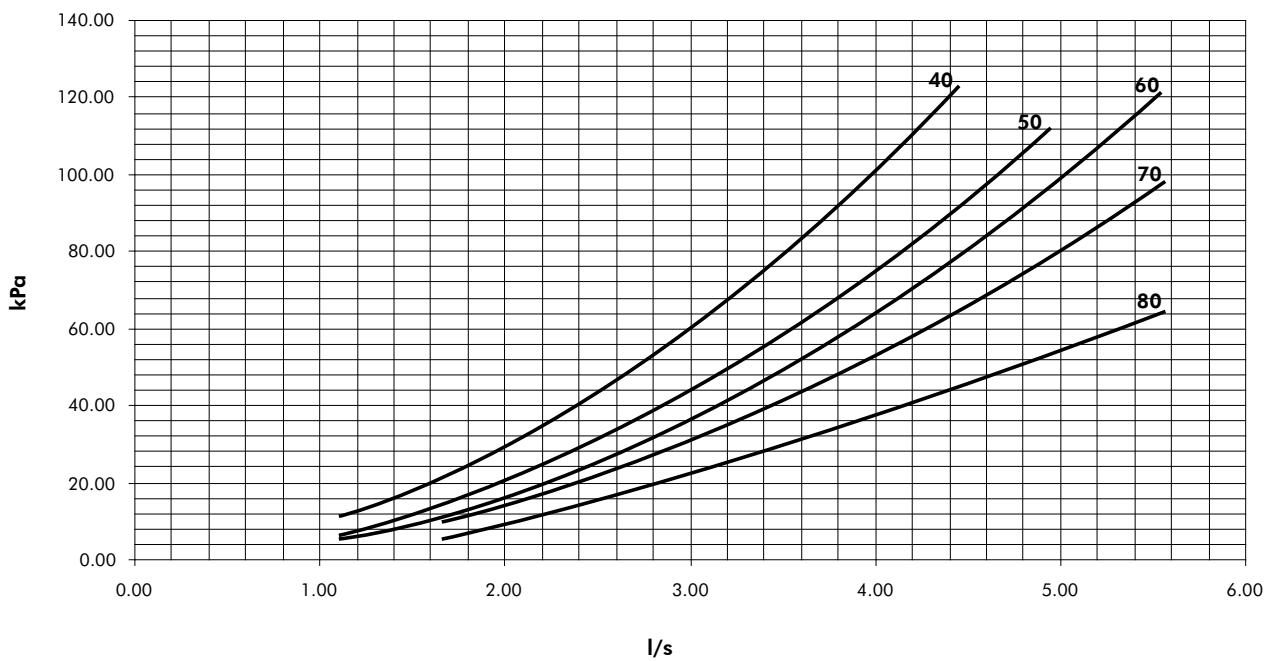

# Heat Exchanger Water Pressure Drop (continued)

---

## Models 100, 120 & 130

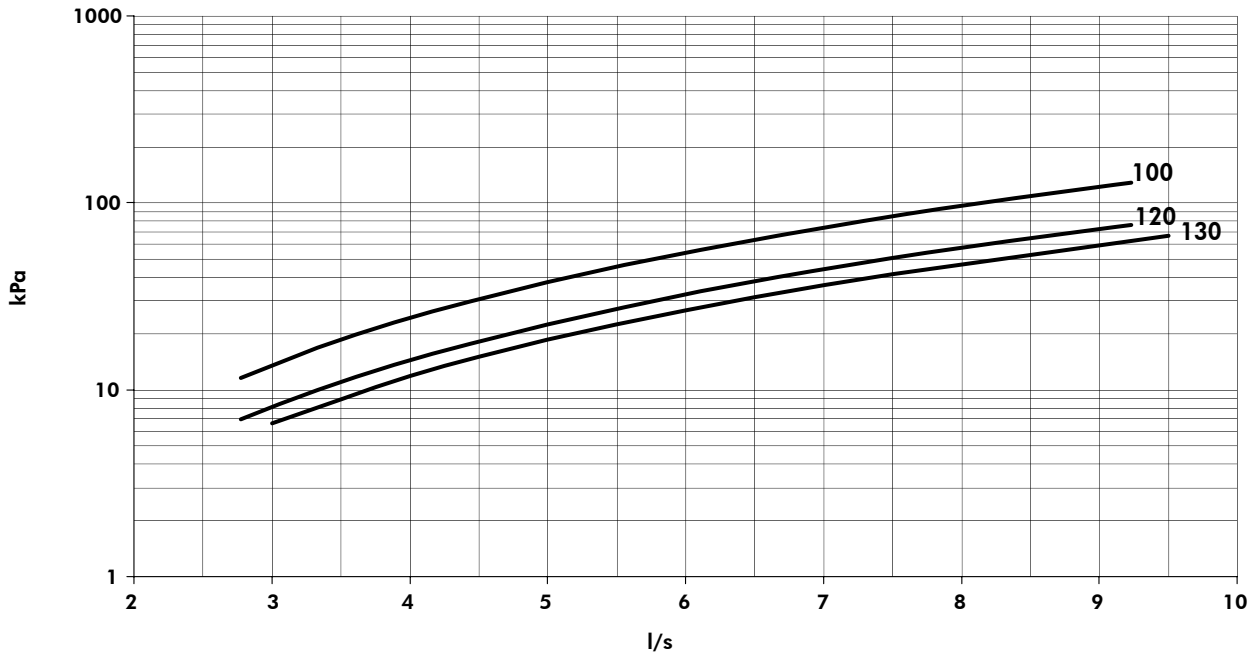

# Dimensions (mm)

## Unit overall dimensions

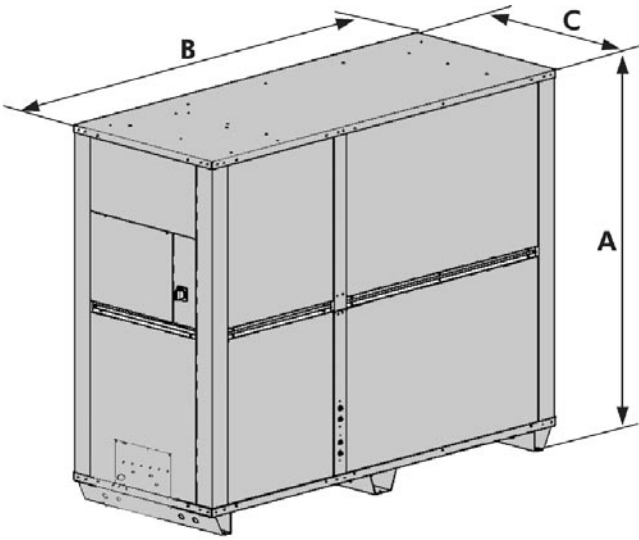

AQCL sizes	A	B	C
25	1505	1750	890
30	1505	1750	890
35	1505	1750	890
40	1773	2206	890
50	1773	2206	890
60	1773	2206	890
70	2313	2464	1100
80	2313	2464	1100
100	2313	2464	1100
120	2313	2464	1100
130	2313	2464	1100

## Standard blowing

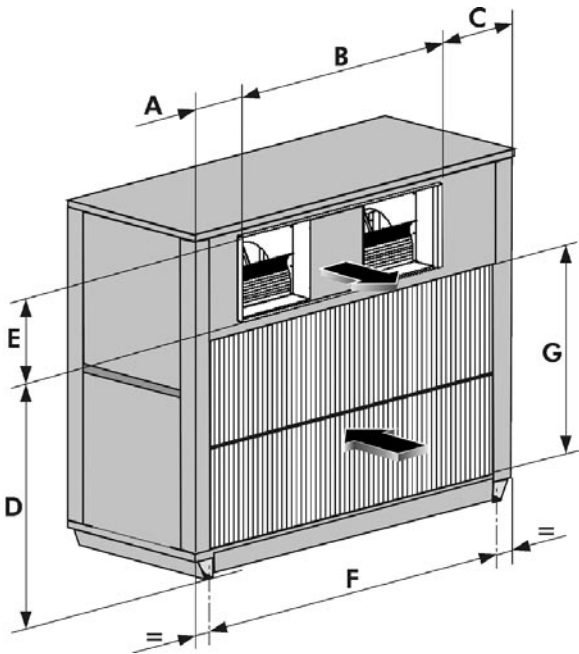

AQCL sizes	A	B	C	D	E	F	G
25	150	1350	250	1115	348	1500	950
30	150	1350	250	1115	348	1500	950
35	150	1350	250	1115	348	1500	950
40	285	1400	530	1275	450	2110	1085
50	285	1400	530	1275	450	2110	1085
60	285	1400	530	1275	450	2110	1085
70	314	1600	544	1745	500	2240	1500
80	314	1600	544	1745	500	2240	1500
100	314	1600	544	1745	500	2240	1500
120	314	1600	544	1745	500	2240	1500
130	314	1600	544	1745	500	2240	1500



# Dimensions (mm)

## Opposite blowing

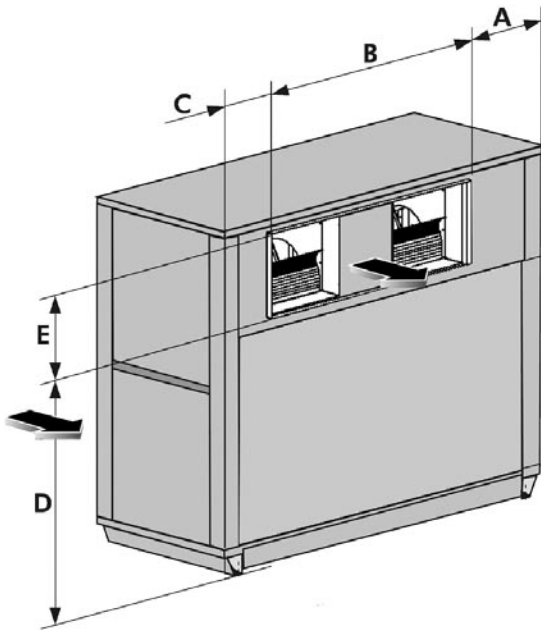

AQCL sizes	A	B	C	D	E
25	250	1350	150	1115	348
30	250	1350	150	1115	348
35	250	1350	150	1115	348
40	530	1400	285	1275	450
50	530	1400	285	1275	450
60	530	1400	285	1275	450
70	544	1600	314	1745	500
80	544	1600	314	1745	500
100	544	1600	314	1745	500
120	544	1600	314	1745	500
130	544	1600	314	1745	500

## Vertical blowing

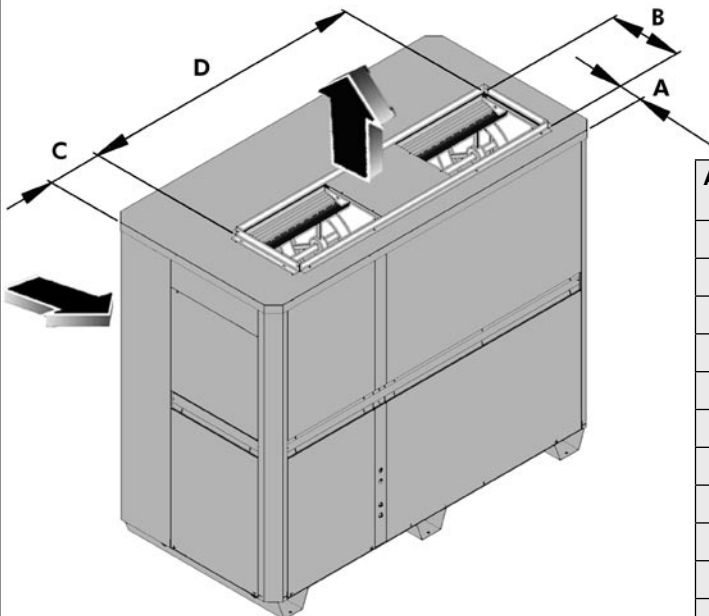

AQCL sizes	A	B	C	D
25	63	443	188	1448
30	63	443	188	1448
35	63	443	188	1448
40	215	445	595	1490
50	215	445	595	1490
60	215	445	595	1490
70	150	500	544	1600
80	150	500	544	1600
100	150	500	544	1600
120	150	500	544	1600
130	150	500	544	1600

# Water Connection Side and Electrical Access

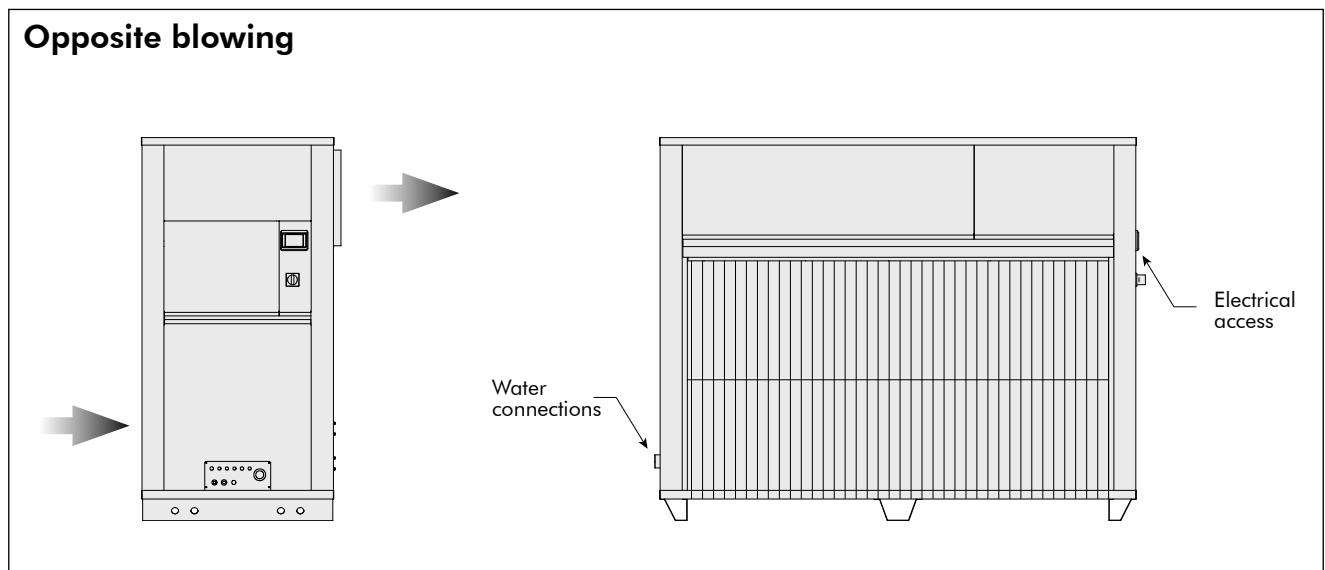
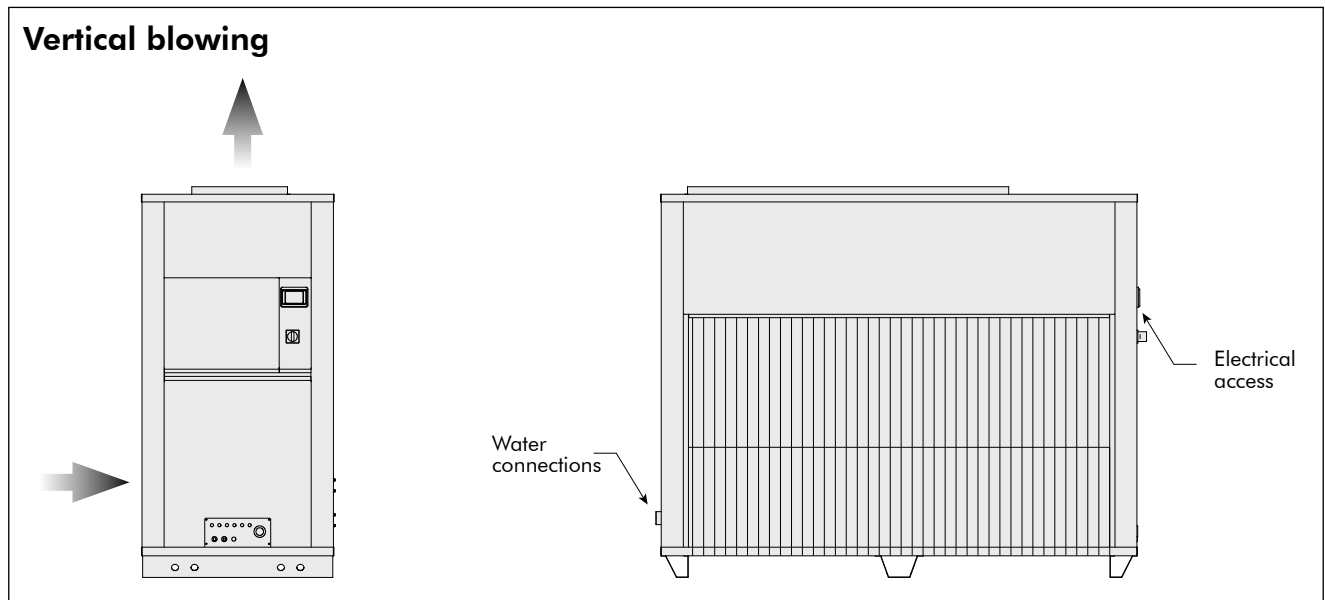
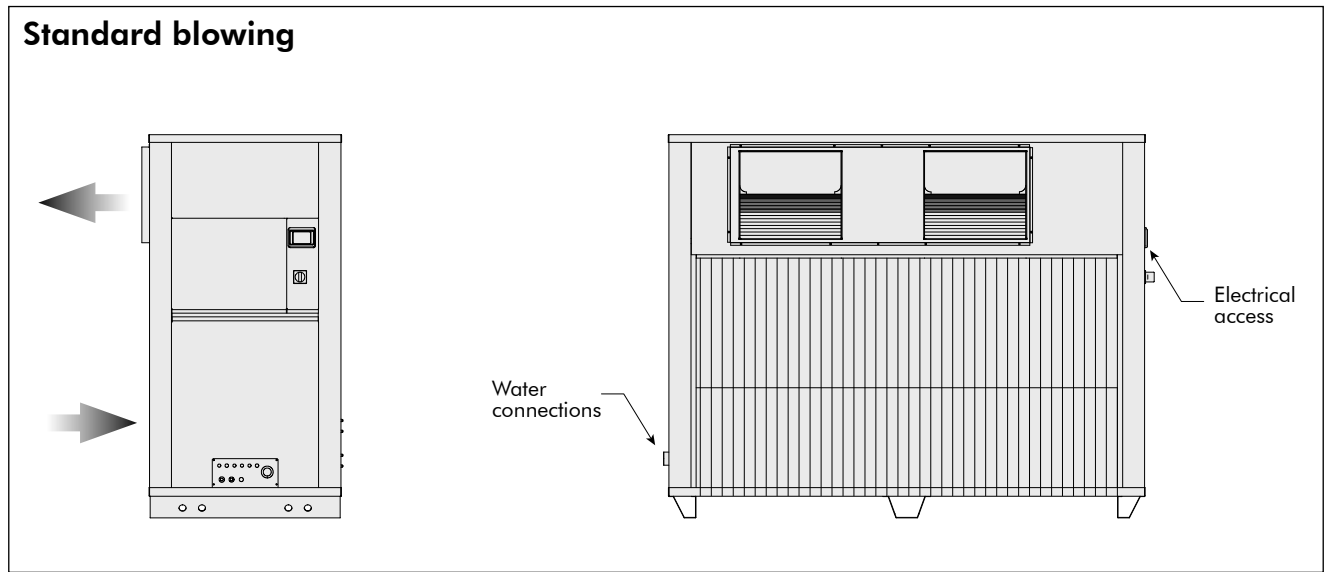

# Water Connections

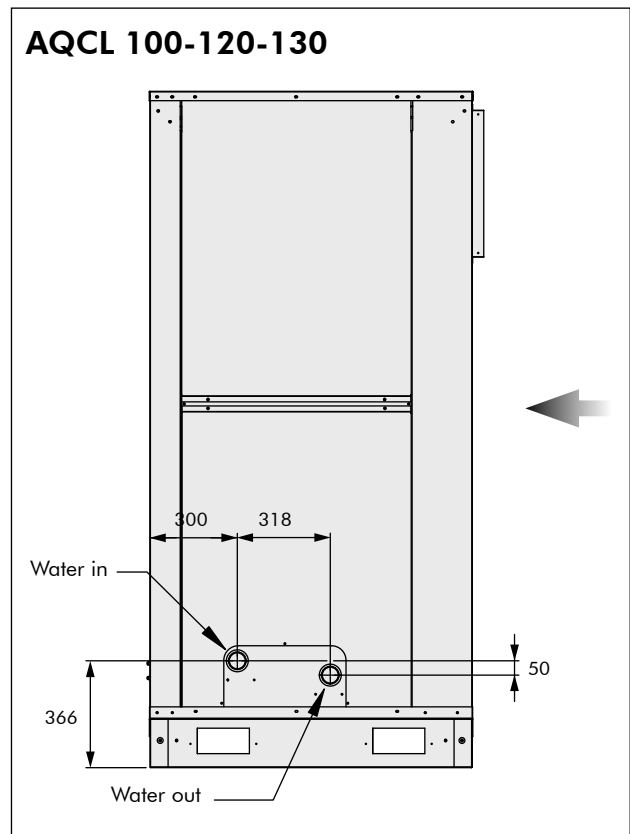
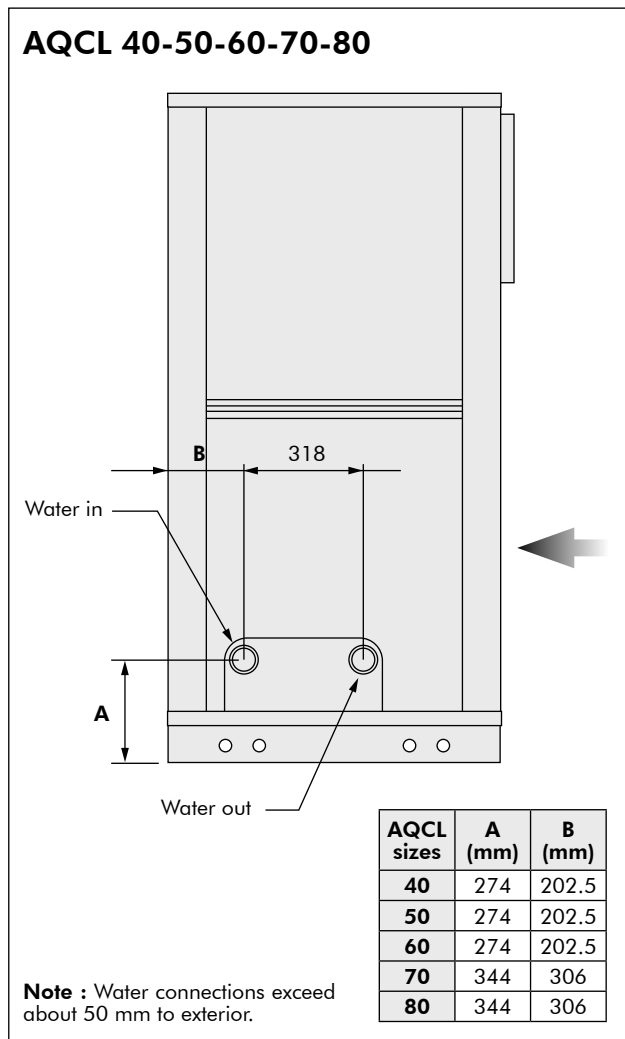
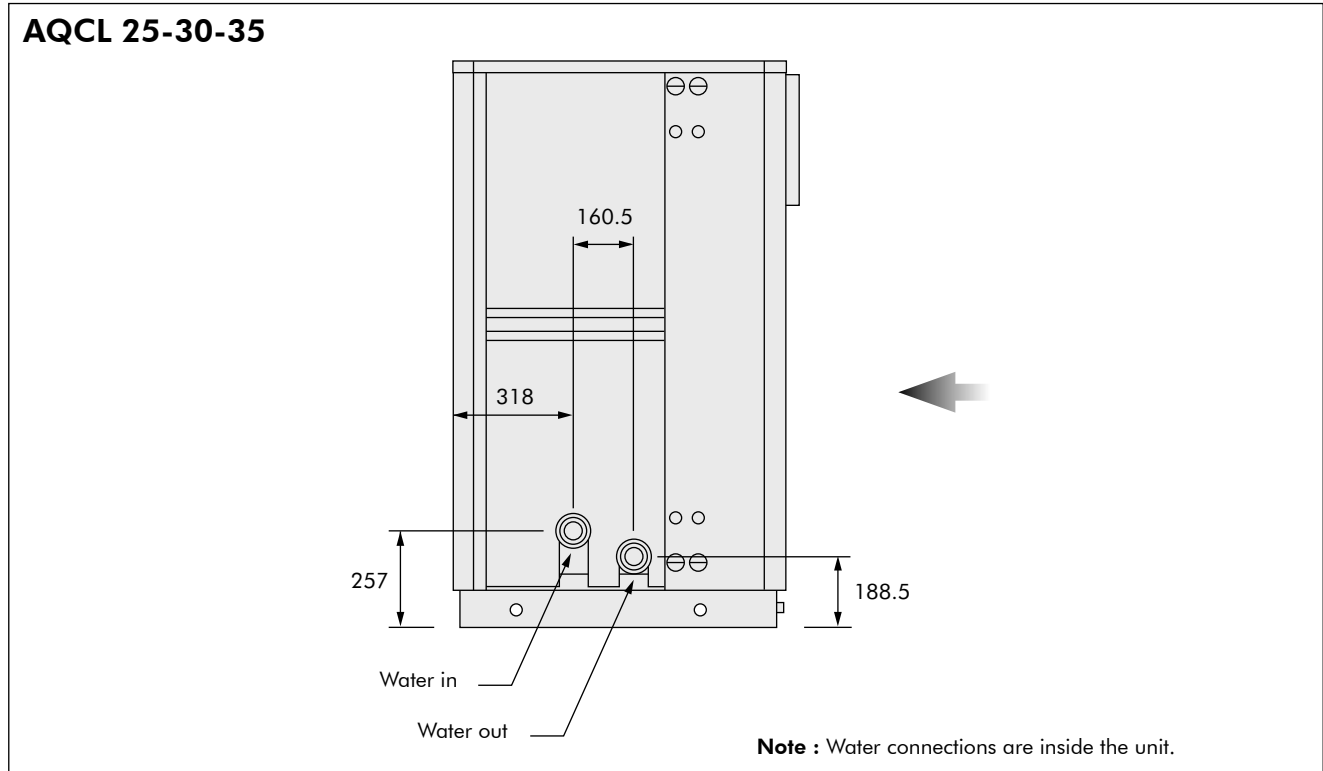

## Minimum Clearance Around the Unit

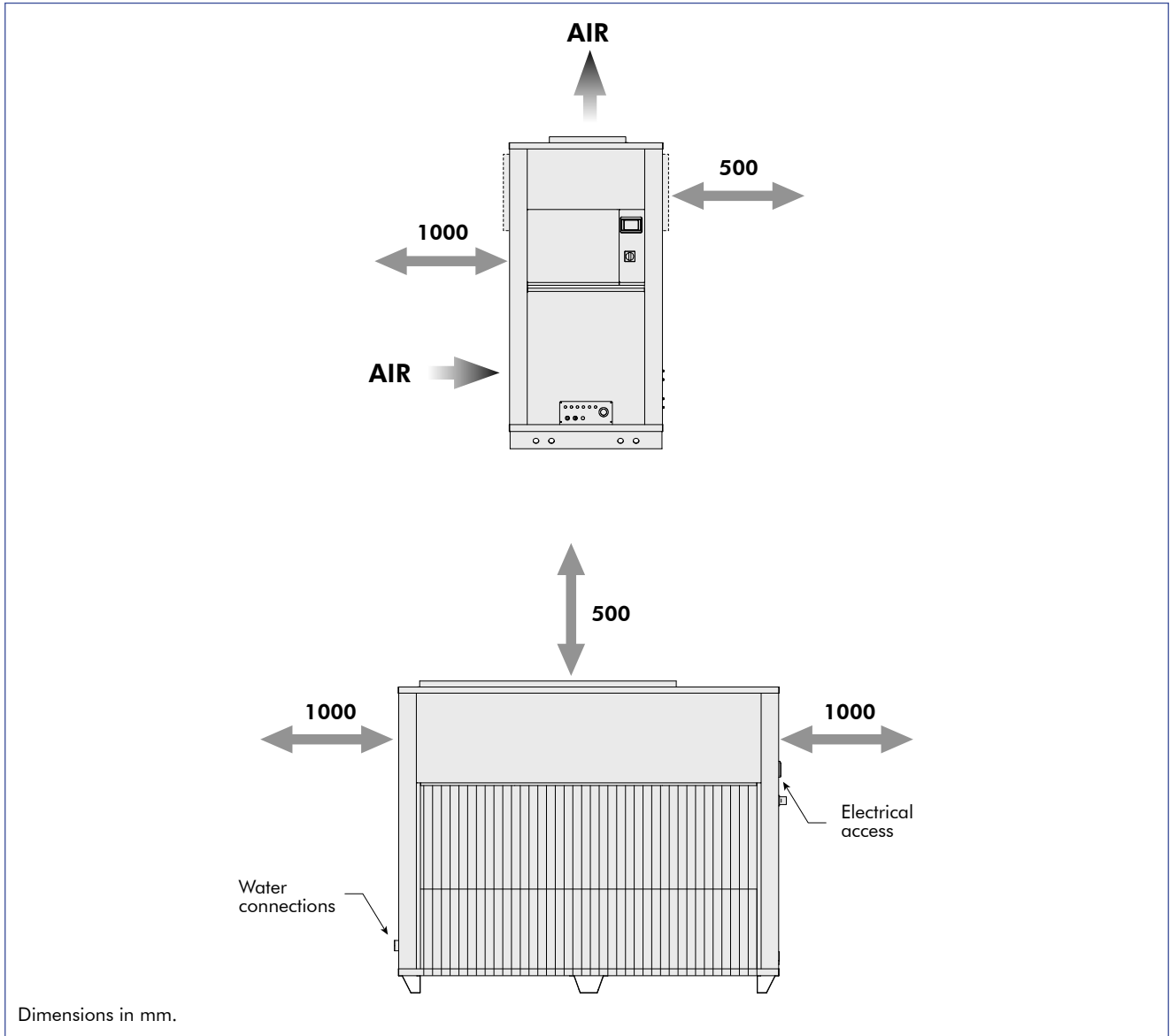

*As part of our ongoing product improvement programme, our products are subject to change without prior notice. Non contractual photos.*



**ACE**  
Industrie

