

Premi@ir

PR 20-360



English

Français

Air Handling Units
Centrales de traitement d'air

IOM PR-W.1GBF
Date : **March 2004 / Mars 2004**
Supersedes / Annule et remplace : **None / Aucun**



1 - Introduction

The purpose of this manual is to give the rules of installation, startup, operation and maintenance to the users of the air handling units.

It doesn't provide a full description of all maintenance works assuring the long life and the reliability of this type of equipment. Only the services of a qualified technician can assure a reliable and durable running of the unit.

2 - Safety Precautions

Before installing the machine, please read the following safety precautions carefully :

Warning

The installation, the commissioning and the maintenance of these machines must be performed by qualified personnels who are familiar with local codes and regulations and experienced with this type of equipment.

Warning

All field wiring must be installed in accordance with local electric norms.

Warning

Insure that the power supply of the unit is in conformity with the available power supply before undertaking the electric wiring.

Warning

The unit must BE GROUNDED to avoid the risks due to a defect of insulation.

Warning

All wiring must not touch the source of heat or the moving parts of the fan-motor assembly.

Caution

The handling of the unit must be achieved by using the lifting systems suitable for the size and the weight of the unit.

Caution

NEVER penetrate in a fan section or stay in the unit when the fan is running.

Caution

DISCONNECT power to the fan-motor assembly before working on this one. Take the fuse with you if the disconnect switch is not close by.

Caution

DISCONNECT power to the electric heater battery before working on or close to this one. If the battery was in operation, wait that the heat is dissipated.

Caution

DO NOT open a door before the fan is completely stopped. The pressure generated by the rotation of the fan can project or open brutally the access door on the person opening this one.

Caution

DO NOT work on dampers before these are blocked and disconnected.

Caution

MAKE SURE that the fan is well fixed before working on this one.

Caution

DO NOT restart the unit before having checked that all components have been reset.

Caution

NEVER pressurize the unit beyond these specifications and make certain that the dampers are open.

3 - Inspection and Storage

Upon receipt of the material on site, all items should be carefully checked against the bills of lading to be sure all crates and cartons have been received.

All damage visible on the units or on the packings as well as all mistake of delivery must make the subject of a reserve notified on the delivery note of the carrier.

Send within 48 hours a registered letter to the carrier mentioning precisely the damages occurred; a copy of this letter shall be sent to constructor or its representative.

If the units must not be immediately installed, it is strongly recommended to leave them inside their packing and to store them in a clean and dry place.

4 - Lifting and Handling

The good method of handling depends on the equipment, the size of the shipping sections, their final destination.

Figures 1 and 2 show the different possibilities that are offered.

Use a spreader to prevent damage to the unit cabinetry.

Before hoisting into position, test lift to insure stability and balance. Avoid twisting or uneven lifting of the units.

Special care should be taken when handling the fan section. All fans are dynamically balanced before leaving the plant. Rough handling, however, can cause misalignment or a sprung shaft. Fans and shaft should be carefully inspected before unit installation to make sure this has not happened.

The coil sections as well as the mixing sections having dampers should also be handled with special care. Dampers are set and inspected before leaving the plant but should be checked on arrival to the job to be sure the bell arms and connecting rod setscrews have not become loose in shipment.

All these sections have been inspected before leaving the factory. It is therefore important to insure that no bolts, screws or other fixing system are loosened or missing before the commissioning.

Caution

All panels of unit cabinetry are coated with a removable plastic film to protect them during the transportation.

This protection should be removed as soon as the units are received on site, at the risk of meeting later on with difficulties of peeling caused by sun radiations and bad weathers.

Figure 1

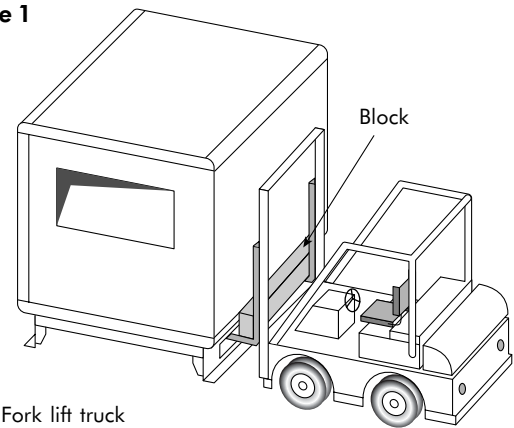
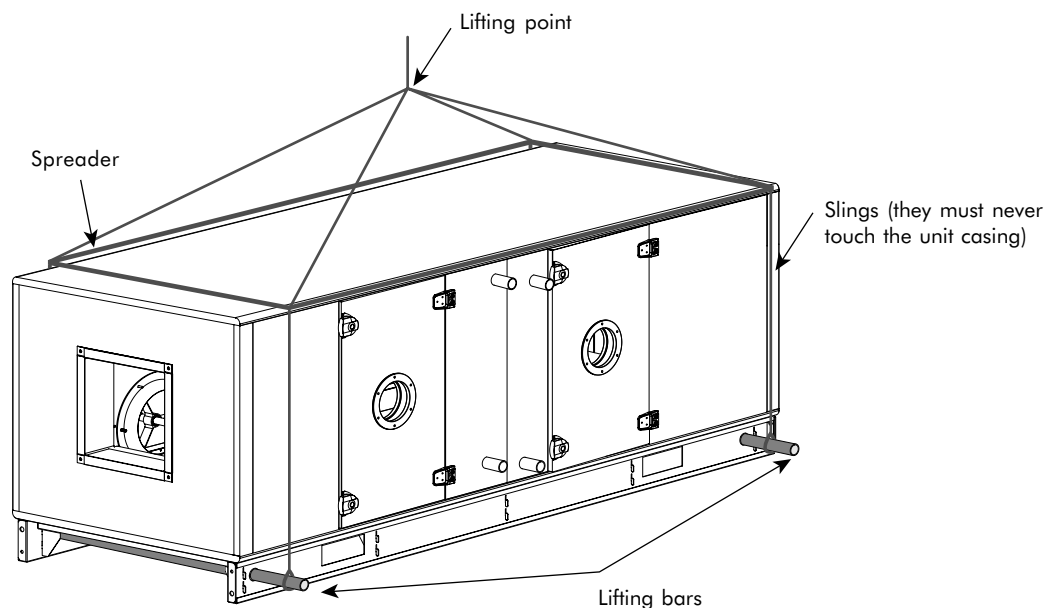
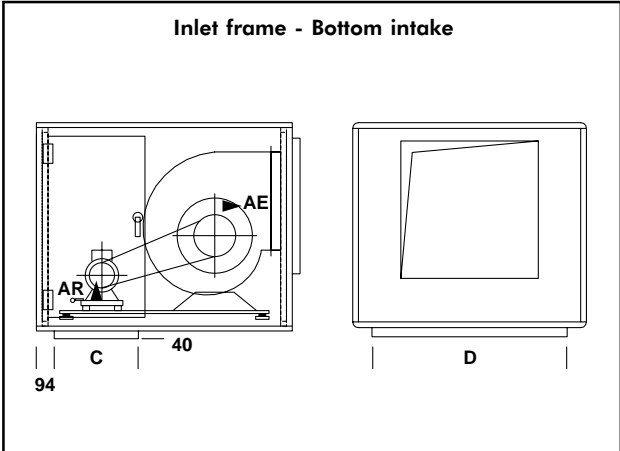

Figure 2



5 - Dimensions for Ductwork Connections

Inlet frame



Inlet flexible connector

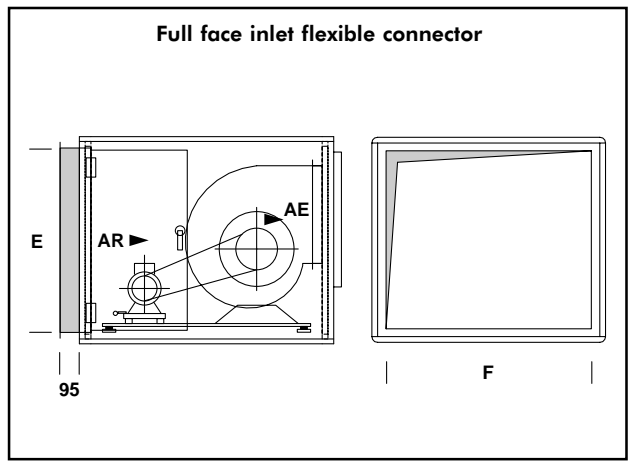
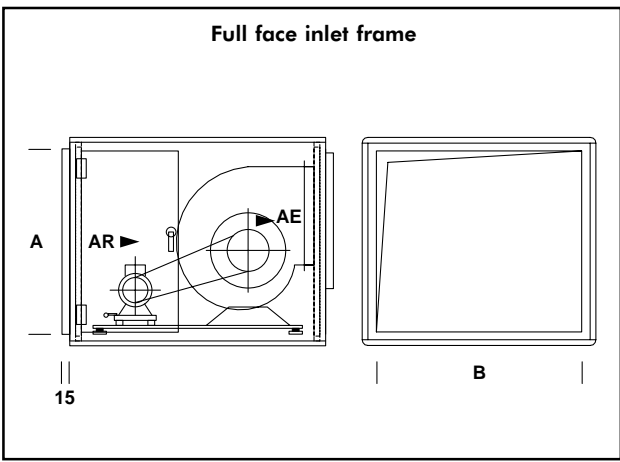
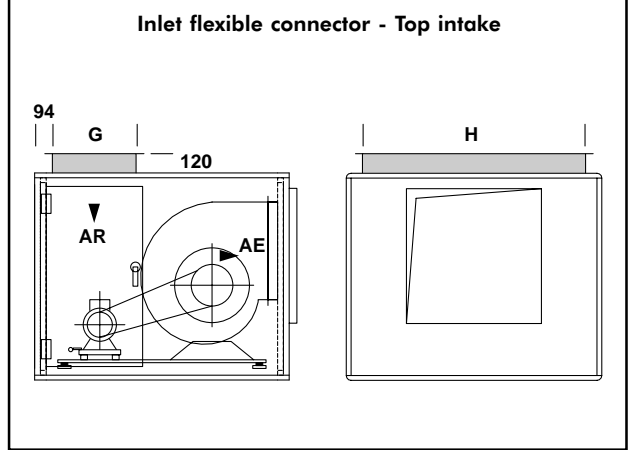
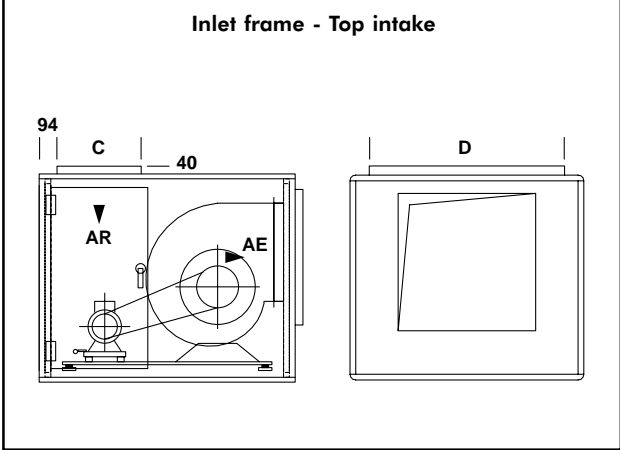
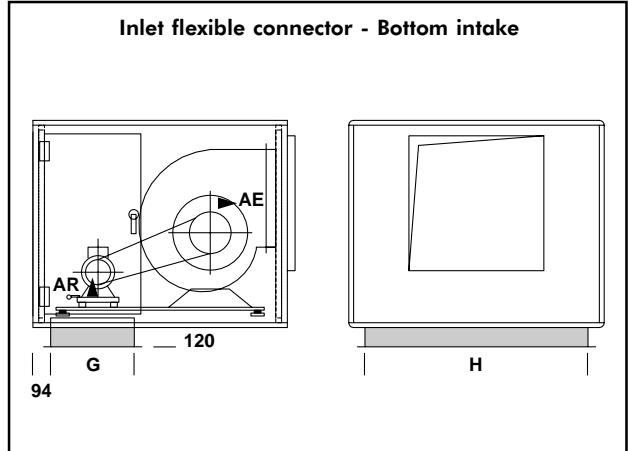

Sizes	20	40	60	90	120	160	200	240	300	360
A	417	777	777	777	957	1287	1287	1287	1577	1877
B	591	591	896	1201	1201	1201	1506	1811	1811	1811
C	234	334	334	334	434	534	532	532	532	697
D	547	547	852	1157	1157	1157	1462	1767	1767	1767
E	417	777	777	777	957	1287	1287	1287	1577	1877
F	591	591	896	1201	1201	1201	1506	1811	1811	1811
G	234	334	334	334	434	534	532	532	532	697
H	547	547	852	1157	1157	1157	1462	1767	1767	1767

A, B, C, D : Exterior dimensions (mm).

E, F, G, H : Interior dimensions (mm).

5 - Dimensions for Ductwork Connections (cont'd)

Discharge standard frame

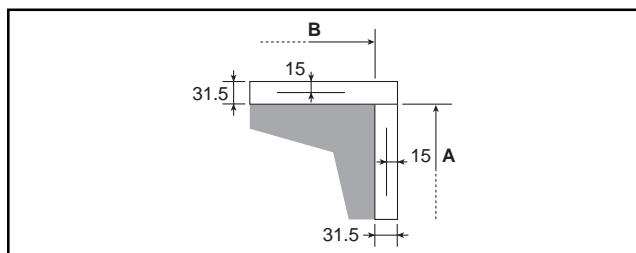
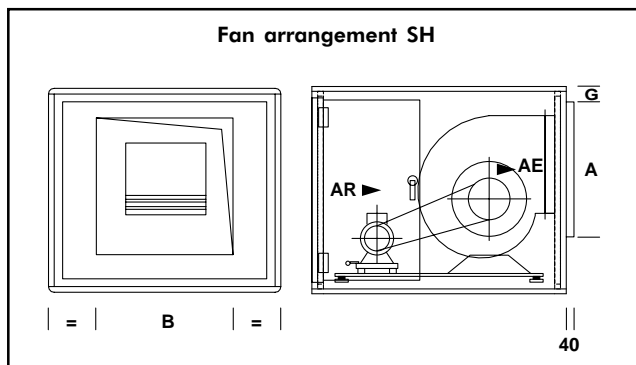
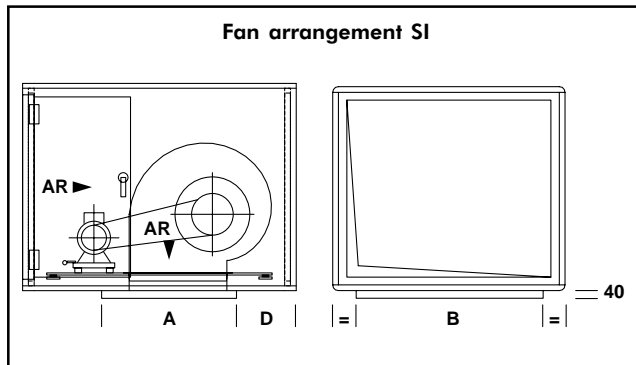
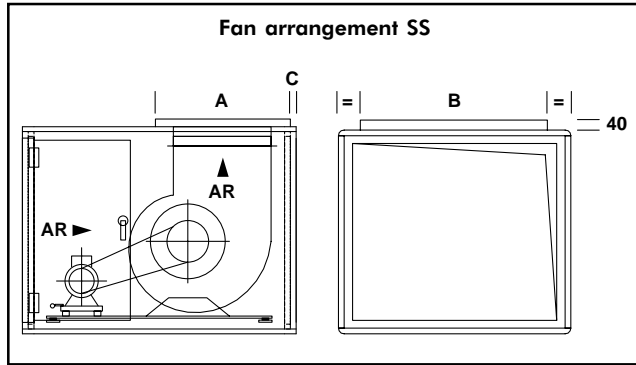

Discharge flexible connector

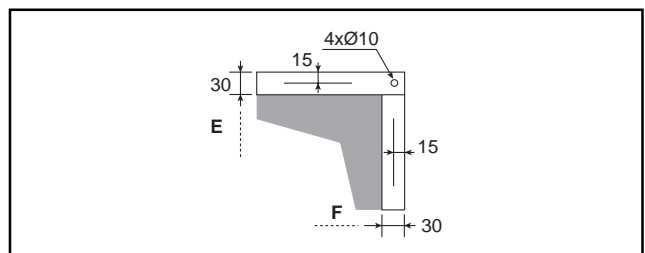
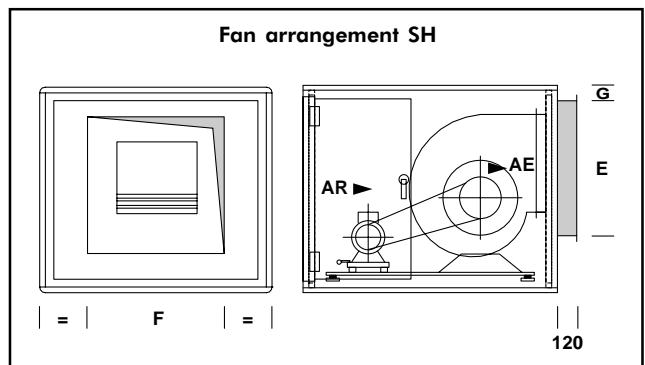
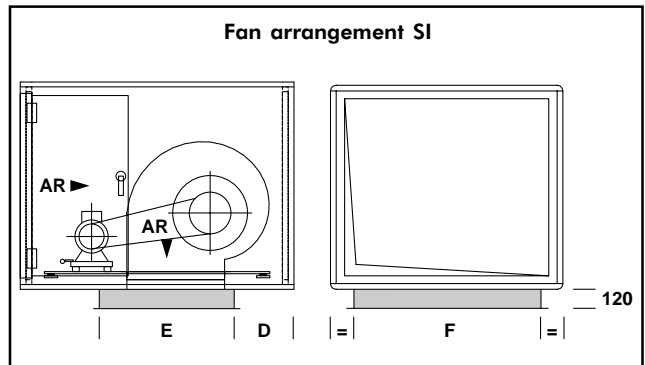
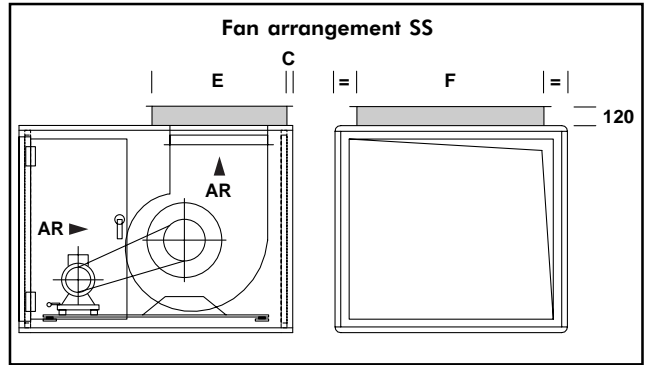

Sizes	20	40	60	90	120	160	200	240	300	360
A	400	500	600	600	800	800	900	1000	1100	1200
B	400	500	600	600	800	800	900	1000	1100	1200
C	30	30	30	30	30	30	30	30	30	30
D	100	250	250	250	250	250	350	350	450	450
E	400	500	600	600	800	800	900	1000	1100	1200
F	400	500	600	600	800	800	900	1000	1100	1200
G	40	230	130	130	100	320	220	55	58	58

A, B, C, D : Exterior dimensions (mm).

E, F, G : Interior dimensions (mm).

5 - Dimensions for Ductwork Connections (cont'd)

External shut-off damper

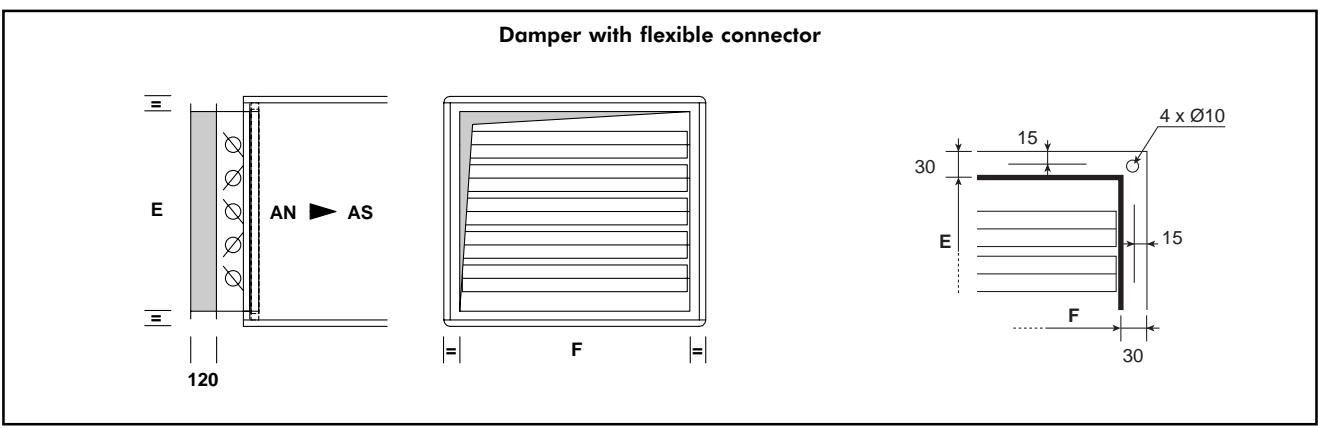
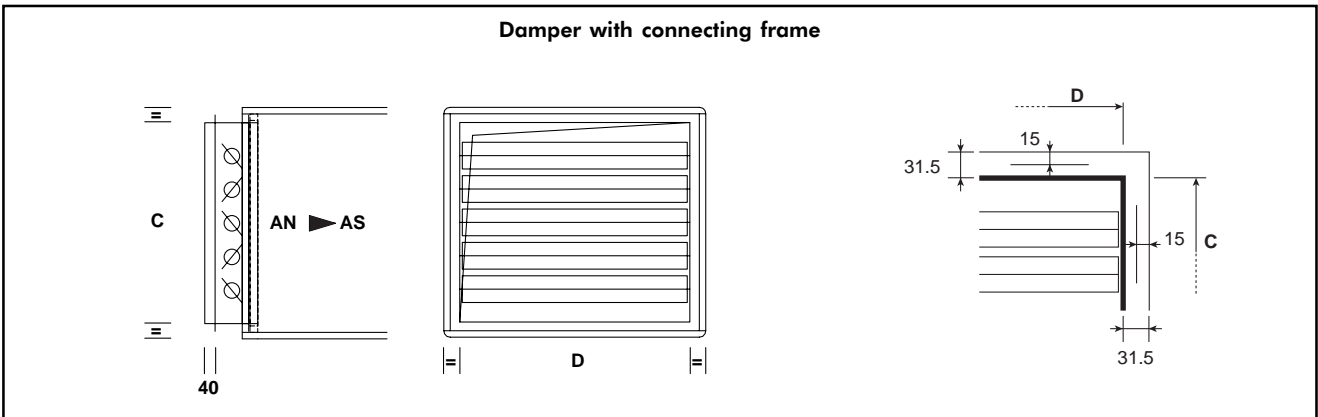
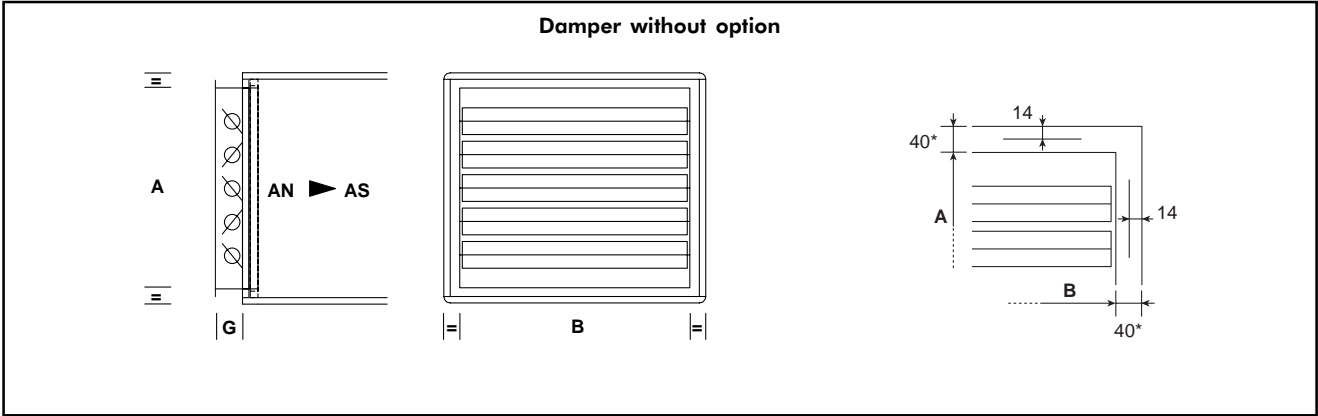

Sizes	20	40	60	90	120	160	200	240	300	360
A	395	755	755	755	935	1265	1265	1265	1555	1855
B	569	569	874	1179	1179	1179	1484	1789	1789	1789
C	417	777	777	777	957	1287	1287	1287	1577	1877
D	591	591	896	1201	1201	1201	1506	1811	1811	1811
E	417	777	777	777	957	1287	1287	1287	1577	1877
F	591	591	896	1201	1201	1201	1506	1811	1811	1811
G**	105	105	105	105	105	105	160	160	160	160

* = 36 if Class 4 damper, add 8 mm to A & B.

** PR20 to PR160 : G = 160 if Class 4 damper.

A&B : damper interior dimensions **C&D** : frame exterior dimensions **E&F** : flexible connector interior dimensions.

5 - Dimensions for Ductwork Connections (cont'd)

Standard 2-way mixing box

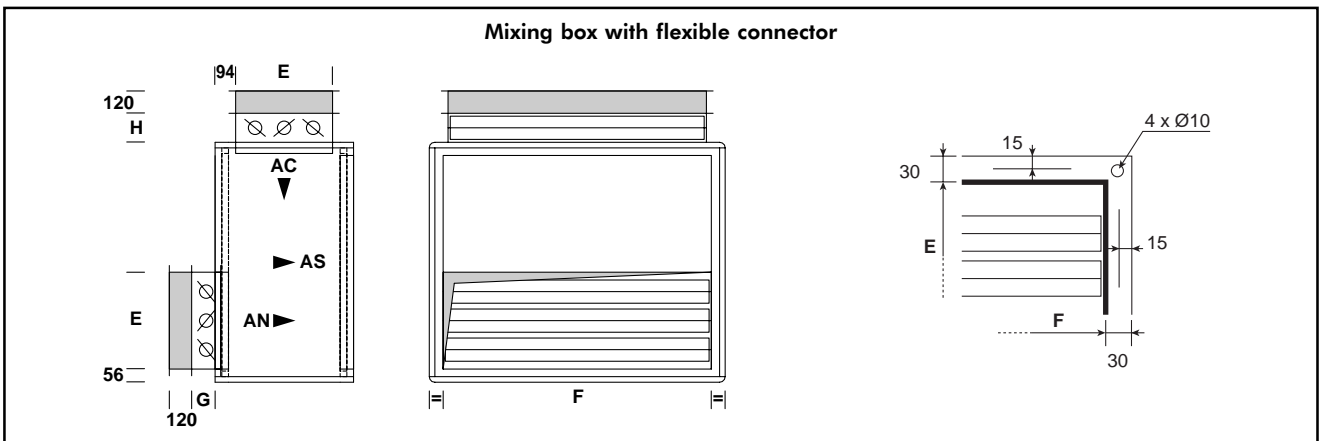
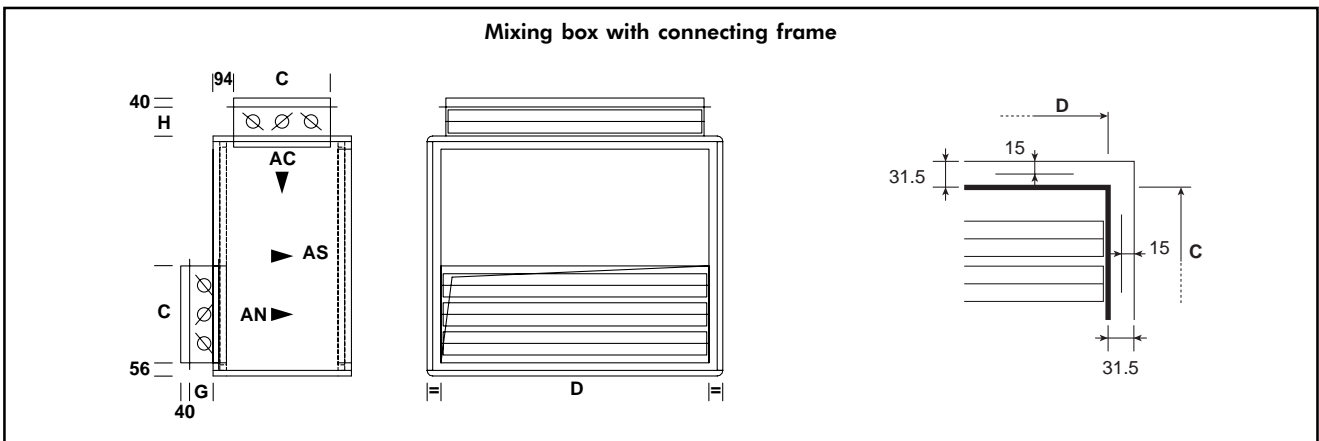
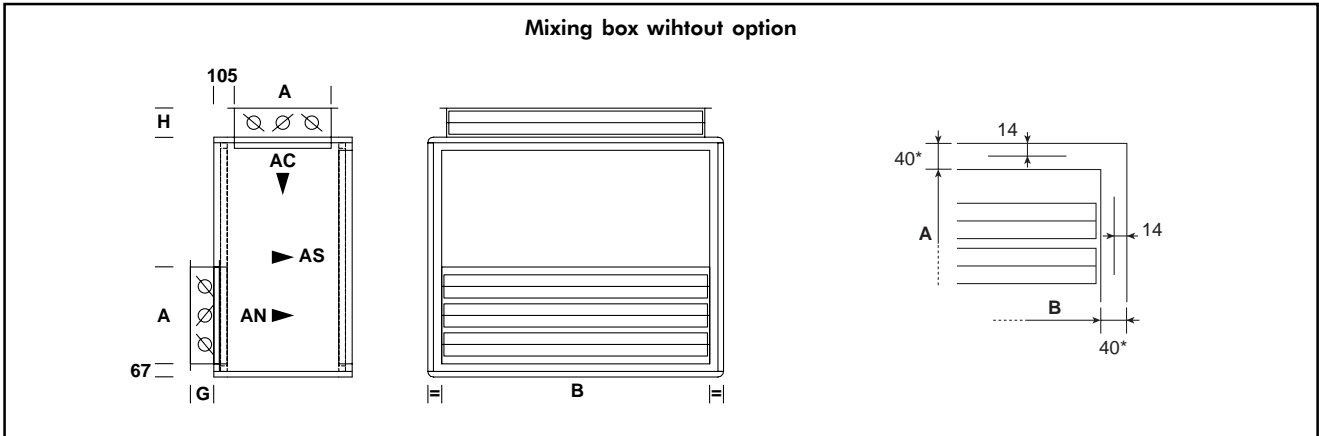

Sizes	20	40	60	90	120	160	200	240	300	360
A	212	312	312	312	412	512	510	510	510	675
B	525	525	830	1135	1135	1135	1440	1745	1745	1745
C	234	334	334	334	434	534	532	532	532	697
D	547	547	852	1157	1157	1157	1462	1767	1767	1767
E	234	334	334	334	434	534	532	532	532	697
F	547	547	852	1157	1157	1157	1462	1767	1767	1767
G**	105	105	105	105	105	105	160	160	160	160
H***	130	130	130	130	130	130	185	185	185	185

* = 36 if Class 4 damper, add 8 mm to A & B.

** PR20 to PR160 : G = 160 if Class 4 damper.

***PR20 to PR160 : H = 185 if Class 4 damper.

A&B : damper interior dimensions **C&D** : frame exterior dimensions **E&F** : flexible connector interior dimensions.

5 - Dimensions for Ductwork Connections (cont'd)

2-way mixing box with side dampers

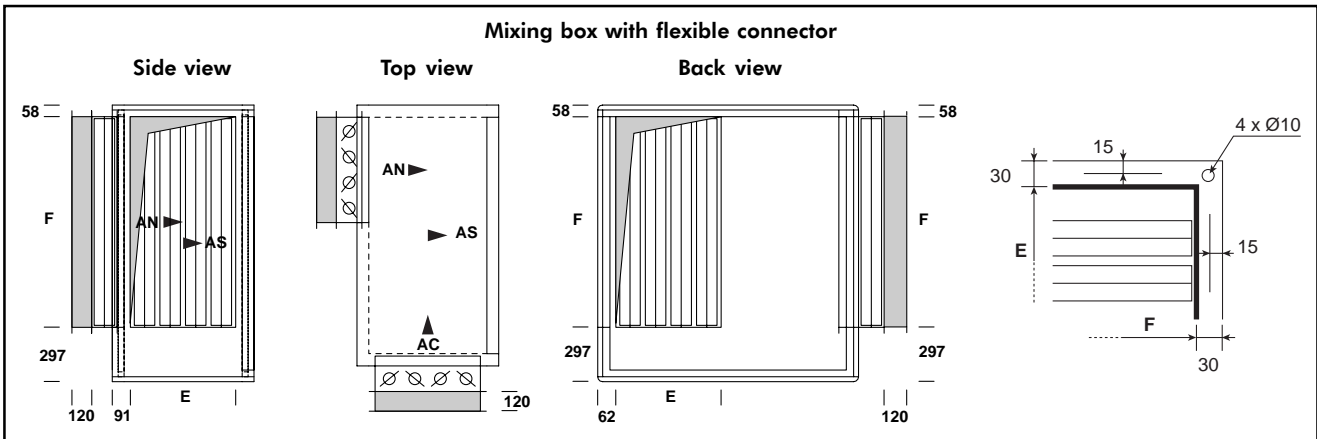
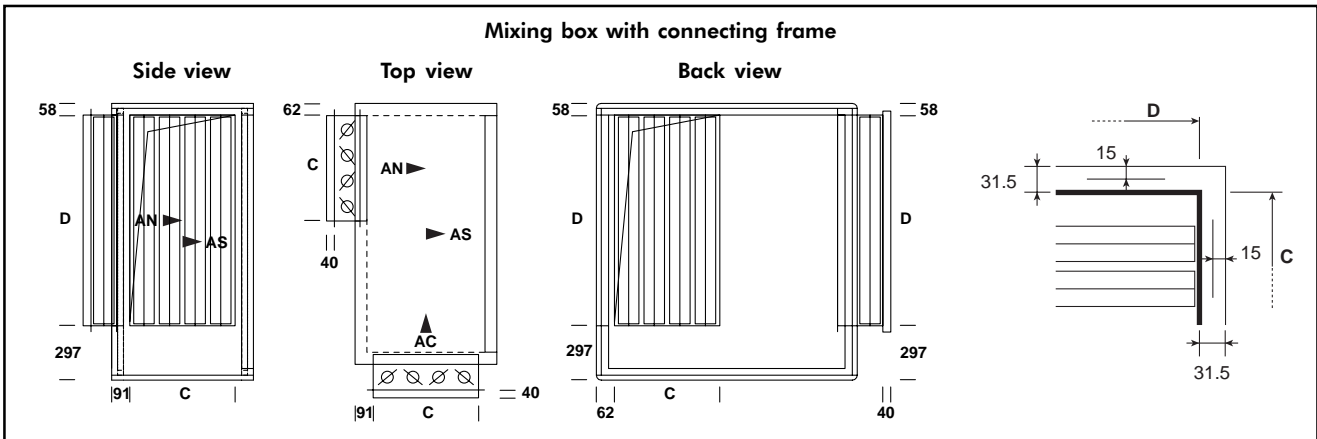
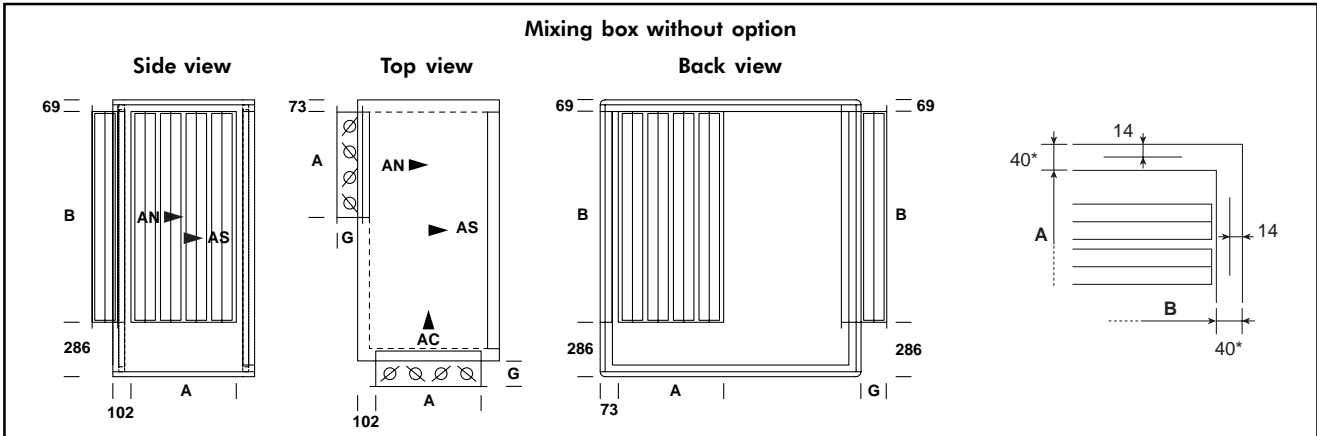

Sizes	20	40	60	90	120	160	200	240	300	360
A	315	315	415	515	515	515	515	515	515	715
B	180	540	540	540	720	1050	1050	1050	1340	1640
C	337	337	437	537	537	537	537	537	537	737
D	202	562	562	562	742	1072	1072	1072	1362	1662
E	337	337	437	537	537	537	537	537	537	737
F	202	562	562	562	742	1072	1072	1072	1362	1662
G**	105	105	105	105	105	105	160	160	160	160

* = 36 if Class 4 damper, add 8 mm to A & B.

** PR20 to PR160 : G = 160 if Class 4 damper.

A&B : damper interior dimensions **C&D** : frame exterior dimensions **E&F** : flexible connector interior dimensions.

Remark : if unit is supplied with a roof, the damper shafts are oriented downwards, otherwise they are oriented upwards.

5 - Dimensions for Ductwork Connections (cont'd)

Standard 3-way mixing box

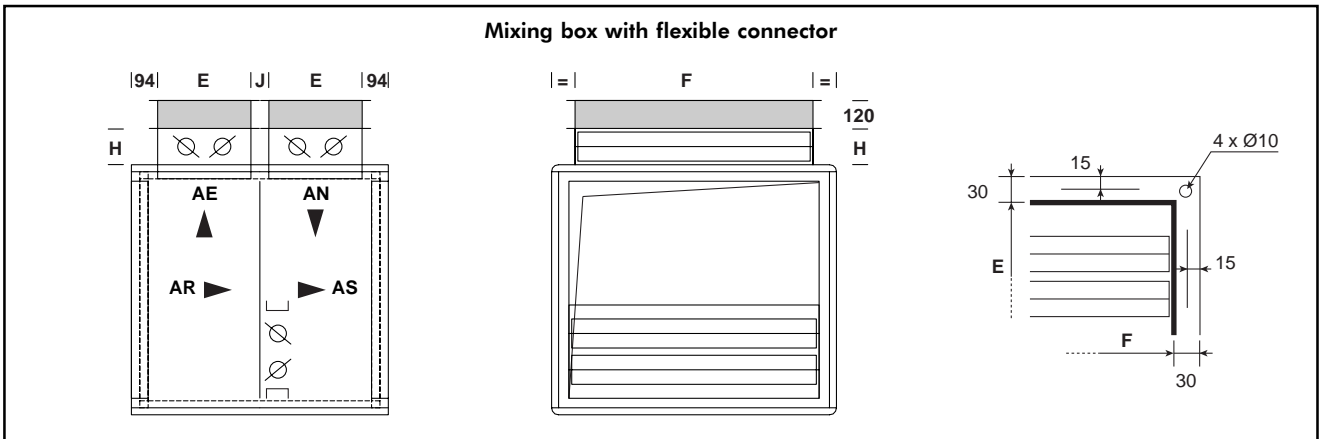
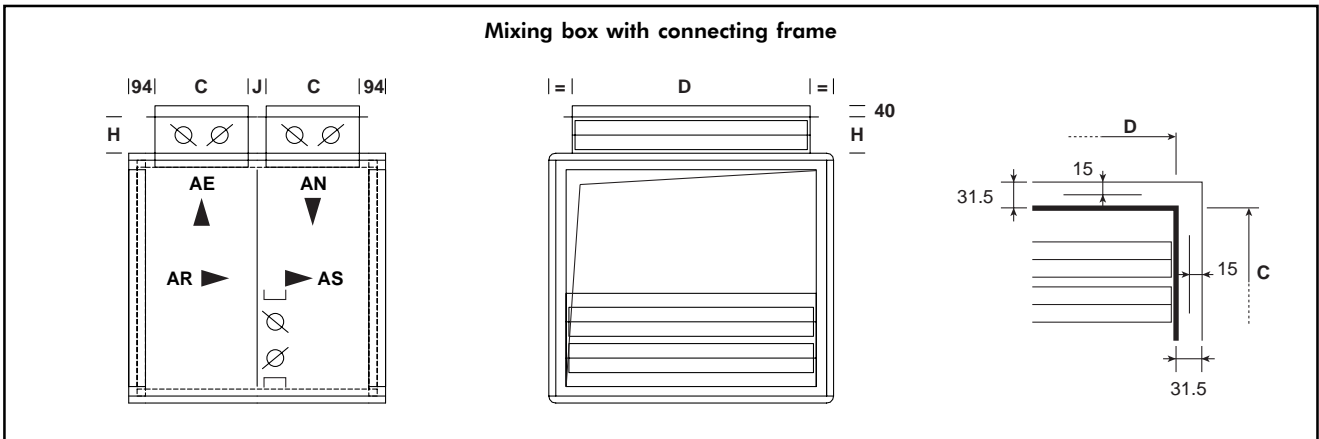
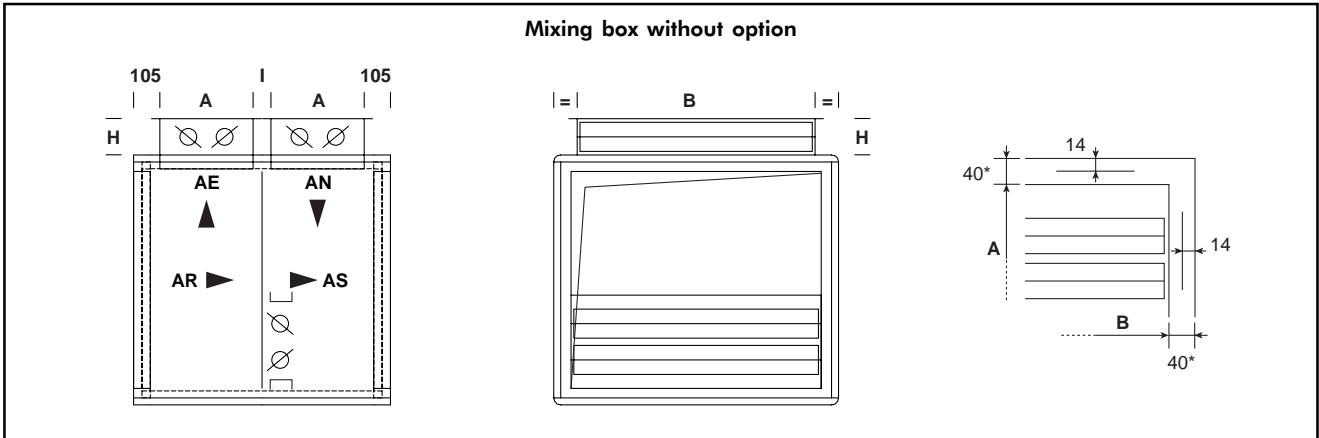

Sizes	20	40	60	90	120	160	200	240	300	360
A	212	312	312	312	412	512	510	510	510	675
B	525	525	830	1135	1135	1135	1440	1745	1745	1745
C	234	334	334	334	434	534	532	532	532	697
D	547	547	852	1157	1157	1157	1462	1767	1767	1767
E	234	334	334	334	434	534	532	532	532	697
F	547	547	852	1157	1157	1157	1462	1767	1767	1767
H**	130	130	130	130	130	130	185	185	185	185
I	86	86	86	86	86	86	90	90	90	160
J	42	42	42	42	42	42	46	46	46	116

* = 36 if Class 4 damper, add 8 mm to A & B.

** PR20 to PR160 : H = 185 if Class 4 damper.

A&B : damper interior dimensions C&D : frame exterior dimensions E&F : flexible connector interior dimensions.

5 - Dimensions for Ductwork Connections (cont'd)

3-way mixing box with side dampers

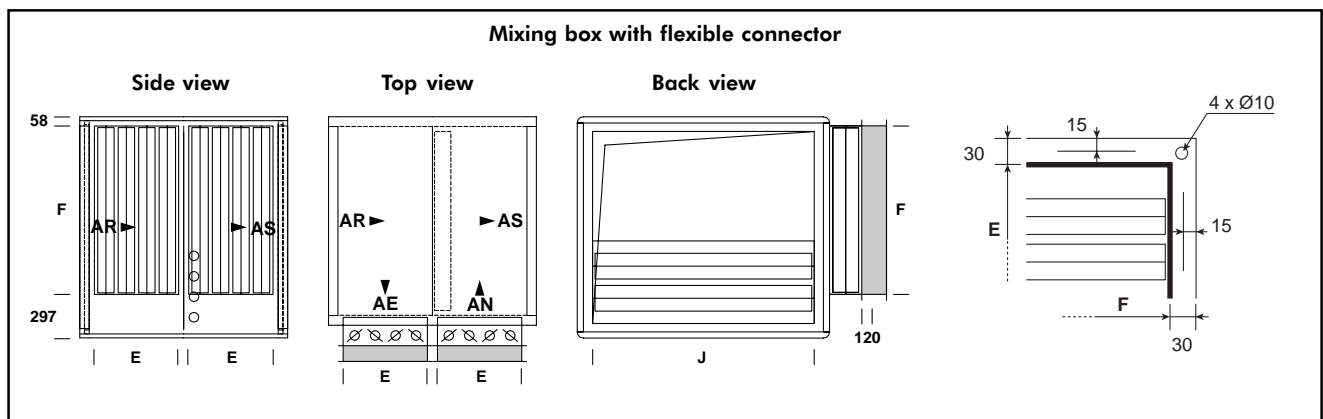
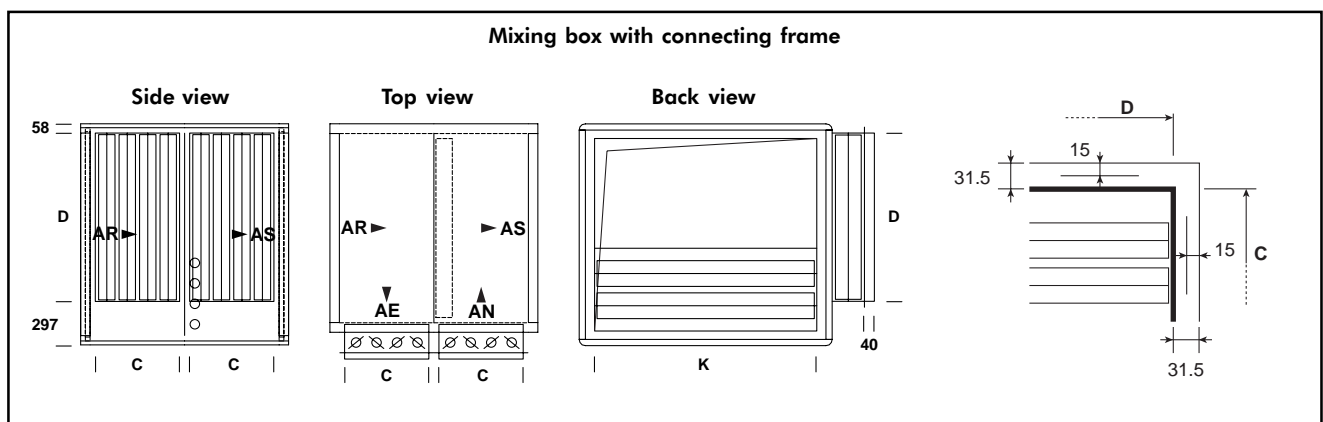
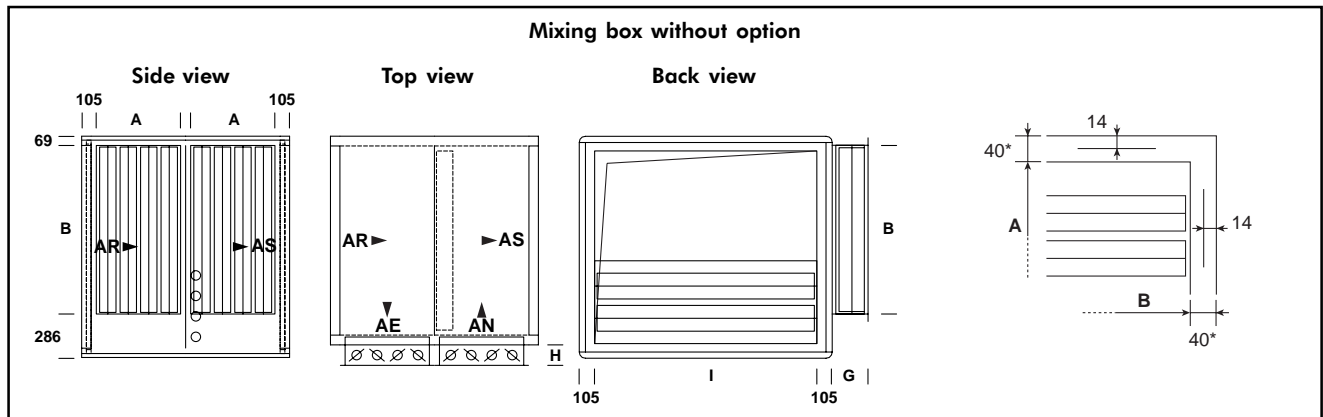

Sizes	20	40	60	90	120	160	200	240	300	360
A	315	315	415	515	515	515	515	515	515	715
B	180	540	540	540	720	1050	1050	1050	1340	1640
C	337	337	437	537	537	537	537	537	537	737
D	202	562	562	562	742	1072	1072	1072	1362	1662
E	337	337	437	537	537	537	537	537	537	737
F	202	562	562	562	742	1072	1072	1072	1362	1662
G**	105	105	105	105	105	105	160	160	160	160
H	130	130	130	130	130	130	185	185	185	185
I	525	525	830	1135	1135	1135	1440	1745	1745	1745
J	547	547	852	1157	1157	1157	1462	1767	1767	1767
K	547	547	852	1157	1157	1157	1462	1767	1767	1767

* = 36 if Class 4 damper, add 8 mm to A & B.

** PR20 to PR160 : G = 160 if Class 4 damper.

A&B : damper interior dimensions C&D : frame exterior dimensions E&F : flexible connector interior dimensions.

5 - Dimensions for Ductwork Connections (cont'd)

Vertical 3-way mixing box

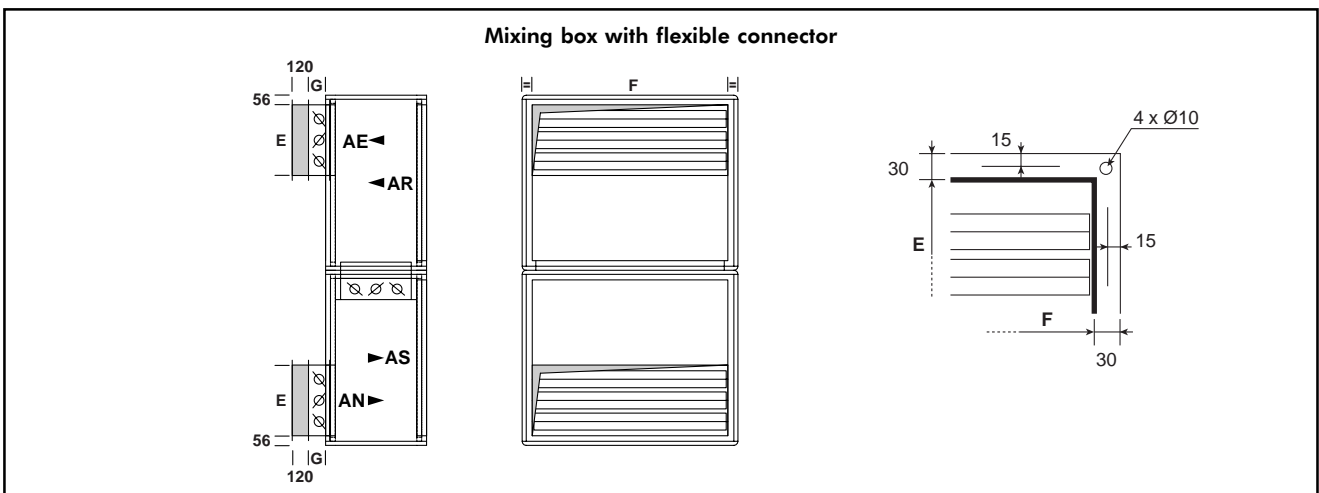
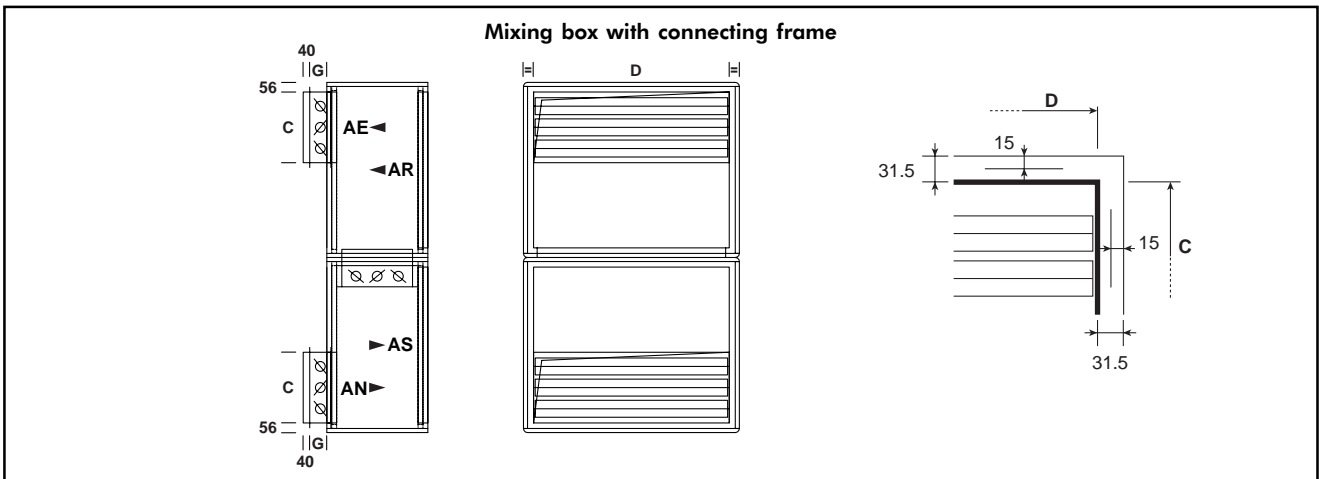
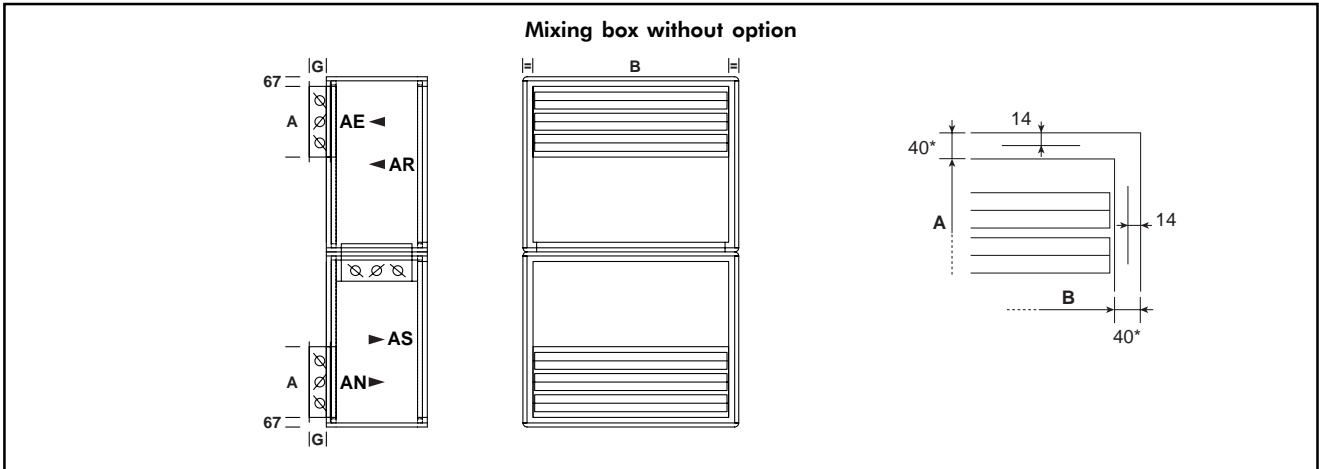

Sizes	20	40	60	90	120	160	200	240	300	360
A	212	312	312	312	412	512	510	510	510	675
B	525	525	830	1135	1135	1135	1440	1745	1745	1745
C	234	334	334	334	434	534	532	532	532	697
D	547	547	852	1157	1157	1157	1462	1767	1767	1767
E	234	334	334	334	434	534	532	532	532	697
F	547	547	852	1157	1157	1157	1462	1767	1767	1767
G**	105	105	105	105	105	105	160	160	160	160

* = 36 if Class 4 damper, add 8 mm to A & B.

** PR20 to PR160 : G = 160 if Class 4 damper.

6 - Definition of the Service Side

The service side is defined as the side where there are access to main functions (filters, fan-motor assembly, electric heater, inspection), access to accessories (pressure tapping points, manometers, disconnect switch, rods of dampers, etc.) and water connections (coils, condensate drain).
 The drawings below show the service sides defined for different air handling unit configurations.

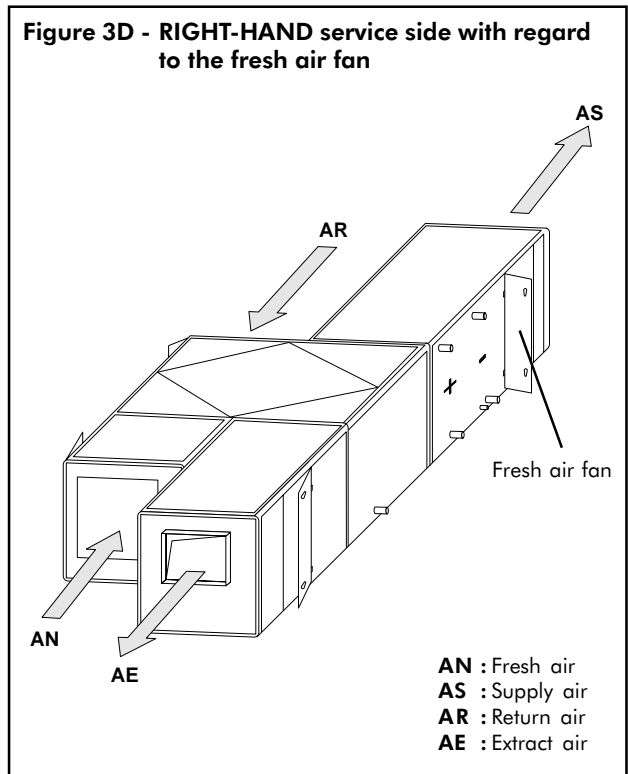
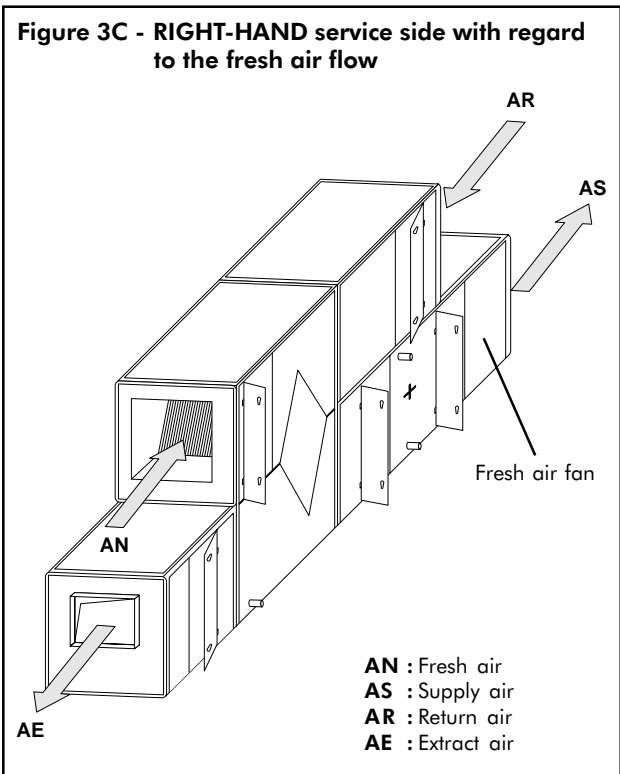
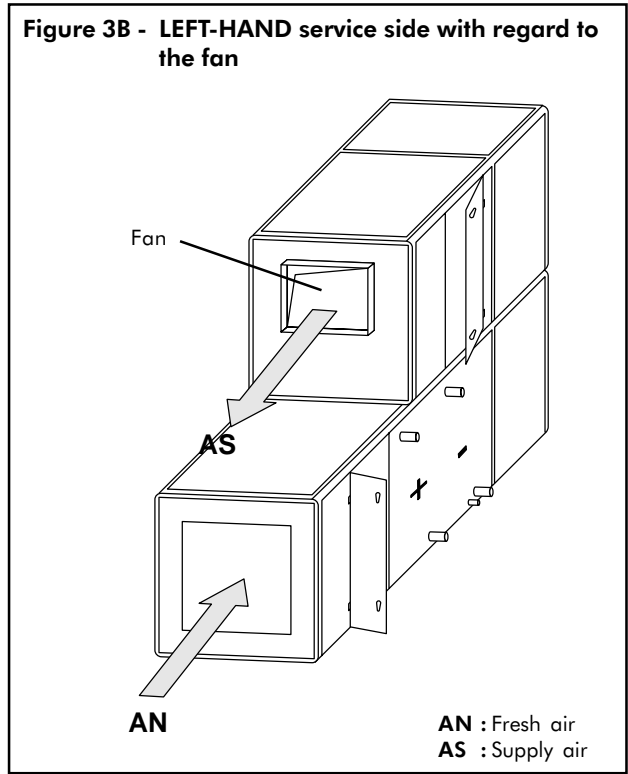
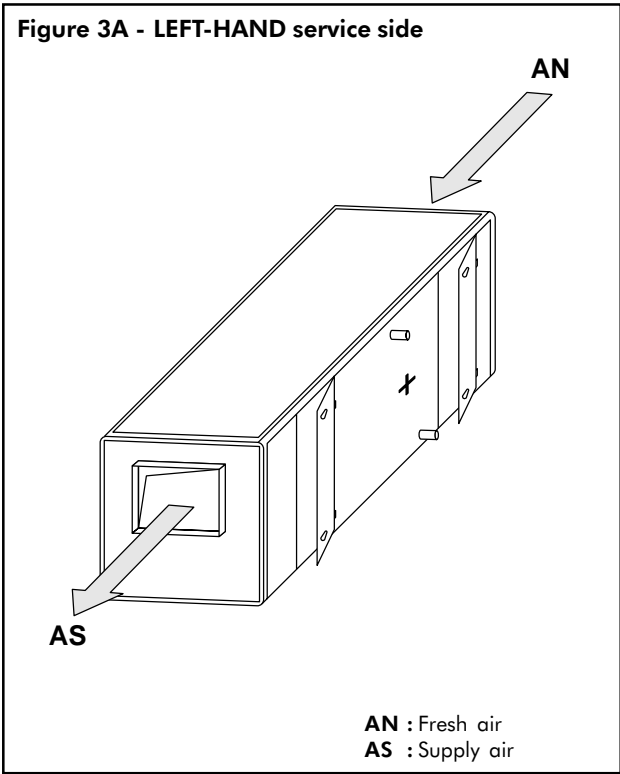

7 - Installation

7.1 - Unit placement

The installation of this equipment shall be in accordance with the regulations of authorities having jurisdiction and all applicable codes. It is the responsibility of the installer to determine and follow the applicable codes.

Sheet metal parts, self-tapping screws, clips, and such items inherently have sharp edges, and it is necessary that the installer exercises caution.

This equipment is to be installed only by an experienced installation company which employs trained personnel.

All units are equipped with a base frame under each transport section allowing their installation directly on a flat floor.

Every section must be levelled to facilitate the assembly of sections and insure proper drainage of condensate pan.

If vibration isolators are required, they have to be installed between unit base frame and floor, and correctly determined to be sure vibrations will be eliminated. It is important to ensure the surface evenness of the unit all along its length.

The installation of the unit must allow an easy access, necessary for maintenance purposes on the unit.

Adequate space should be left around the unit for piping coils and drains, maintenance such as filter replacement, drain pan inspection and cleaning, lubrication and belt adjustment. Sufficient space should be provided on the side of the unit for coil and fan removal should that become necessary. This space must be at least equal to the width of the unit (see fig. 4).

Flexible connectors should be used on the outlet and inlet duct connections of all units. They must be connected to the discharge duct collar or directly to frameworks of full face outlet and inlet sides.

Warning

Standard air handling units are designed for indoor installation. If they are to be installed outdoors, make sure the necessary equipment such as roof, rain hood, etc. are provided.

Caution

Air diffuser at fan discharge side will be supplied loose. Make certain that it will be installed at site (see installation diagrams below).

Installation of air diffuser (PR 20 to PR 300)

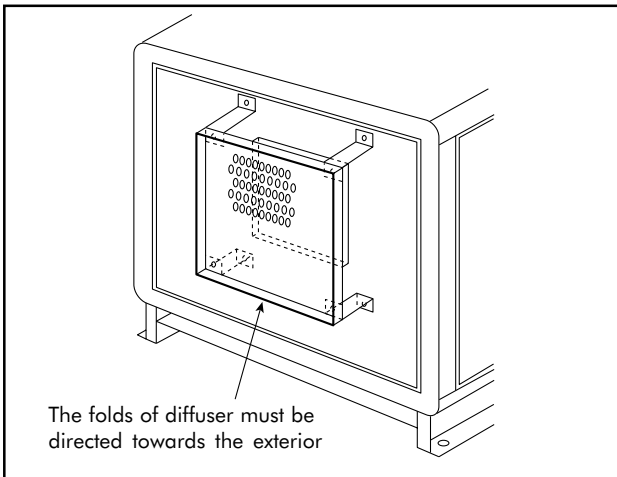

Installation of air diffuser (PR 360)

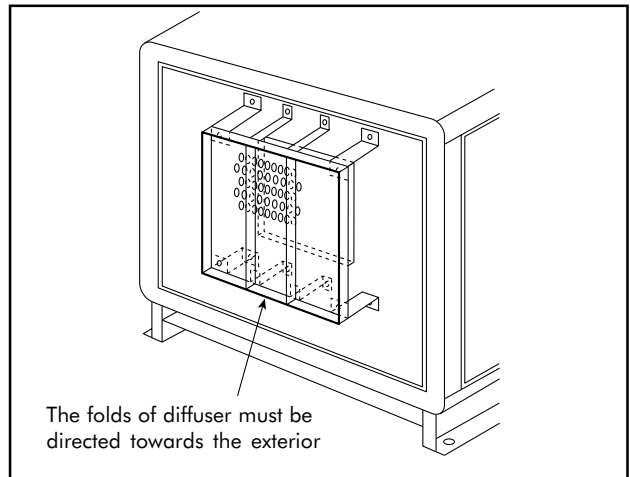

Service clearances

Figure 4 (top view)

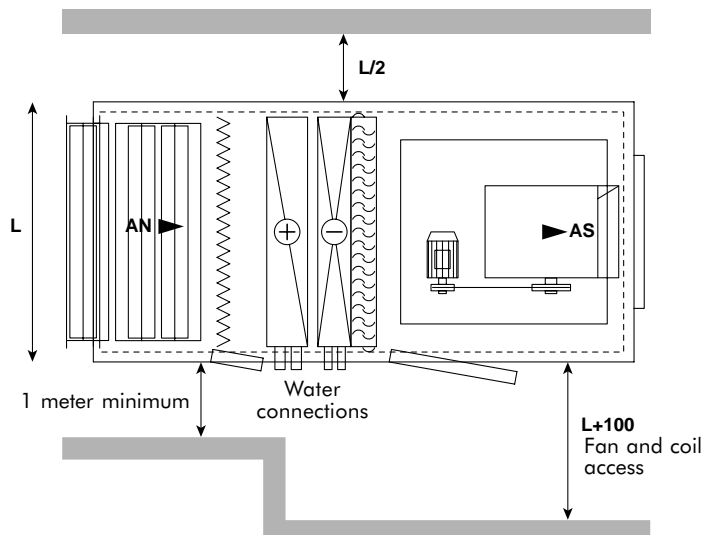

Sizes	Dimensions (mm)	
	L + 100	L/2
20	815	358
40	815	358
60	1120	510
90	1425	663
120	1425	663
160	1730	663
200	2035	815
240	2035	968
300	2035	968
360	2035	968

7 - Installation (cont'd)

Dimensions of the units

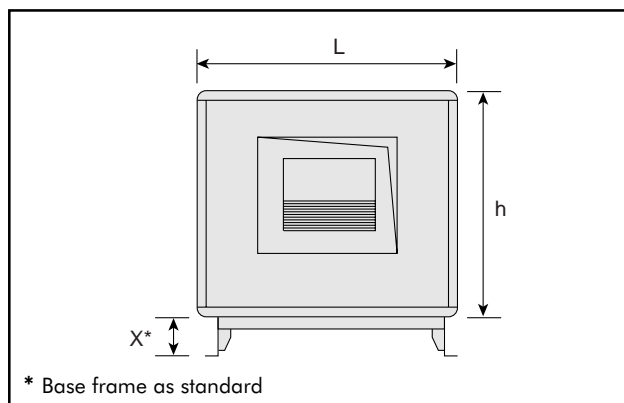

Sizes	Dimensions (mm)		
	L	h	X*
20	715	535	150
40	715	895	150
60	1020	895	150
90	1325	895	150
120	1325	1075	150
160	1325	1405	150
200	1630	1405	150
240	1935	1405	150
300	1935	1695	150
360	1935	1995	150

Dimensions of the base frames

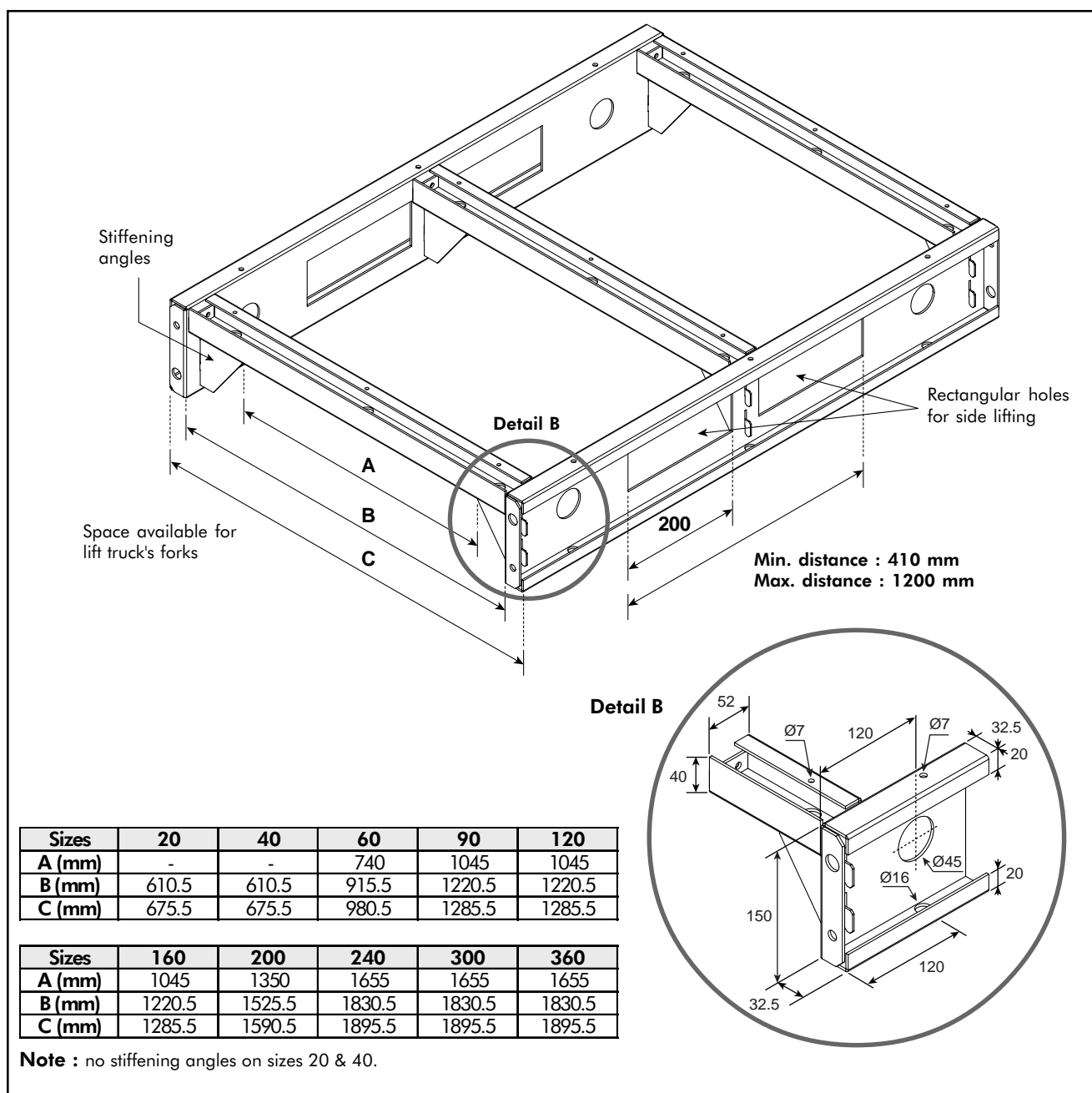

7 - Installation (cont'd)

7.2 - Assembly of the sections

Each transport section is supplied with assembly clamps externally fitted on the end frame of the section.

The assembly of the transport sections shall be performed as follows :

- 1 - Rig the unit into position and line transport sections up in direction of air flow. Sections must be pulled together to press the white joining gasket as shown in figure 5.
- 2 - Fasten the transport sections together using bolts as shown in figure 6.

Figure 5

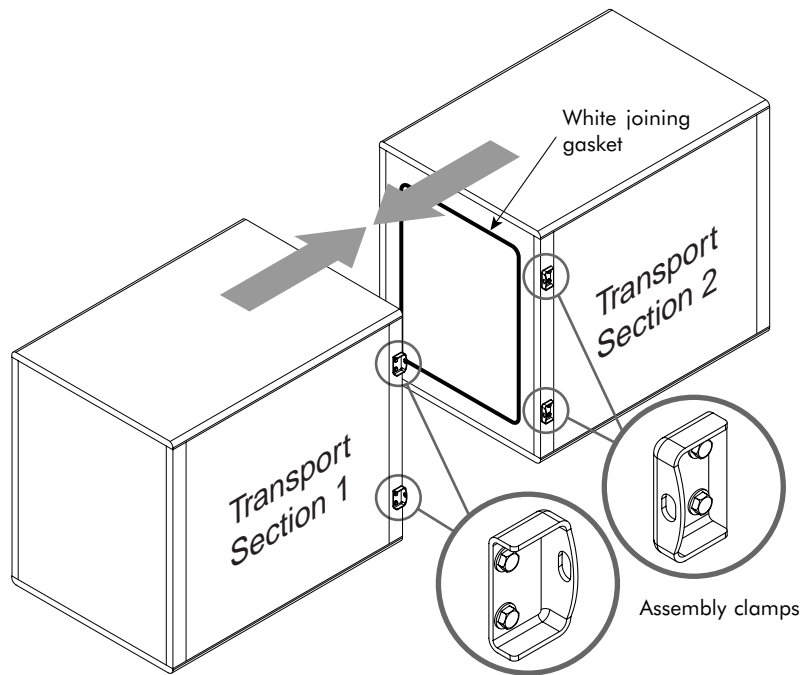
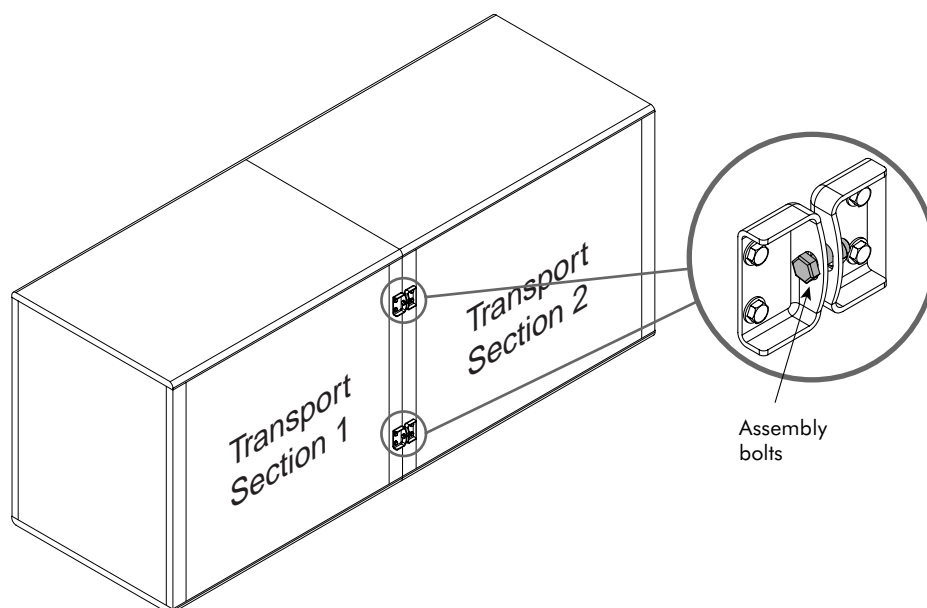
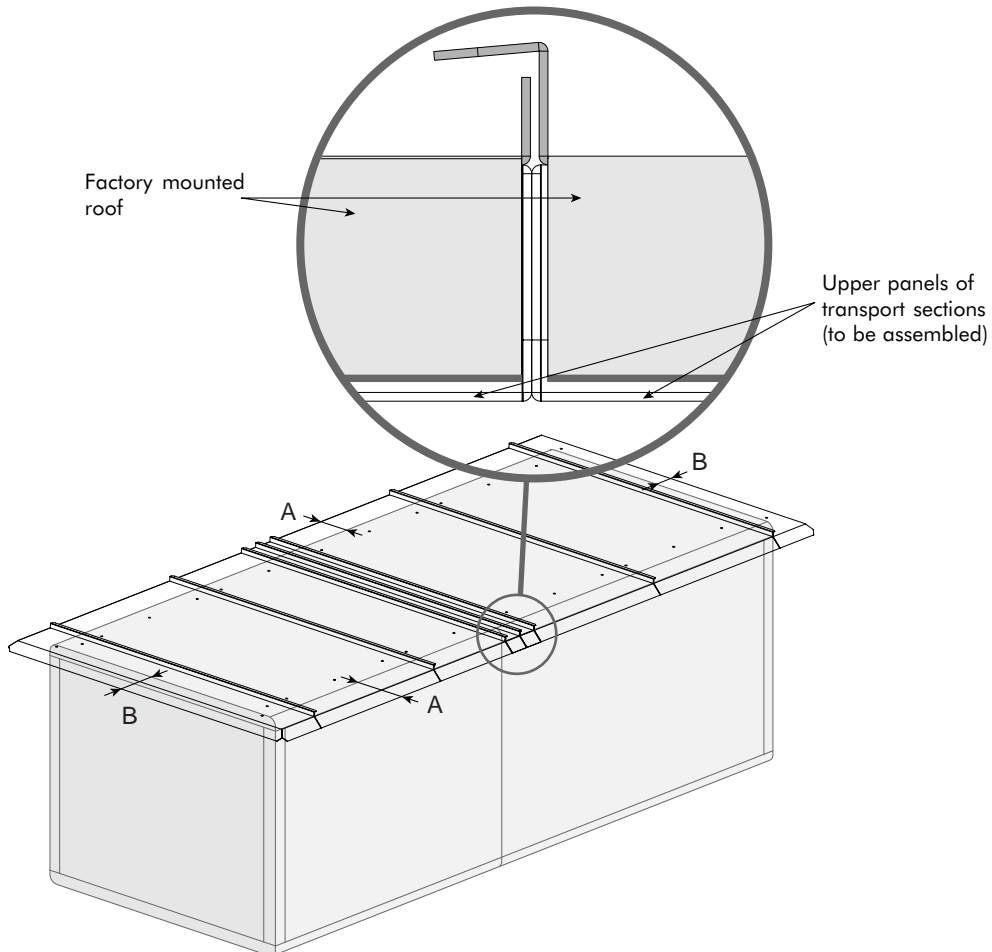

Figure 6



7 - Installation (cont'd)

7.3 - Roof



Roof extension around the unit :

A = 100 mm

B = 100 mm for in line air handling units, 120 mm for superposed air handling units.

7 - Installation (cont'd)

7.4 - Water piping

Water piping should be in accordance with accepted industry standards.

Undue stress should not be applied at the connection to coil headers. Pipework should be supported independently of the coils.

It is strongly recommended to install flexible isolators on water inlet and water outlet.

Water piping should have air vent and drain orifice, respectively located at the highest point and the lowest point of the installation.

Manual shutoff valves should be used on water inlet and water outlet of the coils to allow their maintenance.

Units must be levelled to insure proper operation and drainage of coils and drain pan.

Coil connections

Coils are equipped with steel headers of which the connections are extended to exterior of the unit.

Each coil has two connection orifices, one is at higher part and the other at lower part, permitting the same coil to be used for left hand or right hand water supply.

To insure an optimal heat transfer efficiency, water supply of coil should be arranged in counter-flow to the direction of air.

Water inlet and water outlet change from top to bottom orifice depending on whether the coil connection side is left hand or right hand (see figures 8A and 8B).



Warning

When installing couplings, do not apply undue stress to the connection extending through unit panel.

Use backup pipe wrench to avoid breaking the weld between coil connection and header.

Figure 8A - Right-hand connection side

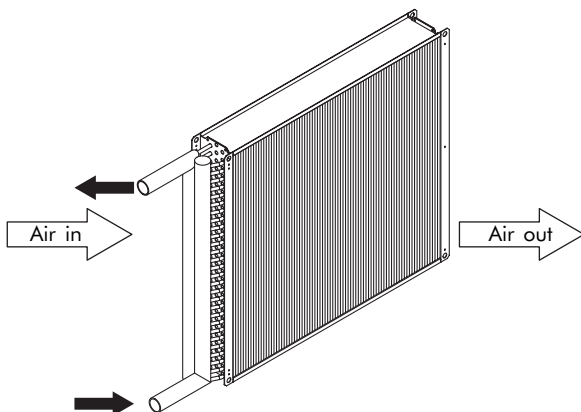
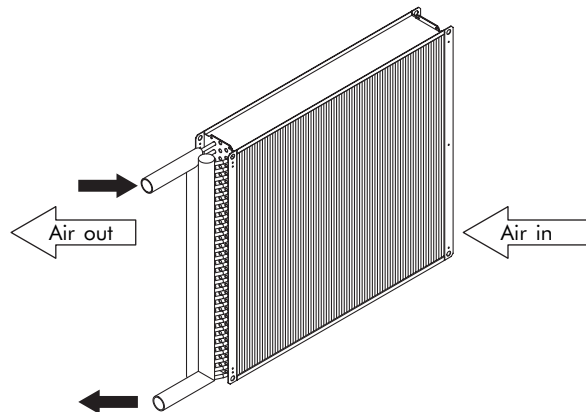

Figure 8B - Left-hand connection side



Condensate drain connection

Drain lines should have the same diameter as that of the drain pan connection.

Drain pan should have traps to permit the condensate from the coils to drain freely.

On both blow-through and draw-through units, the trap depth and the distance between the trap outlet and the drain pan outlet should be twice the static pressure in the drain pan section under normal operation to assure the trap remains sealed (see figure 9).

Figure 9

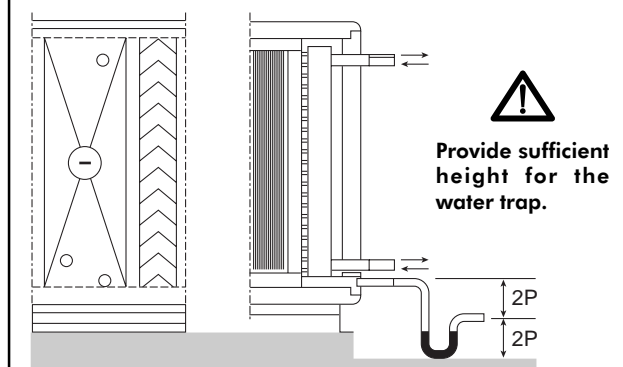

Winterizing water coils

In winter, due to a general shutdown of the installation or a failure of outdoor air damper control, coil freeze-up may occur.

To avoid coil damage, it is recommended to drain completely the non used coils or to fill them with an anti-freeze solution.

The concentration of anti-freeze solution must be regularly and carefully checked before each winter season. It is highly advised to place a heating coil before a cooling coil for an operation during winter season.



Caution

Carefully read instructions for mixing anti-freeze solution used. Some products will have a higher freezing point in its natural state than when mixed with water.

The freezing of coils is not the responsibility of the manufacturer.

7 - Installation (cont'd)

Water volume and connection size of coils

Sizes		20	40	60	90	120	160	200	240	300	360
1 row (+)	Ø Connection Size	26 x 34	26 x 34	26 x 34	26 x 34	26 x 34	26 x 34	26 x 34	26 x 34	33 x 42	33 x 42
	Water volume (l)	1.1	2.1	2.6	3.1	3.7	5.2	6.1	7.0	9.5	11.4
2 rows (+) & (-)	Ø Connection Size	26 x 34	26 x 34	26 x 34	33 x 42	33 x 42	33 x 42	33 x 42	50 x 60	50 x 60	50 x 60
	Water volume (l)	1.6	3.0	4.0	5.7	6.8	9.4	11.3	16.7	20.1	24.0
4 rows (+) & (-)	Ø Connection Size	26 x 34	26 x 34	33 x 42	33 x 42	33 x 42	50 x 60	50 x 60	66 x 76	66 x 76	66 x 76
	Water volume (l)	2.5	4.8	7.5	9.5	11.5	19.7	23.4	31.2	37.4	44.9
6 rows (+) & (-)	Ø Connection Size	26 x 34	33 x 42	33 x 42	50 x 60	50 x 60	66 x 76	66 x 76	66 x 76	80 x 90	80 x 90
	Water volume (l)	3.4	7.2	10.4	15.7	18.9	30.5	36.0	41.4	53.4	64.2
8 rows (-)	Ø Connection Size	33 x 42	40 x 49	40 x 49	50 x 60	50 x 60	66 x 76	66 x 76	80 x 90	80 x 90	80 x 90
	Water volume (l)	4.7	9.7	14.0	19.5	23.5	37.1	44.4	54.7	65.7	79.0

Note : Coils are of **WM type** : 1 to 6-row heating coils (+) and 2 to 8-row cooling coils (-). Fin spacing : **2.1, 2.5 or 3.2** mm. Connection type : **BSP male threaded** for diameter 26 x 34 to 50 x 60, **smooth** for diameter ≥ 66 x 76.

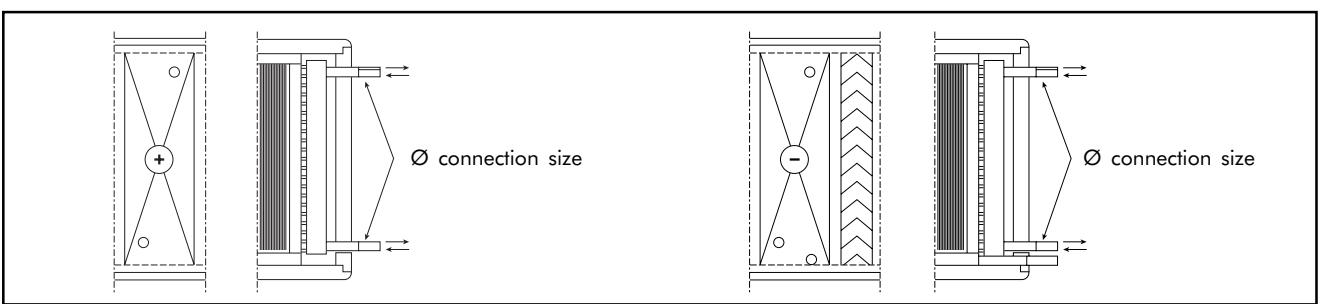

7.5 - Electrical connections

The units are not supplied with electrical panel.

Wiring on the electric motors must be done at site. All motors are designed and produced in accordance with the standards in use.

The connection of these motors will be done according to the indications affixed on the nameplate and on the diagram located in the terminal box.

All motors are equipped, as standard, with a normally closed internal overload protection sensor. This safety device shall be imperatively

connected to the control circuit of the motor. The non-respect of this instruction will cancel compulsorily the warranty on the motor.

Electrical panels must not be mounted on doors or panels providing access to interior of the unit.

Power supply cables entering into the unit, must be run through cable glands mounted on unit panel.

All orifices for cable entry done on the panels must be sealed to prevent leakage.

Single speed motors (1)

<p>Dual-voltage motors with Y / Δ connections</p> <ul style="list-style-type: none"> - Voltage : U - Connection : Δ (at lower marked voltage) - E.G. : 230 V / Δ <ul style="list-style-type: none"> - Voltage : $U \sqrt{3}$ - Connection : Y (at lower marked voltage) - E.G. : 400 V / Y 	<p>Skeleton diagrams</p>	<p>External connection diagrams</p> <p>D.O.L. starting Y / Δ starting</p>
---	---------------------------------	---

(1) Diagrams valid for :

- 3-phase 230 Δ / 400 Y V motors with power from 0.25 to 4.5 kW at 1500 rpm and from 0.25 to 5.5 kW at 3000 rpm,
- 3-phase 400 Δ V motors with power higher or equal to 5.5 kW at 1500 rpm, using Y / Δ starter.

7 - Installation (cont'd)

2-speed motors (2)

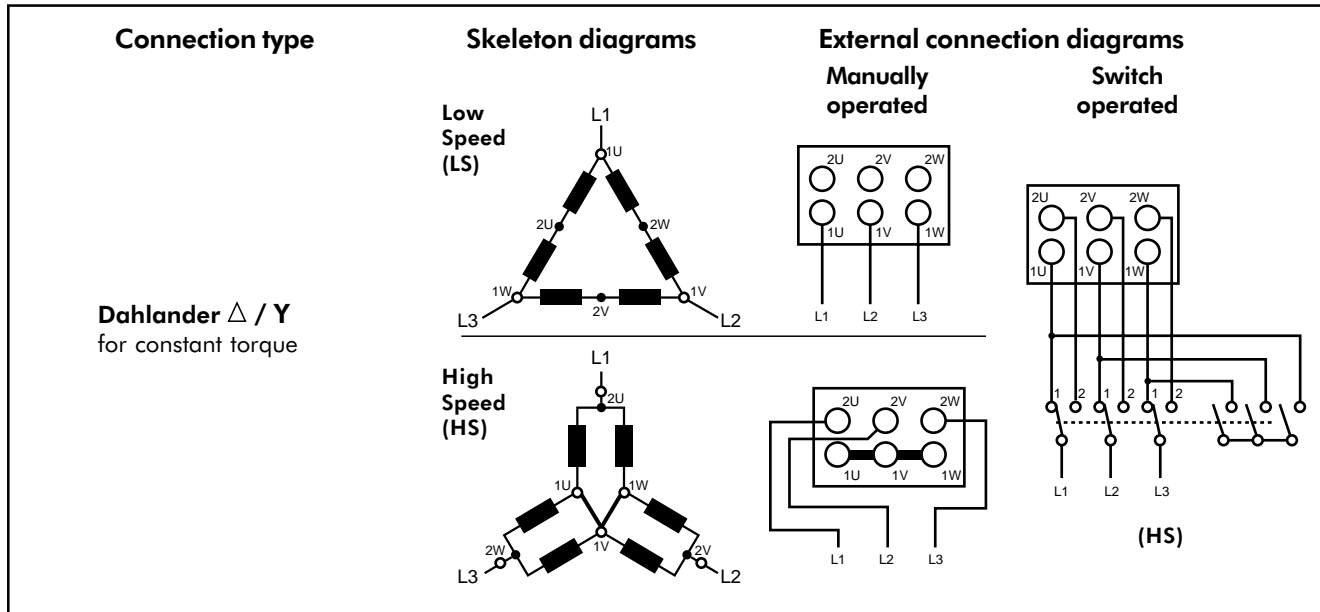

(2) Diagrams valid for 3-phase 400 V at 1500 / 750 rpm and 3000 / 1500 rpm.

2-speed motors (3)

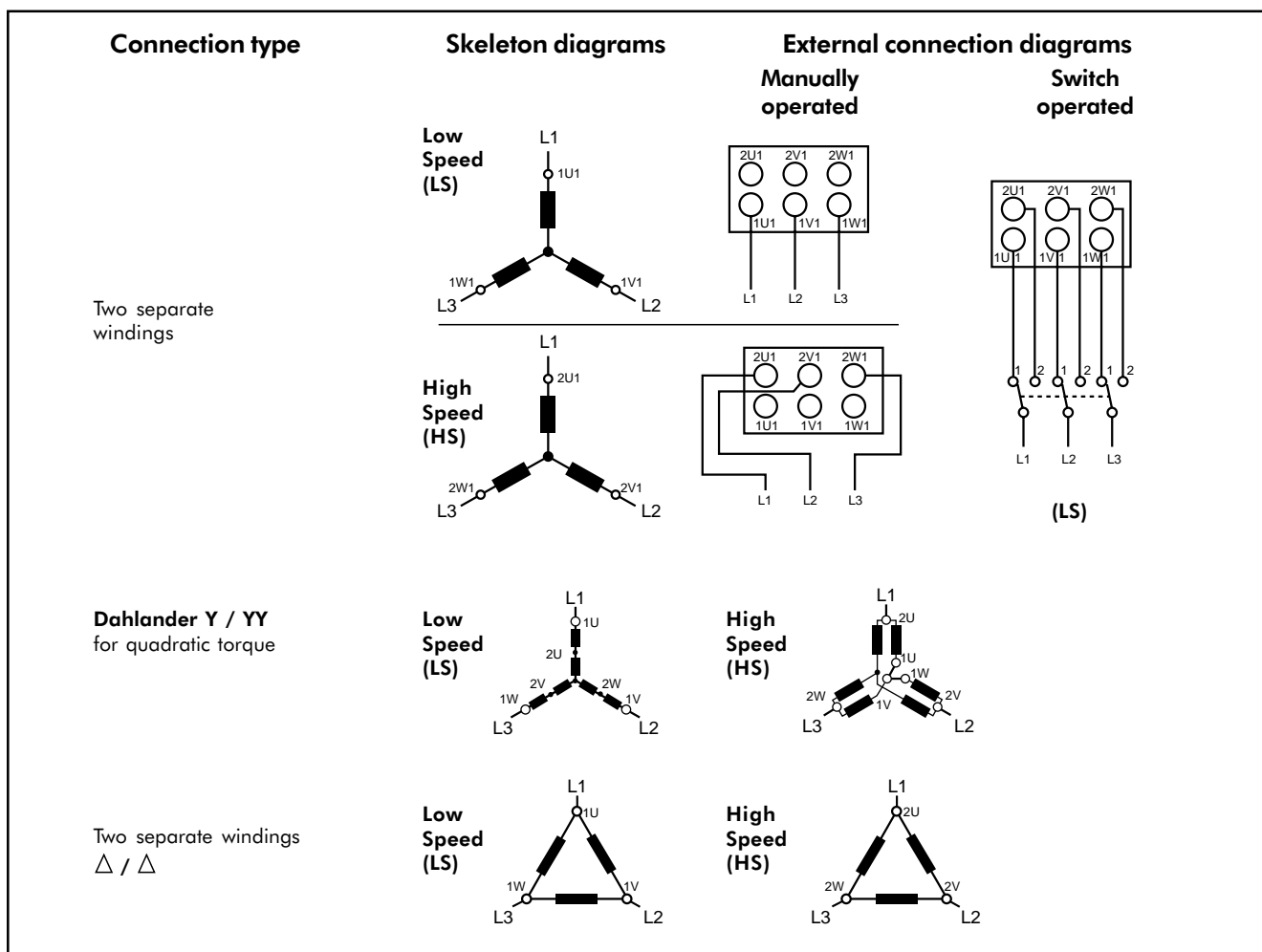

(3) Diagrams valid for 3-phase 400 V at 1500 / 1000 rpm.

8 - Before Startup Checks

When performing startup and service, thorough safety precautions should always be taken.

Only qualified individuals should perform these functions.

1. Check that the unit is completely and properly installed with ductwork connected and that the protective plastic film has been removed.
2. Check that all construction debris are removed and filters are clean.
3. Check that the electrical work is complete and properly terminated.
4. Check that the electrical connections are tight and that the proper voltage is connected.
5. Check that all holes for cable entry are tightly sealed.
6. Check tightness of setscrews on motors, bearings and fans.
7. Check alignment of fan and motor pulleys and belt tension (see drawings below).
8. Check that coil and drain pan connections are properly done.
9. Leak test thermal system to insure that connections are tight.
10. Check that condensate drain is trapped.
11. Check that fans rotate freely.

Belt alignment

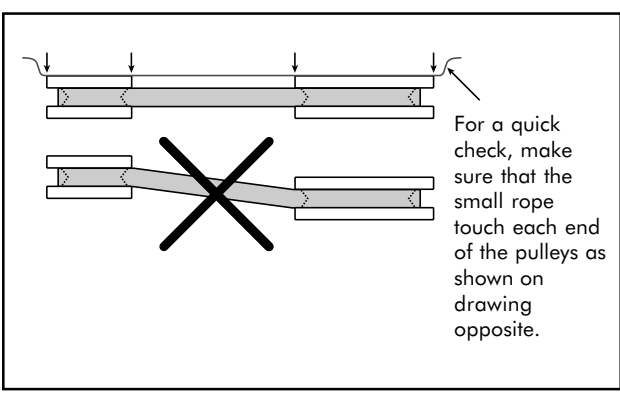

Belt tensioning

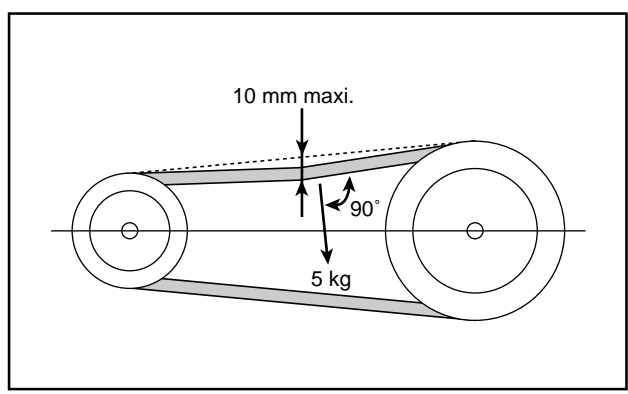

Transport wedges

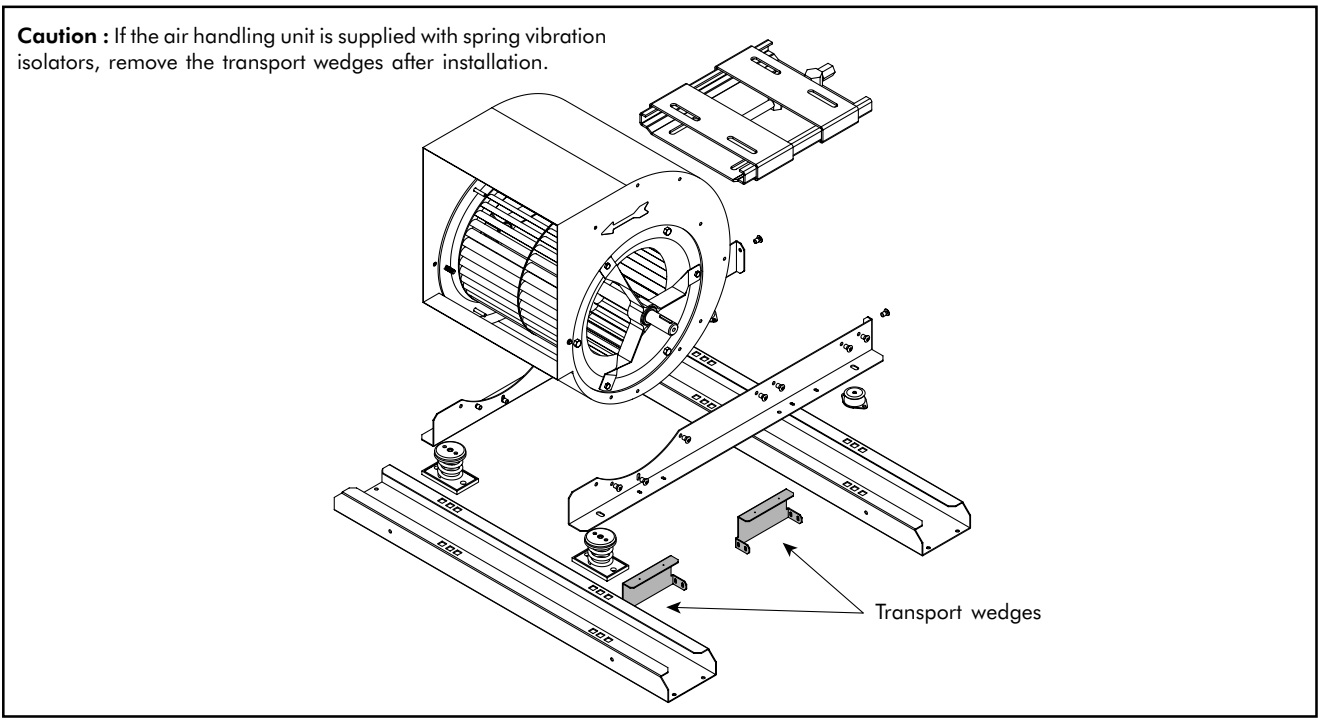

9 - Fan Startup



Caution

Before entering any fan section, make sure the electrical power source to the fan motor is disconnected and locked.

Fan should start and run.

Observe the rotation and if it is not correct, reverse two cables of the 3-phase motor power supply.

Safety precautions

The standard units are not equipped with belt guard.

The access doors must not be opened while the unit is running to avoid the hazard of moving machinery and strong suction forces tending to keep the doors in a closed position.

After first 48 hours of operation

1. Disconnect and lock electrical power source. Check the tightness of bearings, wheel and sheave setscrews (or capscrews).
2. Re-check belt tension, adjust if necessary. Belts tensioned sufficiently to slip one to two seconds at startup will perform satisfactorily extending life and reducing vibrations. If re-tensioning is necessary, be certain pulley sheave alignment is retained.

Unit storage

If air handling units are to be stored for any period of time, it is important to periodically rotate the fan wheel. The fan wheel needs to be rotated to prevent any deflection in the fan shaft which could cause unbalanced fan operation. Also it is important to keep the fan bearings lubricated. If the fan wheel is not periodically rotated, grease will settle in the lower part of the bearing. This can lead to oxidation on the upper portion of the bearing surface which can cause bearing failure.

10 - Maintenance

The user of the air handling units is responsible for the maintenance of the equipments to keep them in good condition of operation.

1. Electrical supply to the fan motor must correspond to the rated voltage on the motor nameplate and be in conformity with the National Electrical Code and local restrictions.
2. Earth wiring to the unit metal structure must be regularly checked.
3. Motor thermal relays and electrical contacts must be regularly checked.
4. Check all moving parts for wear every six months. Check setscrews of motors, fans and bearings for tightness every six months.
5. Filters must be clean to obtain maximum efficiency. They should be inspected periodically and be replaced if necessary. Units should never be operating without filters.
6. Due to the fact that drain pans in any air conditioning unit will have some moisture in them, algae, etc., will grow due to airborne spores and bacteria.

Periodic cleaning is necessary to prevent this build-up from plugging the drain and causing the drain pan to overflow. Also, the drain pans should be kept clean to prevent the spread of disease. Cleaning should be performed by qualified personnel.
7. The condensate drain pan can pick up lint and dirt, especially with dirty filters. Inspect twice a year to avoid the possibility of overflow.

8. Coils must be clean to obtain the maximum performance. Check once a year under normal operating conditions and, if dirty, brush or vacuum clean. Care must be taken not to damage the fins while cleaning.



Caution

Fin edges are sharp and can cause injury hazard. Avoid contact with them.

Fan bearings

All fan bearings are pre-lubricated and do not require addition of grease at time of installation.

The bearings of fan types L and R are long life self-lubricated type, those of the fan types K, K1 and K2 require a yearly periodic inspection with cleaning and renewal of grease if necessary.

A lack or an excess of grease is prejudicial to the bearing and reduces significantly its lifetime.

Air filters

Air filters must be used inside the units.

The cleaning of these filters must be regularly performed according to the utilization or be replaced if necessary.

The tables below show the dimensions and the quantities of the filters to be used for each unit.

10 - Maintenance (cont'd)

Metal flat filters (G2)

Unit sizes	20	40	60	90	120	160	200	240	300	360
287 x 592 (12" x 24")	1		1		2		2		3	
592 x 592 (24" x 24")		1	1	2	2	4	4	6	6	9
Qair max (m ³ /h)	2000	4000	6000	8000	12000	16000	20000	24000	30000	36000
Final Δ P (Pa)	250	250	250	250	250	250	250	250	250	250

Synthetic flat filters (G4)

Unit sizes	20	40	60	90	120	160	200	240	300	360
287 x 592 (12" x 24")	1		1		2		2		3	
592 x 592 (24" x 24")		1	1	2	2	4	4	6	6	9
Qair max (m ³ /h)	2400	4800	7200	9600	14400	19200	24000	28800	36000	43200
Final Δ P (Pa)	250	250	250	250	250	250	250	250	250	250

Long bag filters (F7)

Unit sizes	20	40	60	90	120	160	200	240	300	360
287 x 592 (12" x 24")	1		1		2		2		3	
592 x 592 (24" x 24")		1	1	2	2	4	4	6	6	9
Qair max (m ³ /h)	2261	4522	6783	9044	13566	18088	22610	27132	33915	40698
Final Δ P (Pa)	450	450	450	450	450	450	450	450	450	450

Long bag filters (F8)

Unit sizes	20	40	60	90	120	160	200	240	300	360
287 x 592 (12" x 24")	1		1		2		2		3	
592 x 592 (24" x 24")		1	1	2	2	4	4	6	6	9
Qair max (m ³ /h)	2261	4522	6783	9044	13566	18088	22610	27132	33915	40698
Final Δ P (Pa)	450	450	450	450	450	450	450	450	450	450

Compact filters (F8)

Unit sizes	20	40	60	90	120	160	200	240	300	360
287 x 592 (12" x 24")	1		1		2		2		3	
592 x 592 (24" x 24")		1	1	2	2	4	4	6	6	9
Qair max (m ³ /h)	2261	4522	6783	9044	13566	18088	22610	27132	33915	40698
Final Δ P (Pa)	450	450	450	450	450	450	450	450	450	450

Compact filters (F9)

Unit sizes	20	40	60	90	120	160	200	240	300	360
287 x 592 (12" x 24")	1		1		2		2		3	
592 x 592 (24" x 24")		1	1	2	2	4	4	6	6	9
Qair max (m ³ /h)	2500	5000	7500	10000	15000	20000	25000	30000	37500	45000
Final Δ P (Pa)	600	600	600	600	600	600	600	600	600	600

HEPA filters (H10)

Unit sizes	20	40	60	90	120	160	200	240	300	360
287 x 592 (12" x 24")	1		1		2		2		3	
592 x 592 (24" x 24")		1	1	2	2	4	4	6	6	9
Qair max (m ³ /h)	1500	4000	5500	8000	11000	16000	19000	24000	28500	36000
Final Δ P (Pa)	750	750	750	750	750	750	750	750	750	750

HEPA filters (H13)

Unit sizes	20	40	60	90	120	160	200	240	300	360
287 x 592 (12" x 24")	1		1		2		2		3	
592 x 592 (24" x 24")		1	1	2	2	4	4	6	6	9
Qair max (m ³ /h)	1500	4000	5500	8000	11000	16000	19000	24000	28500	36000
Final Δ P (Pa)	750	750	750	750	750	750	750	750	750	750

Carbon filters (service sector)

Unit sizes	20	40	60	90	120	160	200	240	300	360
287 x 592 (12" x 24")	1		1		2		2		3	
592 x 592 (24" x 24")		1	1	2	2	4	4	6	6	9
Qair max (m ³ /h)	1700	3400	5100	6800	10200	13600	17000	20400	25500	30600
Final Δ P (Pa)	120	120	120	120	120	120	120	120	120	120

Carbon filters (industry)

Unit sizes	20	40	60	90	120	160	200	240	300	360
287 x 592 (12" x 24")	1		1		2		2		3	
592 x 592 (24" x 24")		1	1	2	2	4	4	6	6	9
Qair max (m ³ /h)	1700	3400	5100	6800	10200	13600	17000	20400	25500	30600
Final Δ P (Pa)	150	150	150	150	150	150	150	150	150	150

10 - Maintenance (cont'd)

Quality of water

It is not our policy to make recommendations on water treatment. Contact a local water treatment company regarding this treatment.

However, this topic is critical and care should be taken to make sure it is done properly to obtain effective treatment.

The use of water without treatment can provoke excessive soiling inside water coil tubes with serious repercussions and damages on unit efficiency.

Manufacturer will not be responsible for the use of non-treated water or incorrectly treated one.

11 - Operating Guidelines

Operating limits

1. Do not exceed operating limits indicated in the following tables.

A fan wheel that is operated beyond the rpm and temperature limits may suffer permanent distortion or fracture.

The resulting unbalance may cause severe unit vibration.

2. Vibrations.

Fans have been statically and dynamically balanced at works.

Any running vibration indicates an abnormal working and should be stopped.

Excessive vibration from any cause contributes to premature fan and motor failure.

Overall vibration levels should be monitored every 3 months of operation. An increase in level is an indication of potential trouble.

Vibration causes

1. Wheel imbalance.
 - a. Dirt or debris on wheel blades.
 - b. Loss of the balance weight.
 - c. Wheel distorted due to overspeed or mechanical shock.
2. Bent shaft.
3. Drive failure.
 - a. Drive misalignment.
 - b. Bad belts ; inadequate tension.
4. Faulty bearings, loose hold-down bolts.
5. Motor out of balance.
6. Faulty fan suspension.
7. Inadequate unit vibration isolators.
8. Surging : result of bad calculation of pressure drops at fan discharge.

11 - Operating Guidelines (cont'd)

Operating limits - Standard forward curved fans

Unit sizes	Fan wheel sizes			Max. speed (rpm)	Max. motor power (kW)
	Std	Option 1	Option 2		
PR 20	ADH 160 L			4200	3
		ADH 180 L		4000	3
			ADH 200 L	3800	4
PR 40	ADH 200 L			3800	4
		ADH 225 L		3400	4
			ADH 250 L	2800	4
PR 60	ADH 250 L			2800	4
		ADH 280 L		2500	5.5
			ADH 315 L	2100	5.5
PR 90	ADH 280 L			2500	5.5
		ADH 315 L		2100	5.5
			ADH 355 L	1800	7.5
PR 120	ADH 355 L			1800	7.5
		ADH 400 L		1600	7.5
			ADH 450 L	1400	11
PR 160	ADH 400 L			1600	7.5
		ADH 450 L		1400	11
			ADH 500 L	1200	11
PR 200	ADH 450 L			1400	11
		ADH 500 L		1200	11
			ADH 560 L	1100	15
PR 240	ADH 500 L			1200	11
		ADH 560 L		1100	15
			ADH 630 R	900	15
PR 300	ADH 560 L			1100	15
		ADH 630 R		900	15
			ADH 710 K	850	22
PR 360	ADH 630 R			900	15
		ADH 710 K		850	22
			ADH 800 K	750	22

11 - Operating Guidelines (cont'd)

Operating limits - Standard backward curved fans

Unit sizes	Fan wheel sizes			Max. speed (rpm)	Max. motor power (kW)
	Std	Option 1	Option 2		
PR 20	RDH 180 L			6800	2,2
		RDH 200 L		6000	3
			-	-	-
PR 40	RDH 200 L			6000	3
		RDH 225 L		5800	4
			RDH 250 L	4600	4
PR 60	RDH 250 L			4600	4
		RDH 280 L		4000	5,5
			RDH 315 L	3500	5,5
PR 90	RDH 280 L			4000	5,5
		RDH 315 L		3500	5,5
			RDH 355 L	3300	7,5
PR 120	RDH 355 L			3300	7,5
		RDH 400 L		2700	7,5
			RDH 450 L	2500	11
PR 160	RDH 400 L			2700	7,5
		RDH 450 L		2500	11
			RDH 500 L	2100	11
PR 200	RDH 450 L			2500	11
		RDH 500 L		2100	11
			RDH 560 L	1950	15
PR 240	RDH 500 L			2100	11
		RDH 560 L		1950	15
			RDH 630 R	1600	15
PR 300	RDH 560 L			1950	15
		RDH 630 R		1600	15
			RDH 710 K	1500	22
PR 360	RDH 630 R			1600	15
		RDH 710 K		1500	22
			RDH 800 K	1200	22

11 - Operating Guidelines (cont'd)

Operating limits - Reinforced backward curved fans

Unit sizes	Fan wheel sizes			Max. speed (rpm)	Max. motor power (kW)
	Std	Option 1	Option 2		
PR 20	-	-	-	-	-
	-	-	-	-	-
PR 40	-	-	-	-	-
	-	-	-	-	-
PR 60	-	-	-	-	-
	-	-	-	-	-
PR 90	-	-	-	-	-
	-	-	-	-	-
PR 120	RDH 400 K1	-	-	3500	22
	-	RDH 450 K1	-	3200	30
	-	-	-	-	-
PR 160	RDH 400 K1	-	-	3500	22
	-	RDH 450 K1	-	3200	30
	-	-	RDH 500 K2	2800	37
PR 200	RDH 450 K1	-	-	3200	30
	-	RDH 500 K2	-	2800	37
	-	-	RDH 560 K2	2600	37
PR 240	RDH 500 K2	-	-	2800	37
	-	RDH 560 K2	-	2600	37
	-	-	RDH 630 K2	2300	45
PR 300	RDH 560 K2	-	-	2600	37
	-	RDH 630 K2	-	2300	45
	-	-	RDH 710 K2	2000	55
PR 360	RDH 630 K2	-	-	2300	45
	-	RDH 710 K2	-	2000	55
	-	-	RDH 800 K2	1650	55

Operating limits - Pressure

Type of unit	Maximum negative pressure	Maximum positive pressure
Low and medium pressure units	1500 Pa	1500 Pa

Operating limits - Temperature

Application	Maximum air temperature
Electric motors *	60 °C
Structure	80 °C

* For temperatures between 40 and 60 °C, the motors must be undersized.

Temperature range	Continuous operation	12 hours per day operation
up to 60 °C up to 80 °C	6 months 3 months	1 year 6 months

Wesper[®]

CE

*As part of our ongoing product improvement programme, our products are subject to change without prior notice. Non contractual photos.
Dans un souci d'amélioration constante, nos produits peuvent être modifiés sans préavis. Photos non contractuelles.*

Wesper S.A.

42 cours Jean Jaurès

17800 Pons

France

☎ : +33-5 46 92 33 33

☎ : +33-5 46 91 38 33 - +33-5 46 91 26 44 (Export Department)

www.wesper.com

